

LINEAR MOTORS P10-70X160U



- ✓ 3 x 400VAC Technology
- ✓ Peak forces up to 1120 N
- ✓ Extremely high dynamic
- ✓ Separate connector for sensor and power cable
- ✓ Can also be controlled by standard third-party servo drives

LINEAR MOTORS P10-70x160U

Technical Data **529**

Motor Specifications

P10-70x160U/90 **535**

P10-70x160U/190 **536**

P10-70x160U/290 **537**

P10-70x160U/390 **538**

P10-70x160U/490 **539**

P10-70x160U/590 **540**

P10-70x160U/690 **541**

P10-70x160U/890 **542**

P10-70x160U/1090 **543**

P10-70x160U/1290 **544**

P10-70x160U/1490 **545**

P10-70x160U/1690 **546**

Linear Guides **547**

Accessories **549**



MOTOR FAMILY P10-70x160U

Technical Data				
Stroke				
Max. Stroke (ES)	mm (in)		1690 (66.49)	
Force				
Max. Force ¹ @ 1x230VAC	N (lbf)		1120 (252)	
Max. Force ¹ @ 3x400VAC	N (lbf)		1120 (252)	
Max. Cont. Force [Passive cooling / Fan / Fluid]	N (lbf)		130 / 200 / 350 (29 / 45 / 79)	
Max. Border Force relative	%		100	
Force Constant 1	N/A _{pk} (lbf/A _{pk})		56 (12.6)	
Force Constant 2	N/A _{rms} (lbf/A _{rms})		79.2 (17.8)	
Velocity				
Max. Velocity @ 1x230VAC	m/s (in/s)		3.2 (129.9)	
Max. Velocity @ 3x400VAC	m/s (in/s)		5.6 (219.9)	
Position Detection				
Position Resolution	mm (in)		0.005 (0.0002)	
Repeatability	mm (in)		±0.05 (±0.002)	
Position Resolution with ES	mm (in)		0.001 (0.00004)	
Repeatability with ES	mm (in)		±0.01 (±0.0004)	
Linearity with ES	mm (in)		±0.01 (±0.0004)	
Electrical Data				
Max. Current ¹ @ 1x230VAC	A _{pk} / A _{rms}		19.9 / 14	
Max. Current ¹ @ 3x400VAC	A _{pk} / A _{rms}		19.9 / 14	
Max. Cont. Current 1 [Passive cooling / Fan / Fluid]	A _{pk}		2.3 / 3.6 / 6.3	
Max. Cont. Current 2 [Passive cooling / Fan / Fluid]	A _{rms}		1.7 / 2.5 / 4.4	
Back EMF Constant	V _{pk} / (m/s) (V _{pk} / (in/s))		64.7 (1.64)	
Terminal Resistance 25 °C / 120 °C	Ohm		8.3 / 11	
Terminal Inductivity	mH		16	
Magnetic Period	mm (in)		40 (1.57)	
Thermal Data				
Max. Winding Temperature (Sensor)	°C		90	
Thermal Resistance [Passive cooling / Fan / Fluid]	°K/W		1.3 / 0.56 / 0.18	
Thermal Time Constant [Passive cooling / Fan / Fluid]	s		2100 / 500 / 110	
Mechanical Data				
Stator Diameter	mm (in)		70 (2.8)	
Stator Length	mm (in)		260 (10)	
Stator Mass	g (lb)		4200 (9.24)	
Slider Diameter	mm (in)		28 (1.1)	
Slider Length	mm (in)		390 - 1990 (15 - 78)	
Slider Mass	g (lb)		1830 - 9350 (4.03 - 20.57)	
IP Code			IP 65	
Certification				
UL	File-No.		E354430	

1) Real time calculation of motor winding temperature is required (including monitoring).
If temperature monitoring is only based on temperature sensor signal (missing thermal model calculation), 60 % of the peak value has to be taken instead.

STATOR

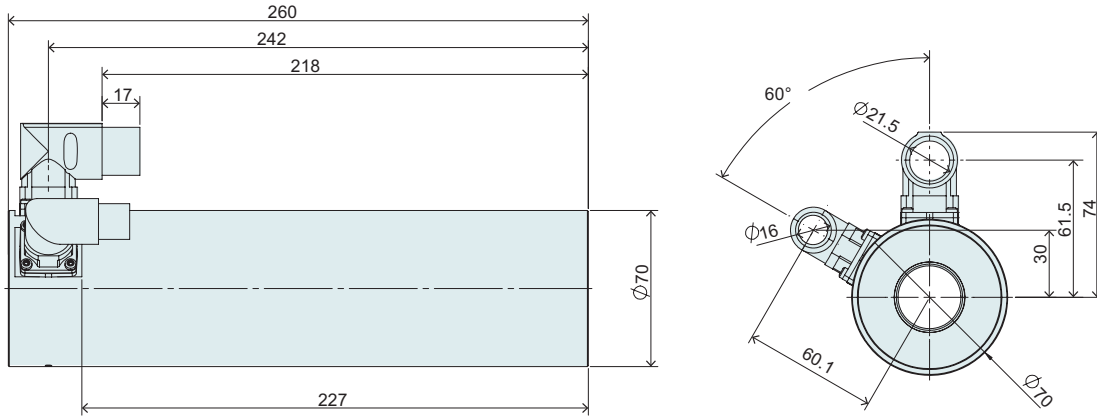

Item	Description	Item-No.	Comment
PS10-70x160U-BL-QJ	Stator 3x400VAC, LinMot Encoder	0150-1292	For use with LinMot Drives
PS10-70x160U-BL-QJ-D01	Stator 3x400VAC, Sin/Cos Encoder 1Vpp, KTY	0150-2283	For use with 3rd Party Drives
PS10-70x160U-BL-QJ-D02	Stator 3x400VAC, Sin/Cos Encoder 1Vpp, PTC	0150-2361	For use with 3rd Party Drives
PS10-70x160U-BL-QJ-D03	Stator 3x400VAC, Sin/Cos 1Vpp, KTY on power connector	0150-2709	For use with 3rd Party Drives

CONNECTOR PS10-70x160U-BL-QJ (INTERFACE FOR LINMOT DRIVES)

Motor Connector Wiring		Connector Encoder J	Wire Color Motor Cable
+5VDC*	Supply	1	red
GND	Supply	2	black
Sense +5V*	Supply Sense	3	white
Sense GND*	Supply Sense	4	brown
Mot. Link C+	Communication	5	pink
Mot. Link C-	Communication	6	grey
Sin+	Encoder	7	yellow
Sin-	Encoder	8	orange
Cos+	Encoder	9	green
Cos-	Encoder	10	blue
n. c.	n. c.	11	n. c.
n. c.	n. c.	12	n. c.
n. c.	n. c.	13	n. c.
n. c.	n. c.	14	n. c.
n. c.	n. c.	15	n. c.
n. c.	n. c.	16	n. c.
n. c.	n. c.	17	n. c.

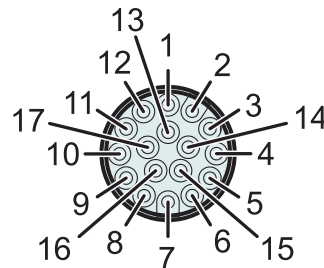

Connector Encoder J

View: Motor connector, plug side

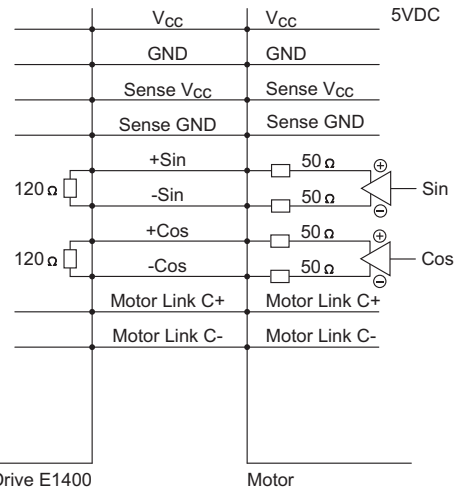

* The supply voltage at 5V sense supply is approx. 6V. Newer motors are provided with a modified power supply, that does not require sense lines any more. In that case, a supply voltage of 6...9V is permitted.

Motor Connector Wiring	Connector Power Q	Wire Color Motor Cable
Phase U	1	red
PE	2	yellow-green
Phase W	3	black (previously: green)
Phase V	4	blue
n. c.	A	n. c.
n. c.	B	n. c.
n. c.	C	n. c.
n. c.	D	n. c.

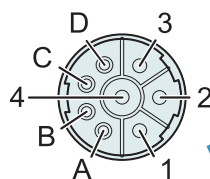

Connector Power Q

View: Motor connector, plug side

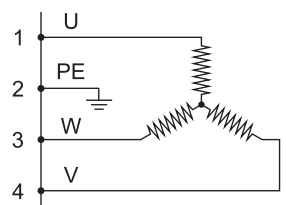

CONNECTOR PS10-70x160U-BL-QJ-D01/02 (INTERFACE FOR 3RD PARTY DRIVES)

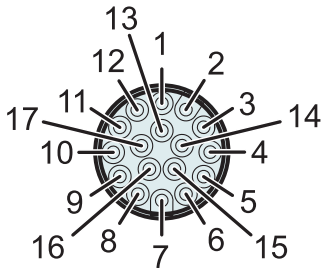

Connector Encoder J

View: Motor connector, plug side

3 ... 13VDC
($I_{max} < 150\text{mA}$ @ 5VDC)
($I_{max} < 80\text{mA}$ @ 12VDC)

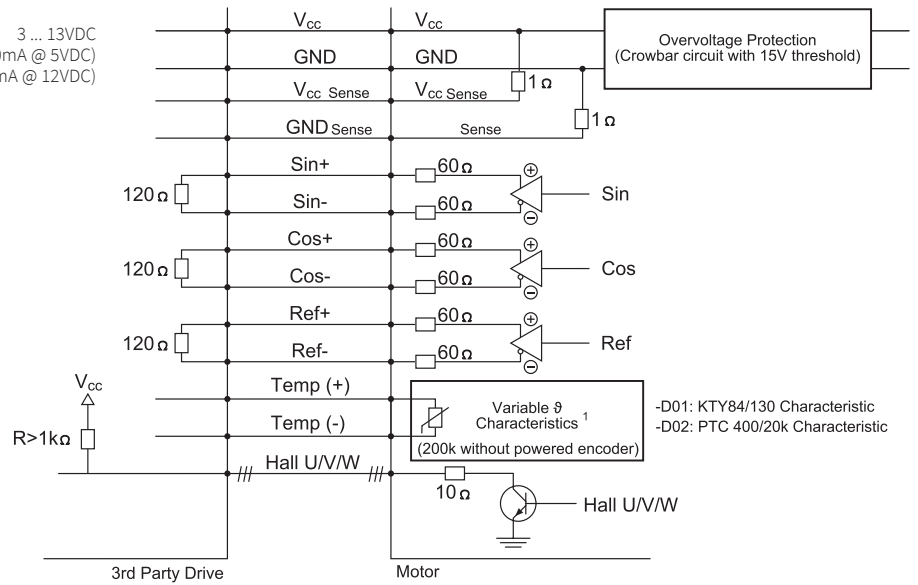

-D01: KTY84/130 Characteristic
-D02: PTC 400/20k Characteristic

Motor Connector Wiring				
PS10-70x160U-BL-QJ-D01	PS10-70x160U-BL-QJ-D02	Function	Connector Encoder J	Wire Color Motor Cable
3 ... 13 VDC	3 ... 13 VDC	Supply	1	white
GND	GND	Supply	2	brown
Vcc Sense (optional)	Vcc Sense (optional)	Supply Sense	3	green
GND Sense (optional)	GND Sense (optional)	Supply Sense	4	yellow
Do not connect	Do not connect	-	5	-
Do not connect	Do not connect	-	6	-
Sin+	Sin+	Encoder 1 Vpp	7	grey
Sin-	Sin-	Encoder 1 Vpp	8	pink
Cos+	Cos+	Encoder 1 Vpp	9	blue
Cos-	Cos-	Encoder 1 Vpp	10	red
Ref+	Ref+	Encoder 1 Vpp	11	black
Ref-	Ref-	Encoder 1 Vpp	12	violett
Hall U	Hall U	Encoder (open collector)	13	grey-red
Hall V	Hall V	Encoder (open collector)	14	red-blue
Hall W	Hall W	Encoder (open collector)	15	white-green
Temp+ (KTY84/130 Char.)	Temp+ (PTC 400/20k Char.)	Temperature ¹	16	yellow-brown
Temp- (KTY84/130 Char.)	Temp- (PTC 400/20k Char.)	Temperature ¹	17	white-yellow

1) The temperature evaluation circuit must be powered from the encoder supply and must be at the same potential. The grounds of the temperature evaluation circuit and the encoder have to be connected. The encoder must have been powered on for at least 50 ms, before valid temperatures can be measured. If the encoder is powered off, 200k Ohms are measured between Pins 16 and 17. The maximum voltage between Pin 16 and 17 must not exceed 16 VDC. The maximum current must not exceed 15 mA.

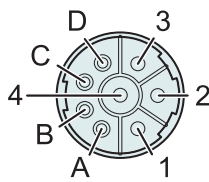

Connector Power Q

View: Motor connector, plug side

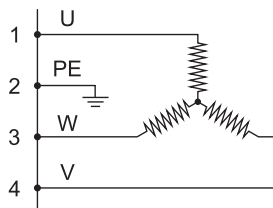

Motor Connector Wiring			
PS10-70x160U-BL-QJ-D01	PS10-70x160U-BL-QJ-D02	Connector Power Q	Wire Color Motor Cable
Phase U	Phase U	1	red
PE	PE	2	yellow-green
Phase W	Phase W	3	black (previously: green)
Phase V	Phase V	4	blue
n. c.	n. c.	A	n. c.
n. c.	n. c.	B	n. c.
n. c.	n. c.	C	n. c.
n. c.	n. c.	D	n. c.

CONNECTOR PS10-70x160U-BL-QJ-D03 (INTERFACE FOR 3RD PARTY DRIVES)

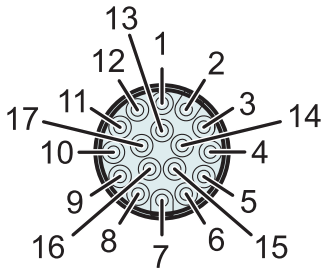

Connector Encoder J

View: Motor connector, plug side

3 ... 13VDC
($I_{max} < 150\text{mA}$ @ 5VDC)
($I_{max} < 80\text{mA}$ @ 12VDC)

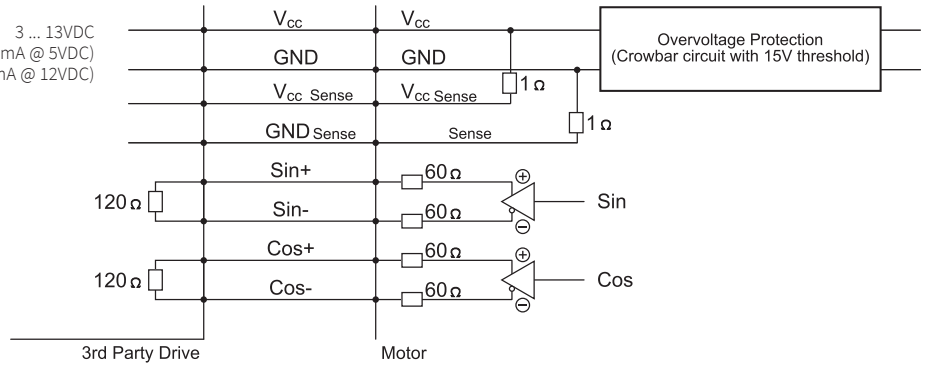

Motor Connector Wiring		Connector Encoder J	Wire Color Motor Cable
3 ... 13 VDC	Supply	1	red
GND	Supply	2	black
Vcc Sense (optional)	Supply Sense	3	white
GND Sense (optional)	Supply Sense	4	brown
Do not connect	-	5	-
Do not connect	-	6	-
Sin+	Encoder 1 Vpp	7	yellow
Sin-	Encoder 1 Vpp	8	orange
Cos+	Encoder 1 Vpp	9	green
Cos-	Encoder 1 Vpp	10	blue
n. c.	-	11	n. c.
n. c.	-	12	n. c.
n. c.	-	13	n. c.
Do not connect	-	14	n. c.
n. c.	-	15	n. c.
n. c.	-	16	n. c.
n. c.	-	17	n. c.

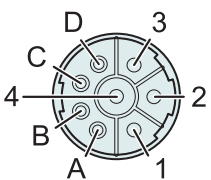

Connector Power Q

View: Motor connector, plug side

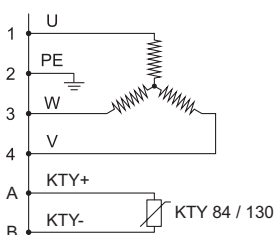

Motor Connector Wiring	Connector Power Q	Wire Color Motor Cable Variant colored (new)	Wire Color Motor Cable Variant black
Phase U	1	red	black 1
PE	2	yellow-green	yellow-green
Phase W	3	black (previously: green)	black 3
Phase V	4	blue	black 2
KTY +	A	purple	black 5
KTY -	B	grey	black 6
n. c.	C	yellow	black 7
n. c.	D	brown	black 8

DOX POSITION FEEDBACK (SIN / COS INTERFACE FOR 3RD PARTY DRIVES)

The Linear Motor Series P10-70 has noncontact, integral position feedback. No external encoder is required. Position output is industry standard 1Vpp sin/cos signals with 40mm period. The position sensor outputs analogue, differential sine and cosine signals to provide position feedback. The relation between the phase current and the position sensor output is shown on the right. (SIN+ and SIN- encoder signal is always in phase with motor current phase U).

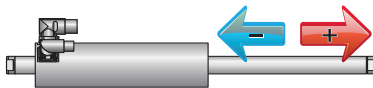

The arrows indicate the direction of movement of the slider. The stator is locked into position.

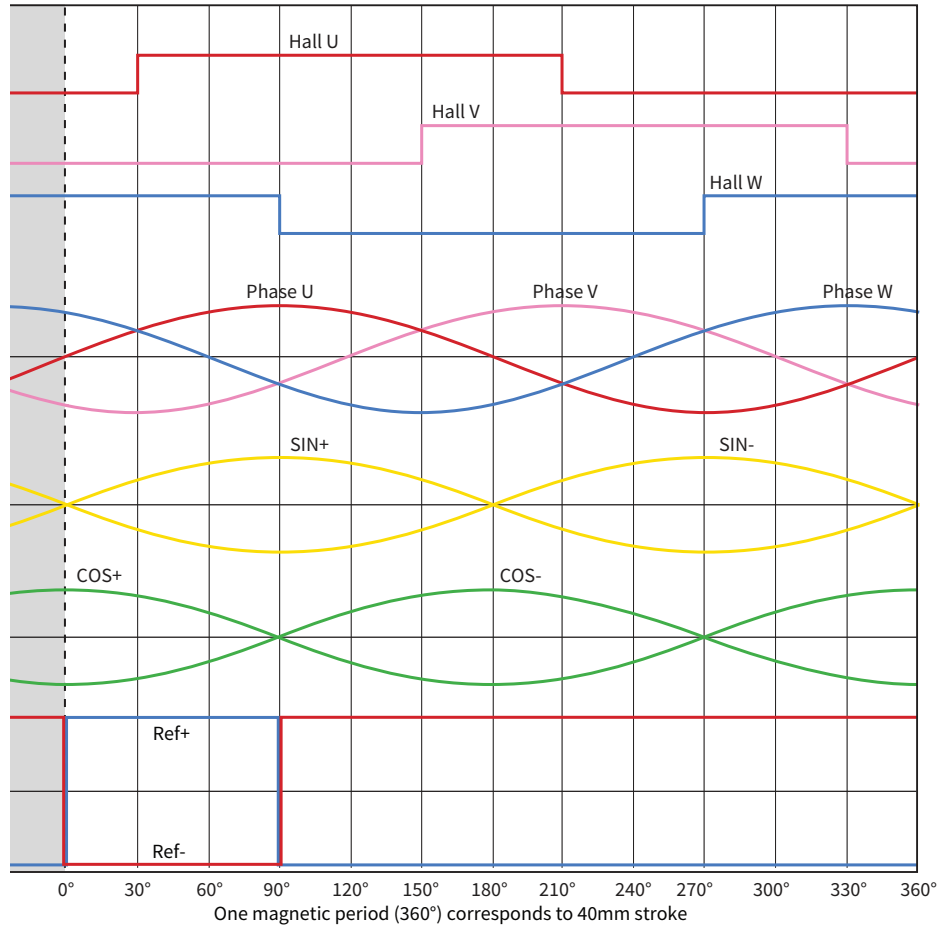

		P10-70x...-D0x
Output signal period	mm	40
Signal amplitude ³	V _{pp}	1
Termination ³	Ohm	120
Supply voltage	V _d c	3...13 (w or w/o sense)
Power consumption	mW	< 1000
		(I < 150mA @ 5VDC, I < 80mA @ 12 VDC) ²
Position repeatability ¹	µm	±20
Linearity over 1m ¹	%	< ±0.025

1) Dependent on the amplifier. Under constant operating and thermal conditions.
 2) Power efficiency of the motor electronics varies with supply voltage
 3) Applicable for sin+/sin-, cos+/cos- and ref+/ref- signals. Hall U/V/W are open collector signals.

DOX TEMPERATURE FEEDBACK (SIN / COS INTERFACE FOR 3RD PARTY DRIVES)

D01 / D02

Overheat protection is provided by three internal thermistors embedded in the motor windings. These thermistors are monitored by the motor's electronics. A single thermistor is emulated based on the maximum of the measured temperature values. This is done to accurately monitor the temperature over the whole length of the stator and to react as fast as possible to dynamic changes in a single motor phase. As the motor winding temperature reaches its absolute maximum value, the drive amplifier or servo control-

ler must disable the motor in order to protect the motor from overheat damages.

D03

Overheat protection is provided by a single internal temperature sensor embedded in the middle of the motor windings. As the motor winding temperature reaches its absolute maximum value, the drive amplifier or servo controller must disable the motor in order to protect the motor from overheat damages.



Attention: It is strongly recommended that the motor over-temperature sensor is connected to the drive amplifier or servo controller at all times in order to reduce the risk of damage to the motor due to excessive temperatures. For D01 and D02 motors, the motor encoder has to be powered to ensure correct temperature read-outs.

SLIDER

Slider Standard

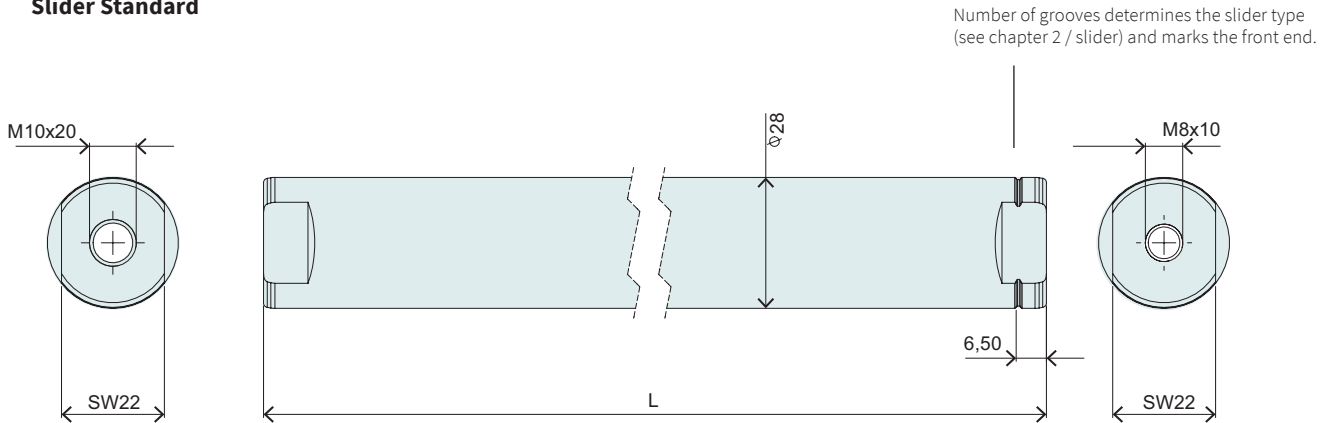

Slider Standard			
Item	Description	Max. Stroke [mm]	Item-No.
PL10-28x390/340	Slider for P10-70 'standard'	70	0150-2194
PL10-28x490/440	Slider for P10-70 'standard'	170	0150-2195
PL10-28x590/540	Slider for P10-70 'standard'	270	0150-2196
PL10-28x690/640	Slider for P10-70 'standard'	370	0150-2197
PL10-28x790/740	Slider for P10-70 'standard'	470	0150-2198
PL10-28x890/840	Slider for P10-70 'standard'	570	0150-2199
PL10-28x990/940	Slider for P10-70 'standard'	670	0150-2203
PL10-28x1190/1140	Slider for P10-70 'standard'	770	0150-2204
PL10-28x1390/1340	Slider for P10-70 'standard'	970	0150-2205
PL10-28x1590/1540	Slider for P10-70 'standard'	1170	0150-2206
PL10-28x1790/1740	Slider for P10-70 'standard'	1370	0150-2207
PL10-28x1990/1940	Slider for P10-70 'standard'	1570	0150-2208

P10-70x160U/90-BL-QJ

Max. Stroke: 90 mm
Peak Force: 1120 N

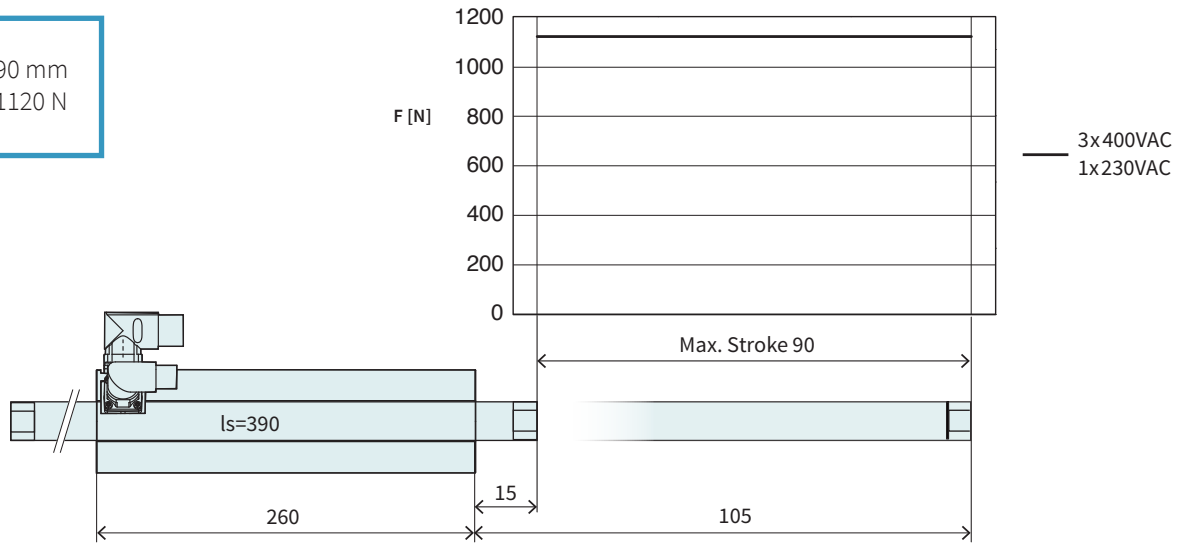

Dimensions in mm

Technical Data P10-70x160U/90

Stroke			
Max. Stroke	mm (in)		90 (3.53)
Force			
Max. Force ¹ @ 1x230VAC	N (lbf)		1120 (252)
Max. Force ¹ @ 3x400VAC	N (lbf)		1120 (252)
Max. Cont. Force [Passive cooling / Fan / Fluid]	N (lbf)		130 / 200 / 350 (29 / 45 / 79)
Max. Border Force relative	%		100
Force Constant 1	N/A _{pk} (lbf/A _{pk})		56 (12.6)
Force Constant 2	N/A _{rms} (lbf/A _{rms})		79.2 (17.8)
Velocity			
Max. Velocity @ 1x230VAC	m/s (in/s)		3.2 (129.9)
Max. Velocity @ 3x400VAC	m/s (in/s)		5.6 (5.6)
Position Detection			
Repeatability	mm (in)		±0.05 (±0.002)
Linearity	%		±0.65
Electrical Data			
Max. Current ¹ @ 1x230VAC	A _{pk} / A _{rms}		19.9 / 14
Max. Current ¹ @ 3x400VAC	A _{pk} / A _{rms}		19.9 / 14
Max. Cont. Current 1 [Passive cooling / Fan / Fluid]	A _{pk}		2.3 / 3.6 / 6.3
Max. Cont. Current 2 [Passive cooling / Fan / Fluid]	A _{rms}		1.7 / 2.5 / 4.4
Thermal Data			
Max. Winding Temperature (Sensor)	°C		90
Thermal Resistance [Passive cooling / Fan / Fluid]	°K/W		1.3 / 0.56 / 0.18
Thermal Time Constant [Passive cooling / Fan / Fluid]	s		2100 / 500 / 110
Mechanical Data			
Slider Length	mm (in)		390 (15)
Slider Mass	g (lb)		1830 (4.03)

1) Real time calculation of motor winding temperature is required (including monitoring).
 If temperature monitoring is only based on temperature sensor signal (missing thermal model calculation), 60 % of the peak value has to be taken instead.



Item	Description	Item-No.
PS10-70x160U-BL-QJ	Stator 3x400VAC, LinMot Encoder	0150-1292
PS10-70x160U-BL-QJ-D01	Stator 3x400VAC, Sin/Cos Encoder 1Vpp, KTY	0150-2283
PS10-70x160U-BL-QJ-D02	Stator 3x400VAC, Sin/Cos Encoder 1Vpp, PTC	0150-2361
PS10-70x160U-BL-QJ-D03	Stator 3x400VAC, Sin/Cos 1Vpp, KTY on power connector	0150-2709
PL10-28x390/340	Slider for P10-70 'standard'	0150-2194

P10-70x160U/190-BL-QJ

Max. Stroke: 190 mm
Peak Force: 1120 N

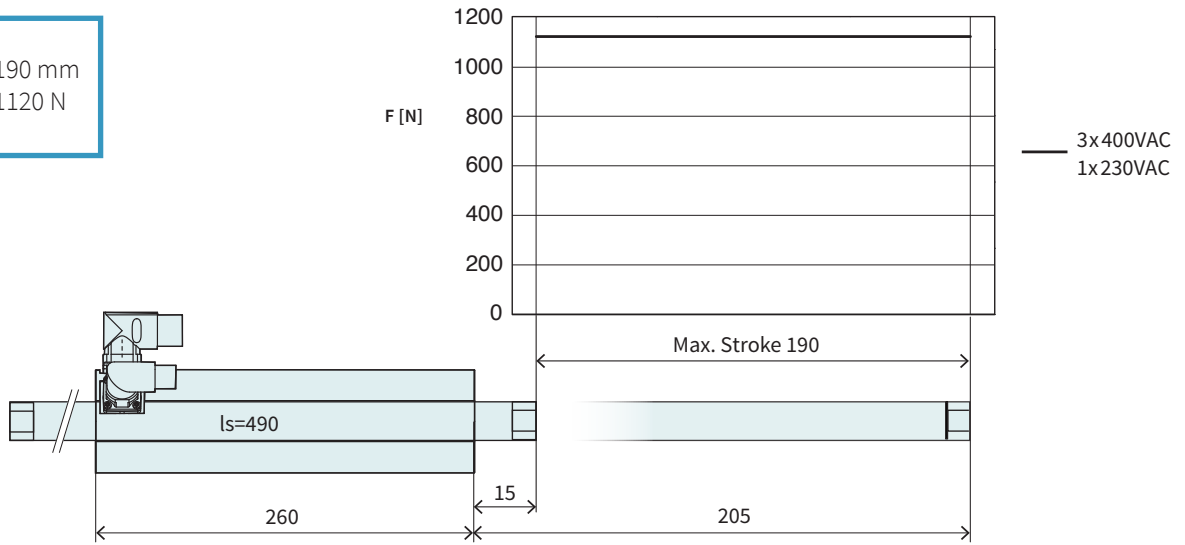

Dimensions in mm

Technical Data P10-70x160U/190

Stroke			
Max. Stroke	mm (in)		190 (7.48)
Force			
Max. Force ¹ @ 1x230VAC	N (lbf)		1120 (252)
Max. Force ¹ @ 3x400VAC	N (lbf)		1120 (252)
Max. Cont. Force [Passive cooling / Fan / Fluid]	N (lbf)		130 / 200 / 350 (29 / 45 / 79)
Max. Border Force relative	%		100
Force Constant 1	N/A _{pk} (lbf/A _{pk})		56 (12.6)
Force Constant 2	N/A _{rms} (lbf/A _{rms})		79.2 (17.8)
Velocity			
Max. Velocity @ 1x230VAC	m/s (in/s)		3.2 (129.9)
Max. Velocity @ 3x400VAC	m/s (in/s)		5.6 (5.6)
Position Detection			
Repeatability	mm (in)		±0.05 (±0.002)
Linearity	%		± 0.35
Electrical Data			
Max. Current ¹ @ 1x230VAC	A _{pk} / A _{rms}		19.9 / 14
Max. Current ¹ @ 3x400VAC	A _{pk} / A _{rms}		19.9 / 14
Max. Cont. Current 1 [Passive cooling / Fan / Fluid]	A _{pk}		2.3 / 3.6 / 6.3
Max. Cont. Current 2 [Passive cooling / Fan / Fluid]	A _{rms}		1.7 / 2.5 / 4.4
Thermal Data			
Max. Winding Temperature (Sensor)	°C		90
Thermal Resistance [Passive cooling / Fan / Fluid]	°K/W		1.3 / 0.56 / 0.18
Thermal Time Constant [Passive cooling / Fan / Fluid]	s		2100 / 500 / 110
Mechanical Data			
Slider Length	mm (in)		490 (19)
Slider Mass	g (lb)		2300 (5.06)

1) Real time calculation of motor winding temperature is required (including monitoring).
 If temperature monitoring is only based on temperature sensor signal (missing thermal model calculation), 60 % of the peak value has to be taken instead.



Item	Description	Item-No.
PS10-70x160U-BL-QJ	Stator 3x400VAC, LinMot Encoder	0150-1292
PS10-70x160U-BL-QJ-D01	Stator 3x400VAC, Sin/Cos Encoder 1Vpp, KTY	0150-2283
PS10-70x160U-BL-QJ-D02	Stator 3x400VAC, Sin/Cos Encoder 1Vpp, PTC	0150-2361
PS10-70x160U-BL-QJ-D03	Stator 3x400VAC, Sin/Cos 1Vpp, KTY on power connector	0150-2709
PL10-28x490/440	Slider for P10-70 'standard'	0150-2195

P10-70x160U/290-BL-QJ

Max. Stroke: 290 mm
Peak Force: 1120 N

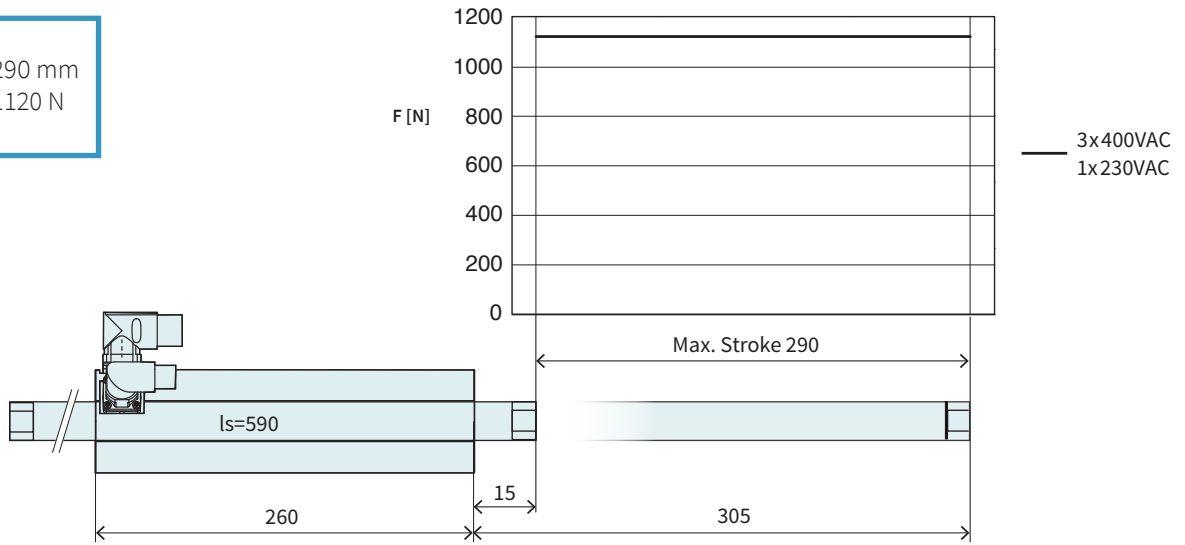

Dimensions in mm

Technical Data P10-70x160U/290			
Stroke			
Max. Stroke	mm (in)		290 (11.4)
Force			
Max. Force ¹ @ 1x230VAC	N (lbf)		1120 (252)
Max. Force ¹ @ 3x400VAC	N (lbf)		1120 (252)
Max. Cont. Force [Passive cooling / Fan / Fluid]	N (lbf)		130 / 200 / 350 (29 / 45 / 79)
Max. Border Force relative	%		100
Force Constant 1	N/A _{pk} (lbf/A _{pk})		56 (12.6)
Force Constant 2	N/A _{rms} (lbf/A _{rms})		79.2 (17.8)
Velocity			
Max. Velocity @ 1x230VAC	m/s (in/s)		3.2 (129.9)
Max. Velocity @ 3x400VAC	m/s (in/s)		5.6 (5.6)
Position Detection			
Repeatability	mm (in)		±0.05 (±0.002)
Linearity	%		± 0.25
Electrical Data			
Max. Current ¹ @ 1x230VAC	A _{pk} / A _{rms}		19.9 / 14
Max. Current ¹ @ 3x400VAC	A _{pk} / A _{rms}		19.9 / 14
Max. Cont. Current 1 [Passive cooling / Fan / Fluid]	A _{pk}		2.3 / 3.6 / 6.3
Max. Cont. Current 2 [Passive cooling / Fan / Fluid]	A _{rms}		1.7 / 2.5 / 4.4
Thermal Data			
Max. Winding Temperature (Sensor)	°C		90
Thermal Resistance [Passive cooling / Fan / Fluid]	°K/W		1.3 / 0.56 / 0.18
Thermal Time Constant [Passive cooling / Fan / Fluid]	s		2100 / 500 / 110
Mechanical Data			
Slider Length	mm (in)		590 (23)
Slider Mass	g (lb)		2770 (6.09)

1) Real time calculation of motor winding temperature is required (including monitoring).
 If temperature monitoring is only based on temperature sensor signal (missing thermal model calculation), 60 % of the peak value has to be taken instead.



Item	Description	Item-No.
PS10-70x160U-BL-QJ	Stator 3x400VAC, LinMot Encoder	0150-1292
PS10-70x160U-BL-QJ-D01	Stator 3x400VAC, Sin/Cos Encoder 1Vpp, KTY	0150-2283
PS10-70x160U-BL-QJ-D02	Stator 3x400VAC, Sin/Cos Encoder 1Vpp, PTC	0150-2361
PS10-70x160U-BL-QJ-D03	Stator 3x400VAC, Sin/Cos 1Vpp, KTY on power connector	0150-2709
PL10-28x590/540	Slider for P10-70 'standard'	0150-2196

P10-70x160U/390-BL-QJ

Max. Stroke: 390 mm
Peak Force: 1120 N

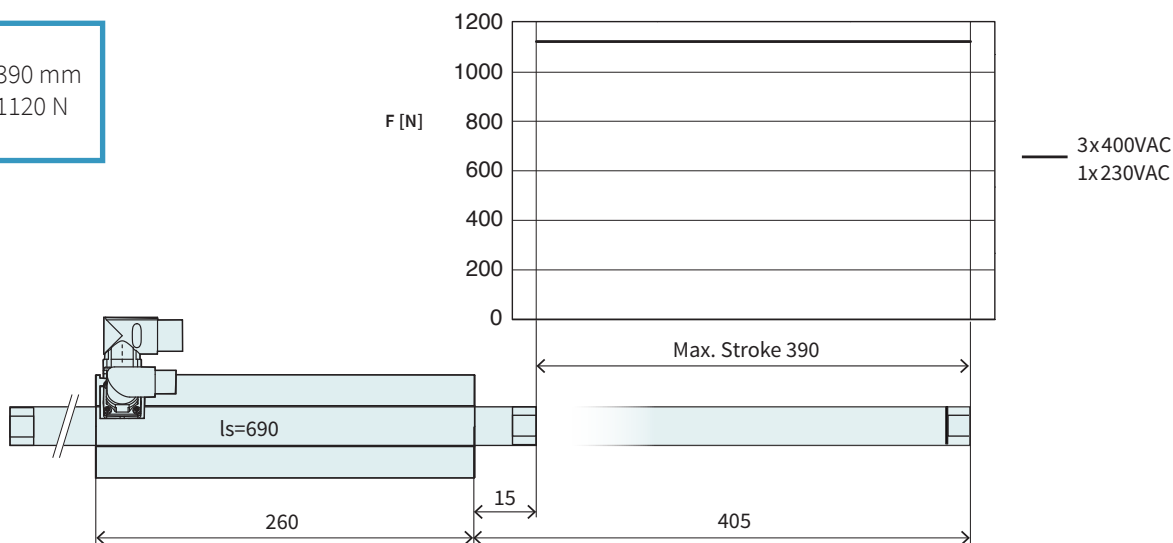

Dimensions in mm

Technical Data P10-70x160U/390

Stroke			
Max. Stroke	mm (in)		390 (15.4)
Force			
Max. Force ¹ @ 1x230VAC	N (lbf)		1120 (252)
Max. Force ¹ @ 3x400VAC	N (lbf)		1120 (252)
Max. Cont. Force [Passive cooling / Fan / Fluid]	N (lbf)		130 / 200 / 350 (29 / 45 / 79)
Max. Border Force relative	%		100
Force Constant 1	N/A _{pk} (lbf/A _{pk})		56 (12.6)
Force Constant 2	N/A _{rms} (lbf/A _{rms})		79.2 (17.8)
Velocity			
Max. Velocity @ 1x230VAC	m/s (in/s)		3.2 (129.9)
Max. Velocity @ 3x400VAC	m/s (in/s)		5.6 (5.6)
Position Detection			
Repeatability	mm (in)		±0.05 (±0.002)
Linearity	%		± 0.25
Electrical Data			
Max. Current ¹ @ 1x230VAC	A _{pk} / A _{rms}		19.9 / 14
Max. Current ¹ @ 3x400VAC	A _{pk} / A _{rms}		19.9 / 14
Max. Cont. Current 1 [Passive cooling / Fan / Fluid]	A _{pk}		2.3 / 3.6 / 6.3
Max. Cont. Current 2 [Passive cooling / Fan / Fluid]	A _{rms}		1.7 / 2.5 / 4.4
Thermal Data			
Max. Winding Temperature (Sensor)	°C		90
Thermal Resistance [Passive cooling / Fan / Fluid]	°K/W		1.3 / 0.56 / 0.18
Thermal Time Constant [Passive cooling / Fan / Fluid]	s		2100 / 500 / 110
Mechanical Data			
Slider Length	mm (in)		690 (27)
Slider Mass	g (lb)		3240 (7.13)

1) Real time calculation of motor winding temperature is required (including monitoring).
 If temperature monitoring is only based on temperature sensor signal (missing thermal model calculation), 60 % of the peak value has to be taken instead.

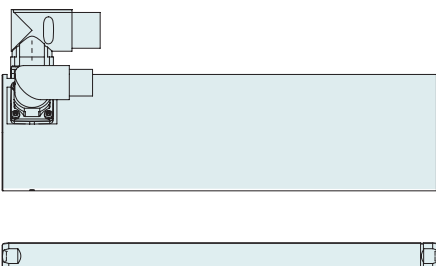

Item	Description	Item-No.
PS10-70x160U-BL-QJ	Stator 3x400VAC, LinMot Encoder	0150-1292
PS10-70x160U-BL-QJ-D01	Stator 3x400VAC, Sin/Cos Encoder 1Vpp, KTY	0150-2283
PS10-70x160U-BL-QJ-D02	Stator 3x400VAC, Sin/Cos Encoder 1Vpp, PTC	0150-2361
PS10-70x160U-BL-QJ-D03	Stator 3x400VAC, Sin/Cos 1Vpp, KTY on power connector	0150-2709
PL10-28x690/640	Slider for P10-70 'standard'	0150-2197

P10-70x160U/490-BL-QJ

Max. Stroke: 490 mm
Peak Force: 1120 N

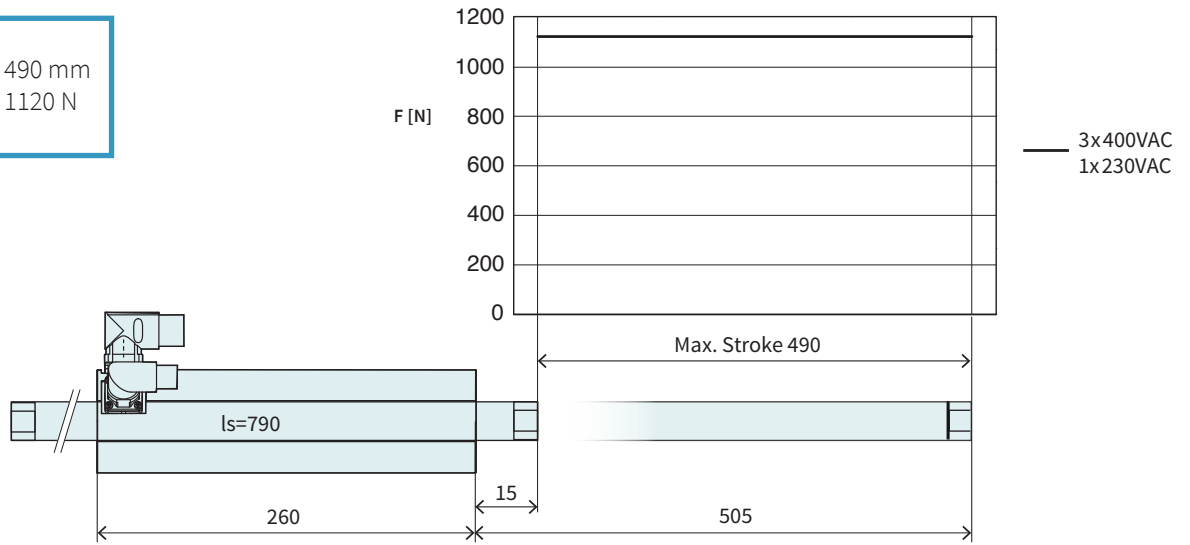

Dimensions in mm

Technical Data P10-70x160U/490			
Stroke			
Max. Stroke	mm (in)		490 (19.3)
Force			
Max. Force ¹ @ 1x230VAC	N (lbf)		1120 (252)
Max. Force ¹ @ 3x400VAC	N (lbf)		1120 (252)
Max. Cont. Force [Passive cooling / Fan / Fluid]	N (lbf)		130 / 200 / 350 (29 / 45 / 79)
Max. Border Force relative	%		100
Force Constant 1	N/A _{pk} (lbf/A _{pk})		56 (12.6)
Force Constant 2	N/A _{rms} (lbf/A _{rms})		79.2 (17.8)
Velocity			
Max. Velocity @ 1x230VAC	m/s (in/s)		3.2 (129.9)
Max. Velocity @ 3x400VAC	m/s (in/s)		5.6 (5.6)
Position Detection			
Repeatability	mm (in)		±0.05 (±0.002)
Linearity	%		± 0.2
Electrical Data			
Max. Current ¹ @ 1x230VAC	A _{pk} / A _{rms}		19.9 / 14
Max. Current ¹ @ 3x400VAC	A _{pk} / A _{rms}		19.9 / 14
Max. Cont. Current 1 [Passive cooling / Fan / Fluid]	A _{pk}		2.3 / 3.6 / 6.3
Max. Cont. Current 2 [Passive cooling / Fan / Fluid]	A _{rms}		1.7 / 2.5 / 4.4
Thermal Data			
Max. Winding Temperature (Sensor)	°C		90
Thermal Resistance [Passive cooling / Fan / Fluid]	°K/W		1.3 / 0.56 / 0.18
Thermal Time Constant [Passive cooling / Fan / Fluid]	s		2100 / 500 / 110
Mechanical Data			
Slider Length	mm (in)		790 (31)
Slider Mass	g (lb)		3710 (8.16)

1) Real time calculation of motor winding temperature is required (including monitoring).
 If temperature monitoring is only based on temperature sensor signal (missing thermal model calculation), 60 % of the peak value has to be taken instead.



Item	Description	Item-No.
PS10-70x160U-BL-QJ	Stator 3x400VAC, LinMot Encoder	0150-1292
PS10-70x160U-BL-QJ-D01	Stator 3x400VAC, Sin/Cos Encoder 1Vpp, KTY	0150-2283
PS10-70x160U-BL-QJ-D02	Stator 3x400VAC, Sin/Cos Encoder 1Vpp, PTC	0150-2361
PS10-70x160U-BL-QJ-D03	Stator 3x400VAC, Sin/Cos 1Vpp, KTY on power connector	0150-2709
PL10-28x790/740	Slider for P10-70 'standard'	0150-2198

P10-70x160U/590-BL-QJ

Max. Stroke: 590 mm
Peak Force: 1120 N

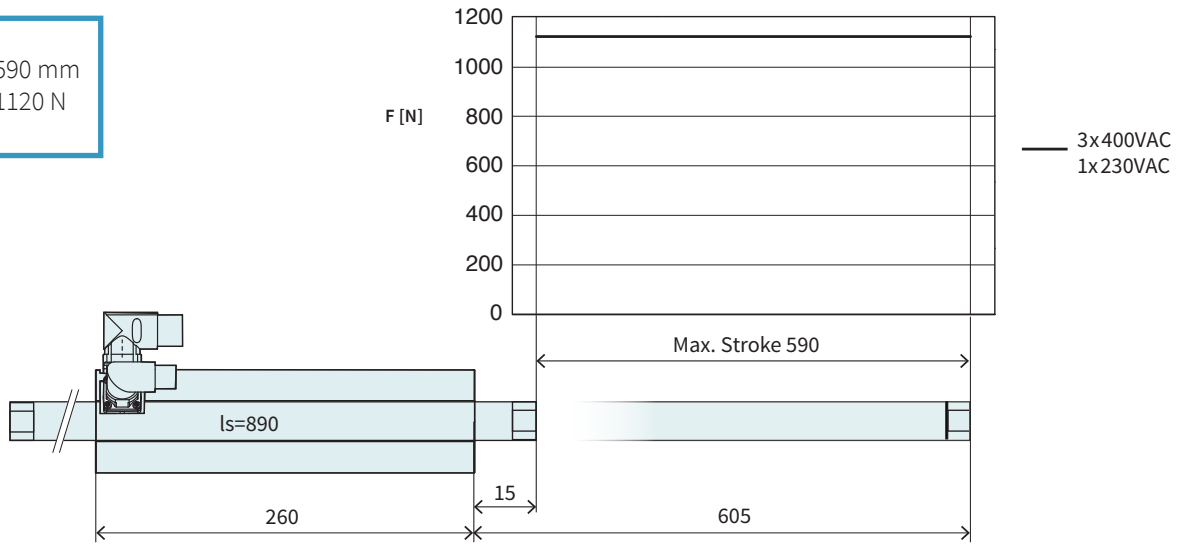

Dimensions in mm

Technical Data P10-70x160U/590			
Stroke			
Max. Stroke	mm (in)		590 (23.19)
Force			
Max. Force ¹ @ 1x230VAC	N (lbf)		1120 (252)
Max. Force ¹ @ 3x400VAC	N (lbf)		1120 (252)
Max. Cont. Force [Passive cooling / Fan / Fluid]	N (lbf)		130 / 200 / 350 (29 / 45 / 79)
Max. Border Force relative	%		100
Force Constant 1	N/A _{pk} (lbf/A _{pk})		56 (12.6)
Force Constant 2	N/A _{rms} (lbf/A _{rms})		79.2 (17.8)
Velocity			
Max. Velocity @ 1x230VAC	m/s (in/s)		3.2 (129.9)
Max. Velocity @ 3x400VAC	m/s (in/s)		5.6 (5.6)
Position Detection			
Repeatability	mm (in)		±0.05 (±0.002)
Linearity	%		± 0.2
Electrical Data			
Max. Current ¹ @ 1x230VAC	A _{pk} / A _{rms}		19.9 / 14
Max. Current ¹ @ 3x400VAC	A _{pk} / A _{rms}		19.9 / 14
Max. Cont. Current 1 [Passive cooling / Fan / Fluid]	A _{pk}		2.3 / 3.6 / 6.3
Max. Cont. Current 2 [Passive cooling / Fan / Fluid]	A _{rms}		1.7 / 2.5 / 4.4
Thermal Data			
Max. Winding Temperature (Sensor)	°C		90
Thermal Resistance [Passive cooling / Fan / Fluid]	°K/W		1.3 / 0.56 / 0.18
Thermal Time Constant [Passive cooling / Fan / Fluid]	s		2100 / 500 / 110
Mechanical Data			
Slider Length	mm (in)		890 (35)
Slider Mass	g (lb)		4180 (9.2)

1) Real time calculation of motor winding temperature is required (including monitoring).
 If temperature monitoring is only based on temperature sensor signal (missing thermal model calculation), 60 % of the peak value has to be taken instead.

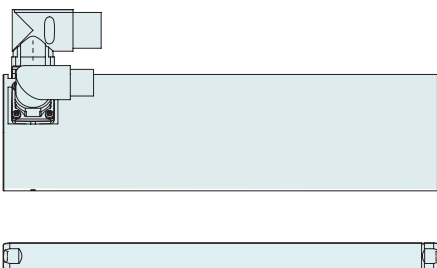

Item	Description	Item-No.
PS10-70x160U-BL-QJ	Stator 3x400VAC, LinMot Encoder	0150-1292
PS10-70x160U-BL-QJ-D01	Stator 3x400VAC, Sin/Cos Encoder 1Vpp, KTY	0150-2283
PS10-70x160U-BL-QJ-D02	Stator 3x400VAC, Sin/Cos Encoder 1Vpp, PTC	0150-2361
PS10-70x160U-BL-QJ-D03	Stator 3x400VAC, Sin/Cos 1Vpp, KTY on power connector	0150-2709
PL10-28x890/840	Slider for P10-70 'standard'	0150-2199

P10-70x160U/690-BL-QJ

Max. Stroke: 690 mm
Peak Force: 1120 N

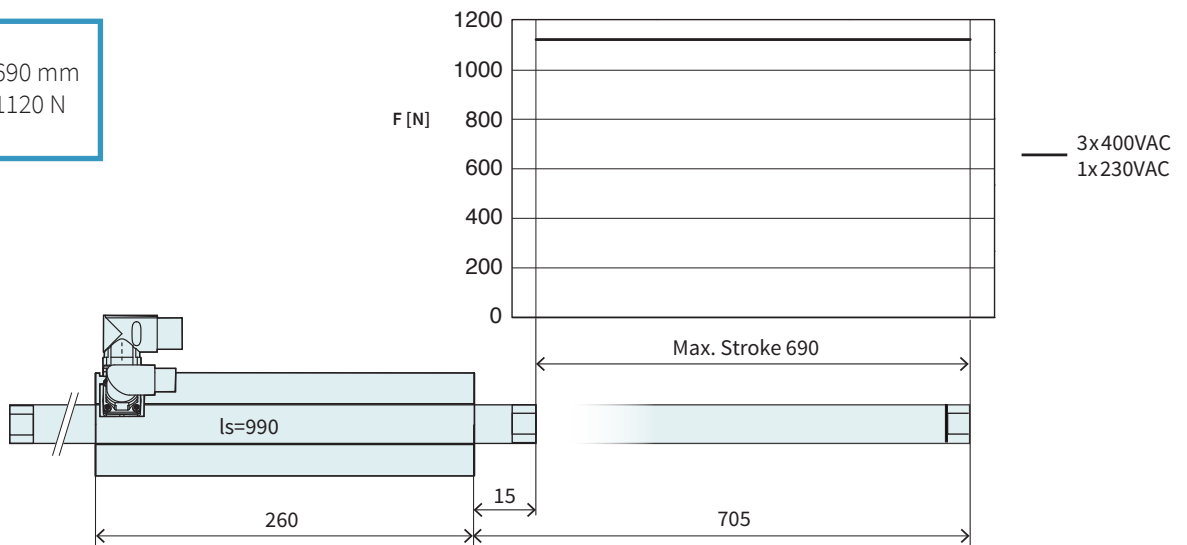

Dimensions in mm

Technical Data P10-70x160U/690

Stroke			
Max. Stroke	mm (in)		690 (27.19)
Force			
Max. Force ¹ @ 1x230VAC	N (lbf)		1120 (252)
Max. Force ¹ @ 3x400VAC	N (lbf)		1120 (252)
Max. Cont. Force [Passive cooling / Fan / Fluid]	N (lbf)		130 / 200 / 350 (29 / 45 / 79)
Max. Border Force relative	%		100
Force Constant 1	N/A _{pk} (lbf/A _{pk})		56 (12.6)
Force Constant 2	N/A _{rms} (lbf/A _{rms})		79.2 (17.8)
Velocity			
Max. Velocity @ 1x230VAC	m/s (in/s)		3.2 (129.9)
Max. Velocity @ 3x400VAC	m/s (in/s)		5.6 (5.6)
Position Detection			
Repeatability	mm (in)		±0.05 (±0.002)
Linearity	%		± 0.15
Electrical Data			
Max. Current ¹ @ 1x230VAC	A _{pk} / A _{rms}		19.9 / 14
Max. Current ¹ @ 3x400VAC	A _{pk} / A _{rms}		19.9 / 14
Max. Cont. Current 1 [Passive cooling / Fan / Fluid]	A _{pk}		2.3 / 3.6 / 6.3
Max. Cont. Current 2 [Passive cooling / Fan / Fluid]	A _{rms}		1.7 / 2.5 / 4.4
Thermal Data			
Max. Winding Temperature (Sensor)	°C		90
Thermal Resistance [Passive cooling / Fan / Fluid]	°K/W		1.3 / 0.56 / 0.18
Thermal Time Constant [Passive cooling / Fan / Fluid]	s		2100 / 500 / 110
Mechanical Data			
Slider Length	mm (in)		990 (39)
Slider Mass	g (lb)		4650 (10.23)

1) Real time calculation of motor winding temperature is required (including monitoring).
 If temperature monitoring is only based on temperature sensor signal (missing thermal model calculation), 60 % of the peak value has to be taken instead.

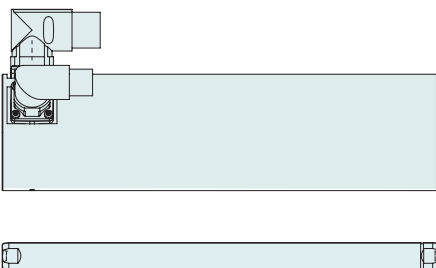

Item	Description	Item-No.
PS10-70x160U-BL-QJ	Stator 3x400VAC, LinMot Encoder	0150-1292
PS10-70x160U-BL-QJ-D01	Stator 3x400VAC, Sin/Cos Encoder 1Vpp, KTY	0150-2283
PS10-70x160U-BL-QJ-D02	Stator 3x400VAC, Sin/Cos Encoder 1Vpp, PTC	0150-2361
PS10-70x160U-BL-QJ-D03	Stator 3x400VAC, Sin/Cos 1Vpp, KTY on power connector	0150-2709
PL10-28x990/940	Slider for P10-70 'standard'	0150-2203

P10-70x160U/890-BL-QJ

Max. Stroke: 890 mm
Peak Force: 1120 N

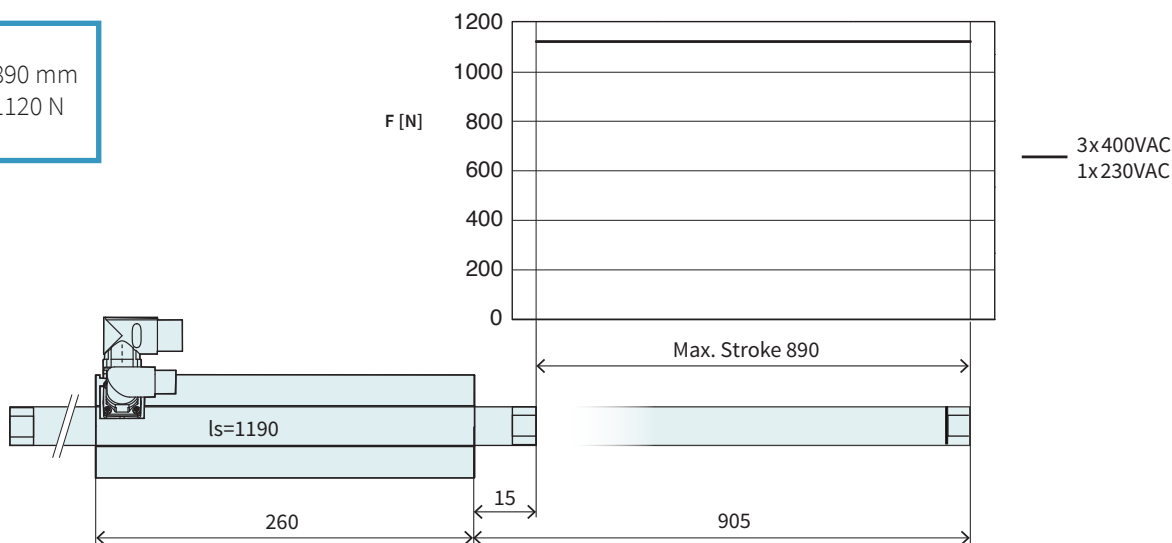

Dimensions in mm

Technical Data P10-70x160U/890

Stroke			
Max. Stroke	mm (in)		890 (34.99)
Force			
Max. Force ¹ @ 1x230VAC	N (lbf)		1120 (252)
Max. Force ¹ @ 3x400VAC	N (lbf)		1120 (252)
Max. Cont. Force [Passive cooling / Fan / Fluid]	N (lbf)		130 / 200 / 350 (29 / 45 / 79)
Max. Border Force relative	%		100
Force Constant 1	N/A _{pk} (lbf/A _{pk})		56 (12.6)
Force Constant 2	N/A _{rms} (lbf/A _{rms})		79.2 (17.8)
Velocity			
Max. Velocity @ 1x230VAC	m/s (in/s)		3.2 (129.9)
Max. Velocity @ 3x400VAC	m/s (in/s)		5.6 (5.6)
Position Detection			
Repeatability	mm (in)		±0.05 (±0.002)
Linearity	%		± 0.15
Electrical Data			
Max. Current ¹ @ 1x230VAC	A _{pk} / A _{rms}		19.9 / 14
Max. Current ¹ @ 3x400VAC	A _{pk} / A _{rms}		19.9 / 14
Max. Cont. Current 1 [Passive cooling / Fan / Fluid]	A _{pk}		2.3 / 3.6 / 6.3
Max. Cont. Current 2 [Passive cooling / Fan / Fluid]	A _{rms}		1.7 / 2.5 / 4.4
Thermal Data			
Max. Winding Temperature (Sensor)	°C		90
Thermal Resistance [Passive cooling / Fan / Fluid]	°K/W		1.3 / 0.56 / 0.18
Thermal Time Constant [Passive cooling / Fan / Fluid]	s		2100 / 500 / 110
Mechanical Data			
Slider Length	mm (in)		1190 (47)
Slider Mass	g (lb)		5590 (12.3)

1) Real time calculation of motor winding temperature is required (including monitoring).
 If temperature monitoring is only based on temperature sensor signal (missing thermal model calculation), 60 % of the peak value has to be taken instead.

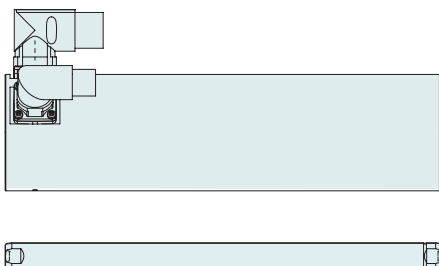

Item	Description	Item-No.
PS10-70x160U-BL-QJ	Stator 3x400VAC, LinMot Encoder	0150-1292
PS10-70x160U-BL-QJ-D01	Stator 3x400VAC, Sin/Cos Encoder 1Vpp, KTY	0150-2283
PS10-70x160U-BL-QJ-D02	Stator 3x400VAC, Sin/Cos Encoder 1Vpp, PTC	0150-2361
PS10-70x160U-BL-QJ-D03	Stator 3x400VAC, Sin/Cos 1Vpp, KTY on power connector	0150-2709
PL10-28x1190/1140	Slider for P10-70 'standard'	0150-2204

P10-70x160U/1090-BL-QJ

Max. Stroke: 1090 mm
Peak Force: 1120 N

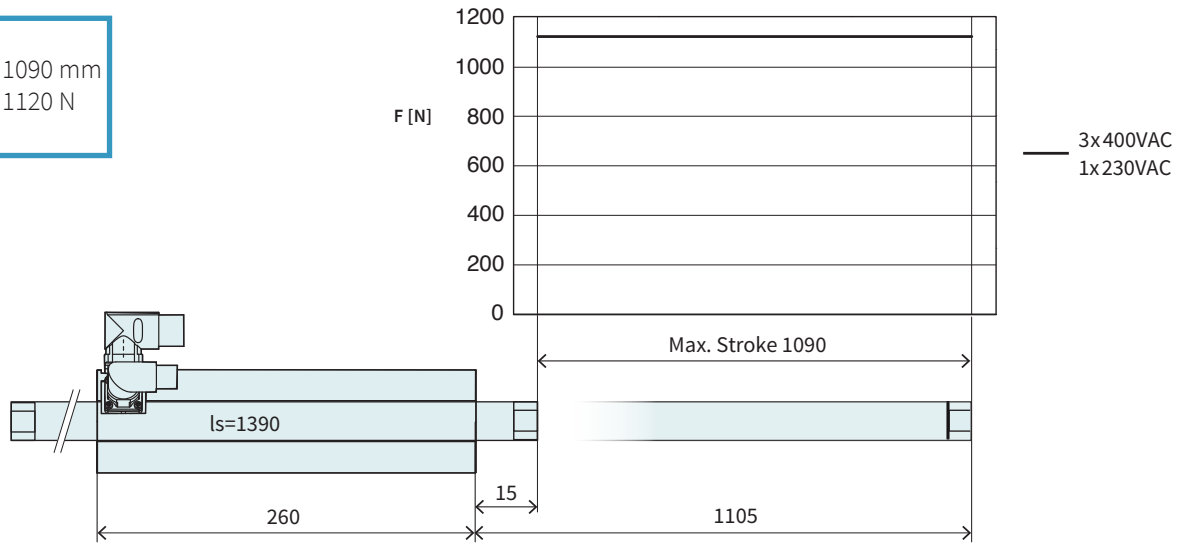

Dimensions in mm

Technical Data P10-70x160U/1090

Stroke			
Max. Stroke	mm (in)		1090 (42.89)
Force			
Max. Force ¹ @ 1x230VAC	N (lbf)		1120 (252)
Max. Force ¹ @ 3x400VAC	N (lbf)		1120 (252)
Max. Cont. Force [Passive cooling / Fan / Fluid]	N (lbf)		130 / 200 / 350 (29 / 45 / 79)
Max. Border Force relative	%		100
Force Constant 1	N/A _{pk} (lbf/A _{pk})		56 (12.6)
Force Constant 2	N/A _{rms} (lbf/A _{rms})		79.2 (17.8)
Velocity			
Max. Velocity @ 1x230VAC	m/s (in/s)		3.2 (129.9)
Max. Velocity @ 3x400VAC	m/s (in/s)		5.6 (5.6)
Position Detection			
Repeatability	mm (in)		±0.05 (±0.002)
Linearity	%		±0.15
Electrical Data			
Max. Current ¹ @ 1x230VAC	A _{pk} / A _{rms}		19.9 / 14
Max. Current ¹ @ 3x400VAC	A _{pk} / A _{rms}		19.9 / 14
Max. Cont. Current 1 [Passive cooling / Fan / Fluid]	A _{pk}		2.3 / 3.6 / 6.3
Max. Cont. Current 2 [Passive cooling / Fan / Fluid]	A _{rms}		1.7 / 2.5 / 4.4
Thermal Data			
Max. Winding Temperature (Sensor)	°C		90
Thermal Resistance [Passive cooling / Fan / Fluid]	°K/W		1.3 / 0.56 / 0.18
Thermal Time Constant [Passive cooling / Fan / Fluid]	s		2100 / 500 / 110
Mechanical Data			
Slider Length	mm (in)		1390 (55)
Slider Mass	g (lb)		6530 (14.37)

1) Real time calculation of motor winding temperature is required (including monitoring).
 If temperature monitoring is only based on temperature sensor signal (missing thermal model calculation), 60 % of the peak value has to be taken instead.



Item	Description	Item-No.
PS10-70x160U-BL-QJ	Stator 3x400VAC, LinMot Encoder	0150-1292
PS10-70x160U-BL-QJ-D01	Stator 3x400VAC, Sin/Cos Encoder 1Vpp, KTY	0150-2283
PS10-70x160U-BL-QJ-D02	Stator 3x400VAC, Sin/Cos Encoder 1Vpp, PTC	0150-2361
PS10-70x160U-BL-QJ-D03	Stator 3x400VAC, Sin/Cos 1Vpp, KTY on power connector	0150-2709
PL10-28x1390/1340	Slider for P10-70 'standard'	0150-2205

P10-70x160U/1290-BL-QJ

Max. Stroke: 1290 mm
Peak Force: 1120 N

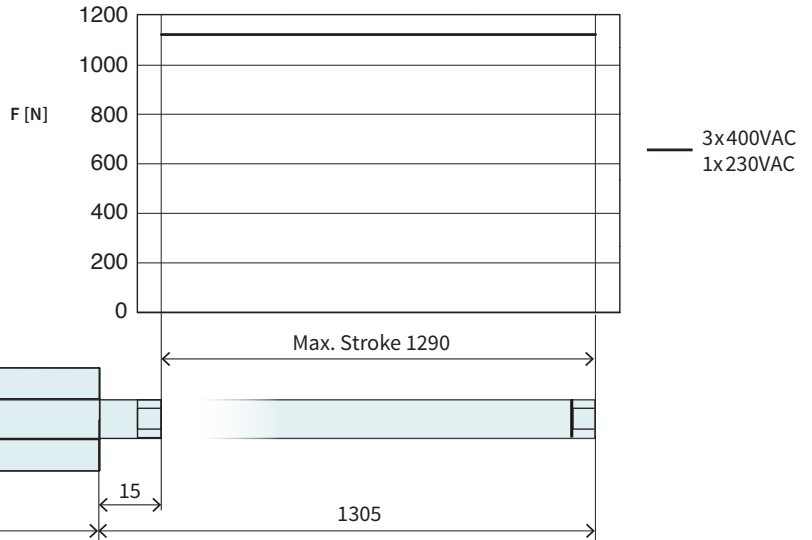

Dimensions in mm

Technical Data P10-70x160U/1290				
Stroke				
Max. Stroke	mm	(in)	1290	(50.79)
Force				
Max. Force ¹ @ 1x230VAC	N	(lbf)	1120	(252)
Max. Force ¹ @ 3x400VAC	N	(lbf)	1120	(252)
Max. Cont. Force [Passive cooling / Fan / Fluid]	N	(lbf)	130 / 200 / 350	(29 / 45 / 79)
Max. Border Force relative	%		100	
Force Constant 1	N/A _{pk}	(lbf/A _{pk})	56	(12.6)
Force Constant 2	N/A _{rms}	(lbf/A _{rms})	79.2	(17.8)
Velocity				
Max. Velocity @ 1x230VAC	m/s	(in/s)	3.2	(129.9)
Max. Velocity @ 3x400VAC	m/s	(in/s)	5.6	(5.6)
Position Detection				
Repeatability	mm	(in)	±0.05	(±0.002)
Linearity	%		± 0.15	
Electrical Data				
Max. Current ¹ @ 1x230VAC	A _{pk} / A _{rms}		19.9 / 14	
Max. Current ¹ @ 3x400VAC	A _{pk} / A _{rms}		19.9 / 14	
Max. Cont. Current 1 [Passive cooling / Fan / Fluid]	A _{pk}		2.3 / 3.6 / 6.3	
Max. Cont. Current 2 [Passive cooling / Fan / Fluid]	A _{rms}		1.7 / 2.5 / 4.4	
Thermal Data				
Max. Winding Temperature (Sensor)	°C		90	
Thermal Resistance [Passive cooling / Fan / Fluid]	°K/W		1.3 / 0.56 / 0.18	
Thermal Time Constant [Passive cooling / Fan / Fluid]	s		2100 / 500 / 110	
Mechanical Data				
Slider Length	mm	(in)	1590	(63)
Slider Mass	g	(lb)	7470	(16.43)

1) Real time calculation of motor winding temperature is required (including monitoring).
 If temperature monitoring is only based on temperature sensor signal (missing thermal model calculation), 60 % of the peak value has to be taken instead.



Item	Description	Item-No.
PS10-70x160U-BL-QJ	Stator 3x400VAC, LinMot Encoder	0150-1292
PS10-70x160U-BL-QJ-D01	Stator 3x400VAC, Sin/Cos Encoder 1Vpp, KTY	0150-2283
PS10-70x160U-BL-QJ-D02	Stator 3x400VAC, Sin/Cos Encoder 1Vpp, PTC	0150-2361
PS10-70x160U-BL-QJ-D03	Stator 3x400VAC, Sin/Cos 1Vpp, KTY on power connector	0150-2709
PL10-28x1590/1540	Slider for P10-70 'standard'	0150-2206

P10-70x160U/1490-BL-QJ

Max. Stroke: 1490 mm
Peak Force: 1120 N

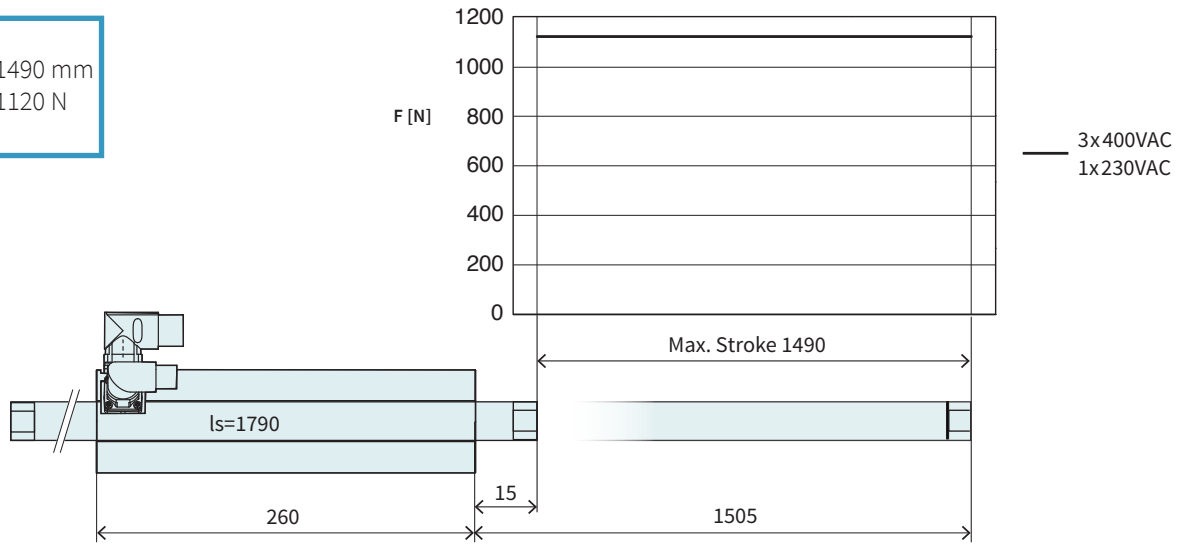

Dimensions in mm

Technical Data P10-70x160U/1490

Stroke			
Max. Stroke	mm (in)		1490 (58.7)
Force			
Max. Force ¹ @ 1x230VAC	N (lbf)		1120 (252)
Max. Force ¹ @ 3x400VAC	N (lbf)		1120 (252)
Max. Cont. Force [Passive cooling / Fan / Fluid]	N (lbf)		130 / 200 / 350 (29 / 45 / 79)
Max. Border Force relative	%		100
Force Constant 1	N/A _{pk} (lbf/A _{pk})		56 (12.6)
Force Constant 2	N/A _{rms} (lbf/A _{rms})		79.2 (17.8)
Velocity			
Max. Velocity @ 1x230VAC	m/s (in/s)		3.2 (129.9)
Max. Velocity @ 3x400VAC	m/s (in/s)		5.6 (5.6)
Position Detection			
Repeatability	mm (in)		±0.05 (±0.002)
Linearity	%		± 0.15
Electrical Data			
Max. Current ¹ @ 1x230VAC	A _{pk} / A _{rms}		19.9 / 14
Max. Current ¹ @ 3x400VAC	A _{pk} / A _{rms}		19.9 / 14
Max. Cont. Current 1 [Passive cooling / Fan / Fluid]	A _{pk}		2.3 / 3.6 / 6.3
Max. Cont. Current 2 [Passive cooling / Fan / Fluid]	A _{rms}		1.7 / 2.5 / 4.4
Thermal Data			
Max. Winding Temperature (Sensor)	°C		90
Thermal Resistance [Passive cooling / Fan / Fluid]	°K/W		1.3 / 0.56 / 0.18
Thermal Time Constant [Passive cooling / Fan / Fluid]	s		2100 / 500 / 110
Mechanical Data			
Slider Length	mm (in)		1790 (70)
Slider Mass	g (lb)		8413 (18.51)

1) Real time calculation of motor winding temperature is required (including monitoring).
 If temperature monitoring is only based on temperature sensor signal (missing thermal model calculation), 60 % of the peak value has to be taken instead.

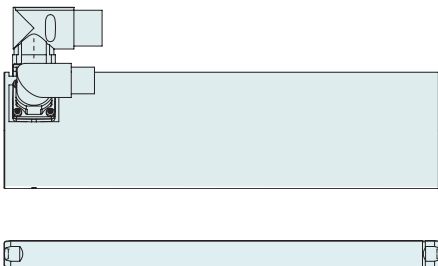

Item	Description	Item-No.
PS10-70x160U-BL-QJ	Stator 3x400VAC, LinMot Encoder	0150-1292
PS10-70x160U-BL-QJ-D01	Stator 3x400VAC, Sin/Cos Encoder 1Vpp, KTY	0150-2283
PS10-70x160U-BL-QJ-D02	Stator 3x400VAC, Sin/Cos Encoder 1Vpp, PTC	0150-2361
PS10-70x160U-BL-QJ-D03	Stator 3x400VAC, Sin/Cos 1Vpp, KTY on power connector	0150-2709
PL10-28x1790/1740	Slider for P10-70 'standard'	0150-2207

P10-70x160U/1690-BL-QJ

Max. Stroke: 1690 mm
Peak Force: 1120 N

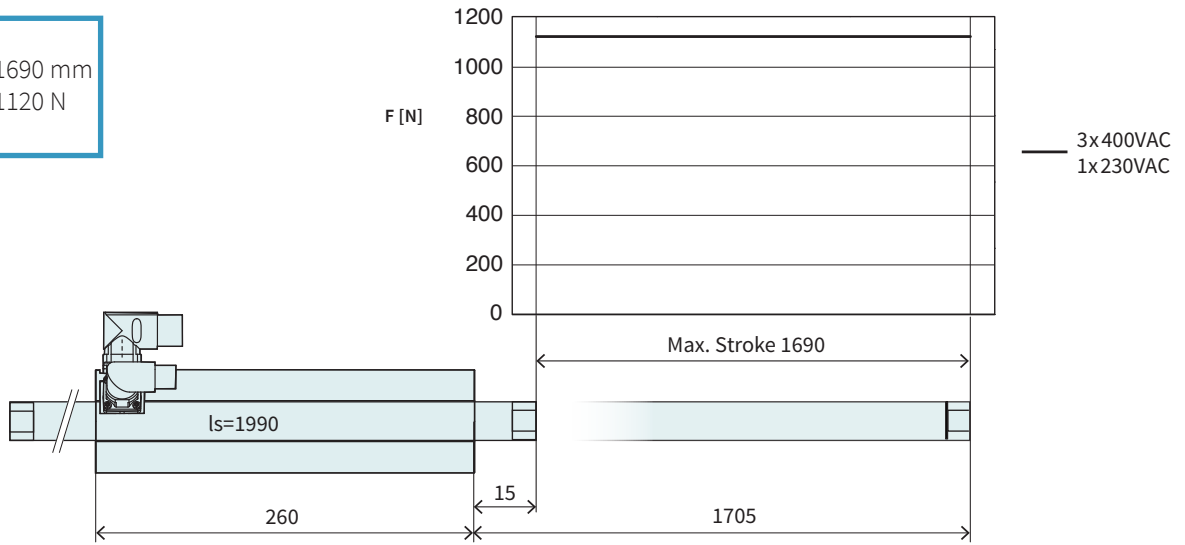

Dimensions in mm

Technical Data P10-70x160U/1690			
Stroke			
Max. Stroke	mm (in)	1690 (66.49)	
Force			
Max. Force ¹ @ 1x230VAC	N (lbf)	1120 (252)	
Max. Force ¹ @ 3x400VAC	N (lbf)	1120 (252)	
Max. Cont. Force [Passive cooling / Fan / Fluid]	N (lbf)	130 / 200 / 350 (29 / 45 / 79)	
Max. Border Force relative	%	100	
Force Constant 1	N/A _{pk} (lbf/A _{pk})	56 (12.6)	
Force Constant 2	N/A _{rms} (lbf/A _{rms})	79.2 (17.8)	
Velocity			
Max. Velocity @ 1x230VAC	m/s (in/s)	3.2 (129.9)	
Max. Velocity @ 3x400VAC	m/s (in/s)	5.6 (5.6)	
Position Detection			
Repeatability	mm (in)	±0.05 (±0.002)	
Linearity	%	± 0.15	
Electrical Data			
Max. Current ² @ 1x230VAC	A _{pk} / A _{rms}	19.9 / 14	
Max. Current ² @ 3x400VAC	A _{pk} / A _{rms}	19.9 / 14	
Max. Cont. Current 1 [Passive cooling / Fan / Fluid]	A _{pk}	2.3 / 3.6 / 6.3	
Max. Cont. Current 2 [Passive cooling / Fan / Fluid]	A _{rms}	1.7 / 2.5 / 4.4	
Thermal Data			
Max. Winding Temperature (Sensor)	°C	90	
Thermal Resistance [Passive cooling / Fan / Fluid]	°K/W	1.3 / 0.56 / 0.18	
Thermal Time Constant [Passive cooling / Fan / Fluid]	s	2100 / 500 / 110	
Mechanical Data			
Slider Length	mm (in)	1990 (78)	
Slider Mass	g (lb)	9350 (20.57)	

1) Real time calculation of motor winding temperature is required (including monitoring).
 If temperature monitoring is only based on temperature sensor signal (missing thermal model calculation), 60 % of the peak value has to be taken instead.

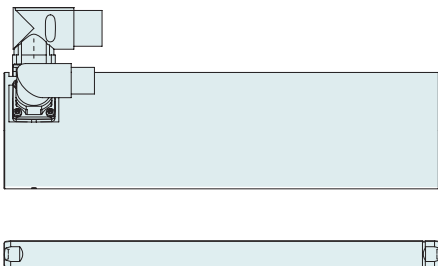

Item	Description	Item-No.
PS10-70x160U-BL-QJ	Stator 3x400VAC, LinMot Encoder	0150-1292
PS10-70x160U-BL-QJ-D01	Stator 3x400VAC, Sin/Cos Encoder 1Vpp, KTY	0150-2283
PS10-70x160U-BL-QJ-D02	Stator 3x400VAC, Sin/Cos Encoder 1Vpp, PTC	0150-2361
PS10-70x160U-BL-QJ-D03	Stator 3x400VAC, Sin/Cos 1Vpp, KTY on power connector	0150-2709
PL10-28x1990/1940	Slider for P10-70 'standard'	0150-2208

Linear Guides H10



HM10-70x160/90		Linear Module 70x160 with 90 mm Stroke		
→	H-Guide	H10-70x160/90	H-Guide for P10-70x160, Stroke max. 90 mm	0150-5409
	Stator	PS10-70x160U-BL-QJ	Stator 3x400VAC, LinMot Encoder	0150-1292
		PS10-70x160U-BL-QJ-D01	Stator 3x400VAC, Sin/Cos Encoder 1Vpp, KTY	0150-2283
		PS10-70x160U-BL-QJ-D02	Stator 3x400VAC, Sin/Cos Encoder 1Vpp, PTC	0150-2361
		PS10-70x160U-BL-QJ-D03	Stator 3x400VAC, Sin/Cos 1Vpp, KTY on power connector	0150-2709
Slider	PL10-28x390/340	Slider for P10-70 'standard'	0150-2194	
HM10-70x160/190		Linear Module 70x160 with 190 mm Stroke		
→	H-Guide	H10-70x160/190	H-Guide for P10-70x160, Stroke max. 190 mm	0150-5410
	Stator	PS10-70x160U-BL-QJ	Stator 3x400VAC, LinMot Encoder	0150-1292
		PS10-70x160U-BL-QJ-D01	Stator 3x400VAC, Sin/Cos Encoder 1Vpp, KTY	0150-2283
		PS10-70x160U-BL-QJ-D02	Stator 3x400VAC, Sin/Cos Encoder 1Vpp, PTC	0150-2361
		PS10-70x160U-BL-QJ-D03	Stator 3x400VAC, Sin/Cos 1Vpp, KTY on power connector	0150-2709
Slider	PL10-28x490/440	Slider for P10-70 'standard'	0150-2195	
HM10-70x160/290		Linear Module 70x160 with 290 mm Stroke		
→	H-Guide	H10-70x160/290	H-Guide for P10-70x160, Stroke max. 290 mm	0150-5411
	Stator	PS10-70x160U-BL-QJ	Stator 3x400VAC, LinMot Encoder	0150-1292
		PS10-70x160U-BL-QJ-D01	Stator 3x400VAC, Sin/Cos Encoder 1Vpp, KTY	0150-2283
		PS10-70x160U-BL-QJ-D02	Stator 3x400VAC, Sin/Cos Encoder 1Vpp, PTC	0150-2361
		PS10-70x160U-BL-QJ-D03	Stator 3x400VAC, Sin/Cos 1Vpp, KTY on power connector	0150-2709
Slider	PL10-28x590/540	Slider for P10-70 'standard'	0150-2196	

FIND MORE PRODUCT DETAILS IN THE CHAPTER "LINEAR GUIDES".

4

HM10-70x160/390 | Linear Module 70x160 with 390 mm Stroke

→	H-Guide	H10-70x160/390	H-Guide for P10-70x160, Stroke max. 390 mm	0150-5412
	Stator	PS10-70x160U-BL-QJ	Stator 3x400VAC, LinMot Encoder	0150-1292
		PS10-70x160U-BL-QJ-D01	Stator 3x400VAC, Sin/Cos Encoder 1Vpp, KTY	0150-2283
		PS10-70x160U-BL-QJ-D02	Stator 3x400VAC, Sin/Cos Encoder 1Vpp, PTC	0150-2361
		PS10-70x160U-BL-QJ-D03	Stator 3x400VAC, Sin/Cos 1Vpp, KTY on power connector	0150-2709
Slider	PL10-28x690/640	Slider for P10-70 'standard'	0150-2197	

HM10-70x160/490 | Linear Module 70x160 with 490 mm Stroke

→	H-Guide	H10-70x160/490	H-Guide for P10-70x160, Stroke max. 490 mm	0150-5413
	Stator	PS10-70x160U-BL-QJ	Stator 3x400VAC, LinMot Encoder	0150-1292
		PS10-70x160U-BL-QJ-D01	Stator 3x400VAC, Sin/Cos Encoder 1Vpp, KTY	0150-2283
		PS10-70x160U-BL-QJ-D02	Stator 3x400VAC, Sin/Cos Encoder 1Vpp, PTC	0150-2361
		PS10-70x160U-BL-QJ-D03	Stator 3x400VAC, Sin/Cos 1Vpp, KTY on power connector	0150-2709
Slider	PL10-28x790/740	Slider for P10-70 'standard'	0150-2198	

Accessories

→	Fan	HV01-37/48	Fan cooling for H01-37/48 & PF02-37/48	0150-5051
---	-----	------------	--	---------------------------

Motor Cable

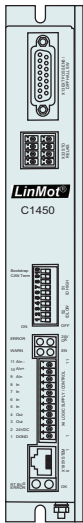

C1400



E1400

B Connector MC10-B/m

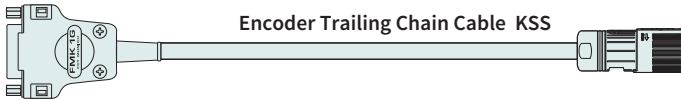
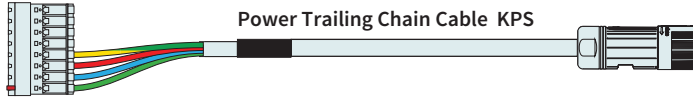

Q Connector MC10-Q/f

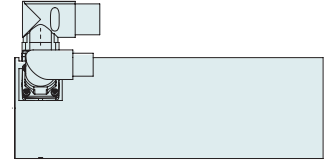

P10-70x160U

D15 Connector MC01-D15/f

J Connector MC10-J/f

L Connector MC10-L/m

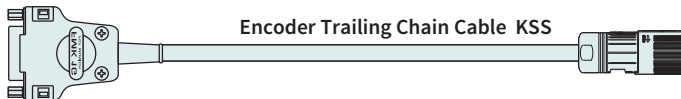
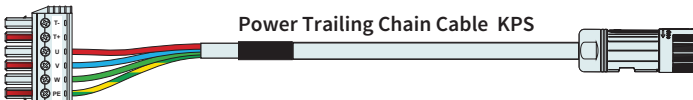

Q Connector MC10-Q/f



P10-70x160U

D15 Connector MC01-D15/f

J Connector MC10-J/f

ORDERING INFORMATION

TRAILING CHAIN CABLE FOR LINMOT DRIVES		
Item	Description	Item-No.
KPS15-04-L/Q-3	Power Trailing Chain Cable E1400/P10-70, 3 m	0150-2266
KPS15-04-L/Q-5	Power Trailing Chain Cable E1400/P10-70, 5 m	0150-2261
KPS15-04-L/Q-8	Power Trailing Chain Cable E1400/P10-70, 8 m	0150-2267
KPS15-04-L/Q-12	Power Trailing Chain Cable E1400/P10-70, 12 m	0150-2268
KPS15-04-L/Q-	Power Trailing Chain Cable L/Q-, Custom length	0150-3388
KPS15-04-B/Q-3	Power Trailing Chain Cable C1400/P10-70, 3 m	0150-3660
KPS15-04-B/Q-5	Power Trailing Chain Cable C1400/P10-70, 5 m	0150-3661
KPS15-04-B/Q-8	Power Trailing Chain Cable C1400/P10-70, 8 m	0150-3662
KPS15-04-B/Q-12	Power Trailing Chain Cable C1400/P10-70, 12 m	0150-3663
KPS15-04-B/Q-	Power Trailing Chain Cable B/Q-, Custom length	0150-3608

TRAILING CHAIN CABLE FOR LINMOT DRIVES

Item	Description	Item-No.
KSS 05-02/08-D15/J-3	Encoder Trailing Chain Cable D15/J, 3 m	0150-2263
KSS 05-02/08-D15/J-5	Encoder Trailing Chain Cable D15/J, 5 m	0150-2262
KSS 05-02/08-D15/J-8	Encoder Trailing Chain Cable D15/J, 8 m	0150-2264
KSS 05-02/08-D15/J-12	Encoder Trailing Chain Cable D15/J, 12 m	0150-2265
KSS 05-02/08-D15(f)-45°/J-	Encoder Trailing Chain Cable D15/J-, Custom length	0150-3389

TRAILING CHAIN CABLE FOR STATOR SERIES D01 / D02

Item	Description	Item-No.
KPS15-04-.../Q-10	Power Trailing Chain Cable .../Q, 10 m for D0x	0150-2376
KPS15-04-./Q-	Power Trailing Chain Cable .../Q, for D0x, Custom length	0150-3491
KSS05-02/13-./J-10	Encoder Trailing Chain Cable ./J, 10 m for D0x	0150-2377
KSS05-02/13-./J-	Encoder Trailing Chain Cable ./J, for D0x, Custom length	0150-3492
KPS15-04	Power Trailing Chain Cable P10-70 (per m)	0150-2257
KSS05-02/13	Trailing Chain Cable Encoder P10-...-Dxx (per m)	0150-2259

TRAILING CHAIN CABLE FOR STATOR SERIES D03

Item	Description	Item-No.
KPS15-04/04.../Q-10	Power Trailing Chain Cable .../Q, 10 m for D03	0150-3654
KPS15-04/04-./Q-	Power Trailing Chain Cable .../Q, for D03, Custom length	0150-3579
KSS05-02/06-./J-10	Encoder Trailing Chain Cable ./J, 10 m for D03	0150-3655
KSS05-02/06-./J-	Encoder Trailing Chain Cable ./J, for D03, Custom length	0150-3611
KPS15-04/04	Power Trailing Chain Cable P10-...-Dx3 (per m)	0150-2269
KSS05-02/06	Trailing Chain Cable Encoder P10-...-Dx3 (per m)	0150-2490

CONNECTOR

Item	Description	Item-No.
MC10-L/m	Connector Power E1400/X2	0150-3382
MC01-D15/f	Motor Connector D15 (f)	0150-3136
MC10-Q/f	Connector Power PS10-70	0150-2268
MC10-J/f	Connector Encoder PS10-70	0150-2269

MOTOR FLANGES



Item	Description	Item-No.
PF10-70x190	Flange for PS10-70x160	0150-2273



Item	Description	Item-No.
PF10-70x190-FC	Flange for PS10-70x160 fluid cooling	0150-2292



Item	Description	Item-No.
PF11-70x190-FC	Flange for PS10-70x160 fluid cooling	0150-2823

FIND MORE PRODUCT DETAILS IN THE CHAPTER "ACCESSORIES".

FANS



Item	Description	Item-No.
HV01-37/48	Fan cooling for H01-37/48 & PF02-37/48	0150-5051

FIND MORE PRODUCT DETAILS IN THE CHAPTER "ACCESSORIES".

SLIDER MOUNTING



Item	Description	Item-No.
PLF01-28	Fixed Bearing Set for 27/28 mm sliders	0150-3087
PLF01-28-SS	Fixed Bearing Set for 27/28 mm sliders, stainless steel	0150-3297
PLL01-28	Floating Bearing for 28 mm sliders	0150-3094
PLM01-28-MK	Mounting Kit for 28 mm sliders	0150-3095

FIND MORE PRODUCT DETAILS IN THE CHAPTER "ACCESSORIES".

BEARING KIT



Item	Description	Item-No.
PB10-70x160-L	Bearing Kit for PS10-70x160	0150-3432

FIND MORE PRODUCT DETAILS IN THE CHAPTER "ACCESSORIES".

LUBRICANT RESERVOIR



Item	Description	Item-No.
PA10-70/28	Lubricant reservoir for PS10-70 with lubricating nipple	0150-3543

FIND MORE PRODUCT DETAILS IN THE CHAPTER "ACCESSORIES".

EXTERNAL POSITION SENSORS

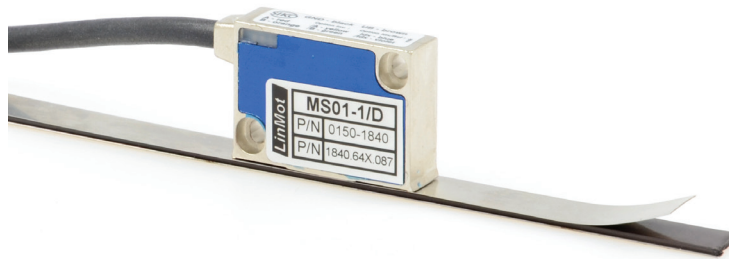

Item	Description	Item-No.
MS01-1/D	Linear Encoder 1µm, A/B (for incremental strip)	0150-1840
MB01-1000	Magnetic incremental strip for MS01-1/D, per cm	0150-1963
KS025-D15/D-Encoder	Encoder Cable (Length in m)	0150-3168

FIND MORE PRODUCT DETAILS IN THE CHAPTER "ACCESSORIES".



Item	Description	Item-No.
MS01-1/D-SSI	Linear Encoder 1µm, A/B (for absolute strip)	0150-2095
MB01-1000-ABS	Magnetic absolute strip for MS01-1/D-SSI (per cm)	0150-2096
EC01-ABS/ENC-12-S	MS01-1/D-SSI Encoder connector straight	0150-3616
KSS01-12-D15/ABS-ENC	Special cable for MS01-1/D-SSI on C1100/C1200/C1400/E1200/E1400 Drives	0150-3652

FIND MORE PRODUCT DETAILS IN THE CHAPTER "ACCESSORIES".

