

SNAP PAC S-SERIES CONTROLLERS

Features

- > Powerful standalone industrial controller
- > Two independent 10/100 Mbps Ethernet interfaces for use on standard Ethernet networks
- > RS-232 and RS-485 serial ports for connection to serial devices, including Opto 22 serial I/O units and PPP host communication.
- > Multiple protocol support: TCP/IP, HTTP/HTTPS, EtherNet/IP™, Modbus™ /TCP, SNMP, SMTP, FTP, and OptoMMP™
- > IIoT and developer ready with a RESTful API to securely access data
- > FTP server/client capability; includes file system and removable storage (microSD card)
- > Use two identical models for controller redundancy



SNAP-PAC-S2 controller

DESCRIPTION

A SNAP PAC S-series programmable automation controller (PAC) provides powerful, real-time control and communication to meet your industrial control, monitoring, Industrial Internet of Things (IIoT), and data acquisition needs. As part of the Opto 22 SNAP PAC System, one of these compact, industrially hardened controllers can handle multiple control, automation, and data acquisition tasks involving digital and analog control, serial string handling, PID, and enterprise and Internet connectivity.

Connecting to Opto 22 serial- and Ethernet-based I/O systems, a SNAP PAC S-series controller runs control programs written in Opto 22's PAC Control™ software to monitor and control a wide range of devices and equipment. SNAP PAC S-series controllers are well suited to original equipment manufacturers (OEMs), system integrators, and end-users in process control, discrete manufacturing, or hybrid industries and applications.

SNAP PAC S-series controllers include a RESTful API (representational state transfer application program interface), so you can use the language of your choice to securely access controller tag data and use it for business purposes.

Ethernet Communication

All SNAP PAC S-series programmable automation controllers communicate over standard 10/100 Mbps Ethernet networks. The controllers can also be used in an independent control network built with standard, off-the-shelf Ethernet hardware.

SNAP PAC S-series controllers include two 10/100 Mbps Ethernet interfaces for networking through an Ethernet switch to Ethernet hosts, as well as SNAP PAC brains and I/O, which provide local intelligence and the connections to digital and analog sensors and actuators as well as serial devices. The Ethernet interfaces support Auto MDI-X, which means you can use a standard straight-through Ethernet cable; a crossover cable is not needed for direct connection to a PC.

The two independent Ethernet ports have separate IP addresses that can be used with PAC Project™ Professional software to set up redundant network links to safeguard the availability and reliability of an I/O system, or to segment a control system's network from the enterprise LAN.

Part Numbers

Part	Description
SNAP-PAC-S1	Ethernet-based programmable automation controller with 2 Ethernet interfaces, RESTful API
SNAP-PAC-S1-FM	Ethernet-based programmable automation controller with 2 Ethernet interfaces, RESTful API, Factory Mutual approved
SNAP-PAC-S2	Ethernet-based programmable automation controller with 2 Ethernet interfaces and 4 serial ports, RESTful API
SNAP-PSDIN	SNAP-PAC-S1 controller DIN-rail adapter
SNAP-S2DIN	SNAP-PAC-S2 controller DIN-rail adapter

Serial Communication

SNAP PAC S-series controllers provide RS-232 and RS-485 communication as follows:

The **SNAP-PAC-S1** and **SNAP-PAC-S1-FM** have two RS-232 serial ports that support general-purpose communication with serial devices; you can send and receive data from one or two serial devices connected directly to the controller. Port 0 can be connected to a modem using PPP (Point-to-Point Protocol). These controllers also have one pluggable two-wire RS-485 port that can be used for SNAP PAC or *mistic* serial I/O units. For additional serial interfaces, you can add one or more SNAP serial communication modules on SNAP PAC racks connected to the controller.

The **SNAP-PAC-S2** has four serial ports that can each be configured using PAC Manager as either RS-232 or RS-485 (2-wire or 4-wire). These serial ports can be used for I/O or for general-purpose serial communication. For the default configuration settings of these ports, see form 1592, [SNAP PAC S-series User's Guide](#).

Configured as RS-232, the ports support remote serial device communication, and any one of the ports can be configured as a PPP modem connection for creating a TCP/IP network over PSTN (Public Switched Telephone Network) lines. Configured as RS-485, the serial ports connect to legacy Opto 22 *mistic*™ I/O units, including the serial B3000 brain and remote *mistic* bricks, and to SNAP PAC SB-series serial brains.

For additional serial host interfaces, you can add one or more SNAP serial communication modules on attached SNAP Ethernet-based I/O units.

Controller Redundancy

Two identical SNAP PAC S-series controllers can be used to form a redundant system, where one controller actively runs the control program and the other is ready to take over immediately if the first one should fail.

Besides two identical PACs, a redundant system requires PAC Professional 9.0 or newer (see “[Software](#),” below), and the SNAP PAC Redundancy Option Kit. For more information, see form 1901, [SNAP PAC Redundancy Option Kit Data Sheet](#), and form 1831, [SNAP PAC System Redundancy User's Guide](#), both available on our website.

Backward Compatibility

S-series controllers have RS-485 serial interfaces for connecting to Opto 22's legacy *mistic* I/O units. The SNAP-PAC-S1 and SNAP-PAC-S1-FM have one RS-485 port, and the SNAP-PAC-S2 can be configured with up to four.

This connectivity with legacy serial-based I/O systems, combined with PAC Control Professional's ability to import control programs (or

strategies) written in OptoControl™ software, provides a migration path to integrate older Opto 22 I/O systems into modern control hardware running on Ethernet networks.

For detailed information on updating control strategies and integrating legacy control hardware into modern systems, see form 1692, [FactoryFloor to PAC Project Migration Technical Note](#).

Forward Compatibility

SNAP PAC S-series controllers are also compatible with newer *groov* EPIC processors and *groov* RIO edge I/O units, which add industrial IoT data communications and security features to your system. Both *groov* EPIC and *groov* RIO can be used as I/O units with an S-series controller.

If you're not using serial-based I/O units with your system and don't require controller redundancy, consider purchasing a *groov* EPIC processor instead of a SNAP PAC S-series controller. For more information, see the [groov EPIC system](#) on our website or contact our pre-sales engineers.

SOFTWARE

SNAP PAC controllers use Opto 22's **PAC Project** Microsoft® Windows®-compatible automation software for control programming, human-machine-interface (HMI) development, and OPC and database connectivity. Two versions of PAC Project are available:

- **PAC Project Basic** includes PAC Control for developing control programs, PAC Display™ for creating operator interfaces, and PAC Manager™ configuration software.
- **PAC Project Professional** adds expanded versions of PAC Control and PAC Display, plus OptoOPCServer™ software for exchanging data with OPC 2.0-compliant client software applications, OptoDataLink™ for exchanging SNAP PAC System data with ODBC-compliant databases, and a SoftPAC™ software-based controller for PC-based control.

Applications included in the PAC Project software suite are:

PAC Control Basic is a graphical, flowchart-based programming tool for machine control and process applications. Using PAC Control, you create, download, and run strategies on a SNAP PAC controller. In addition to flowchart programming with subroutine capability, PAC Control includes a powerful, built-in scripting language based on C and other procedural languages. **PAC Control Professional** adds capabilities to import OptoControl strategies, to support *mistic* I/O units, and to use a SNAP PAC controller's independent Ethernet ports to segment communication links.

PAC Display Basic is an intuitive HMI package for building operator interfaces, or *projects*, for communicating with a SNAP PAC controller. PAC Display offers a full-featured HMI including alarming, trending, and a built-in library of 3,000 industrial automation graphics.

PAC Display Professional adds the ability to import projects created in OptoDisplay, part of the Opto 22 FactoryFloor[®] software suite, and to use redundant communication links on SNAP PAC controllers. PAC Display Professional can also connect to Ethernet-based FactoryFloor controllers running OptoControl strategies or ioProject controllers running ioControl strategies.

OptoOPCServer (PAC Project Professional only) is a fast, efficient OPC 2.0-compliant server for communicating with many Opto 22 products, including SNAP PAC controllers running PAC Control strategies, SNAP PAC brains, SNAP Ultimate controller/brains, SNAP Ethernet and SNAP Simple brains, and Ethernet-based FactoryFloor controllers running OptoControl strategies.

Using OptoOPCServer, you can consolidate data from all these Opto 22 systems into the OPC client software of your choice, such as third-party HMI and data acquisition packages, and custom software applications you create with tools such as Visual C++[®].

OptoDataLink (PAC Project Professional only) transparently provides multiple connections for data exchange with popular databases such as Microsoft SQL Server, Microsoft Access, and MySQL. OptoDataLink connects your SNAP PAC system with the tools used for making business decisions, bringing real-time, accurate data to decision makers.

SoftPAC (PAC Project Professional only) is a software-based programmable automation controller (PAC) designed for PC-based control. Programmed just like an Opto 22 hardware PAC, SoftPAC runs your PAC Control strategy independently on an embedded or standalone PC. SoftPAC takes advantage of a PC's speed and file

capabilities for applications requiring extended file storage, frequent access to files, or math-intensive processes.

PAC Manager is a utility application for assigning IP addresses to SNAP PAC controllers and brains, reading or changing basic controller configuration, upgrading firmware, and inspecting or testing controllers and I/O.

Software Availability

PAC Project Basic is included with SNAP PAC controllers and is a free download from the Opto 22 website. PAC Project Professional is available for purchase. You can also separately purchase PAC Control Professional, PAC Display Professional, OptoOPCServer, OptoDataLink, and SoftPAC as needed. For additional information, see form 1699, [PAC Project Data Sheet](#).

RESTful API

Ready for the Industrial Internet of Things (IIoT)? Need to use controller data for business purposes? Your SNAP PAC controller's built-in RESTful application program interface (API) lets you exchange data easily using the architecture of the Internet and the language of your choice.

You can query PAC Control strategy tags with HTTPS (Basic Auth) using your favorite programming language—PHP, .NET, Node.js, Python, or others. Tag data from I/O points and controller variables is returned as JSON.

You can set up authentication keys with permissions for either read-only or read-write, as necessary for your application. The RESTful API is included in SNAP PAC firmware R9.5a and PAC Project 9.5 (or higher). See developer.opto22.com for complete information.

I/O Units Supported

S-Series Controller	Supported I/O units located on:	
	An Ethernet network	A serial network
SNAP-PAC-S1 SNAP-PAC-S1-FM SNAP-PAC-S2	SNAP-PAC-R1	GRV-R7-MM1001-10
	SNAP-PAC-R1-B	GRV-R7-MM2001-10
	SNAP-PAC-R1-FM	G4EB2
	SNAP-PAC-R2	G4D32EB2
	SNAP-PAC-R2-FM	G4D32EB2-UPG
	SNAP-PAC-EB1	SNAP-UP1-ADS*
	SNAP-PAC-EB1-FM	SNAP-B3000-ENET*
	SNAP-PAC-EB2	SNAP-ENET-D64*
	SNAP-PAC-EB2-FM	SNAP-ENET-S64*
	GRV-EPIC-PR1	SNAP-ENET-RTC*
	GRV-EPIC-PR2	
	SNAP-PAC-SB1	
	SNAP-PAC-SB2	
	B3000*	
	B3000-B*	
	SNAP-BRS*	
	B100*	
	B200*	
	G4D16R*	
	G4D32RS*	
	G4A8R*	

* Legacy I/O processors; not recommended for new development

TECHNICAL SPECIFICATIONS

Specifications are continued on the following page.

Processor	266 MHz 32-bit ColdFire [®] 5475 with integrated floating-point unit (FPU)
Memory	SNAP-PAC-S1 and SNAP-PAC-S2 Total RAM: 32 MB Total RAM for PAC Control Strategies: 16 MB Battery-backed RAM: 8 MB RAM File Storage: 2.5 MB Flash File Storage: 4 MB
Removable storage	(Models with manufacture dates of June 2014 and newer. Requires firmware R9.4a or higher and loader R6.1a or higher) microSD card slot: supports microSD or microSDHC cards to 32 GB. (Models with manufacture dates of November 2008 through May 2014 with firmware R8.4 or higher) microSD card slot: supports microSD cards up to 2 GB.
Backup battery	SNAP-PAC-S1s with serial number 625654 or higher and all SNAP-PAC-S2s: Rechargeable (recharges whenever the brain has power), 1-year power-off data retention (replacement part number: SNAP-PAC-BATTERY-ML2430). SNAP-PAC-S1s with serial number 625653 or lower: User-replaceable 3.6-volt TL 5242 /W lithium, 10-year minimum power-off data retention (replacement part number: G4BATT32).
Ethernet Communication to host and I/O	Two independent 10/100 Mbps Ethernet network interfaces (RJ-45 connectors). Each interface has a separate IP address (separate subnet). Supports Auto MDI-X (crossover cable not needed).
Serial Communication	SNAP-PAC-S1 RS-232 serial: Two RS-232 serial ports (one DB-9 and one pluggable connector); one port has full handshaking. PPP is supported only on port 0. Buffer size: 512 bytes each for RX and TX. RS-485 serial: One RS-485 serial port (pluggable connector); two-wire RS-485; optional <i>mistic</i> signal interrupts. Range (serial multidrop): 32 stations maximum on a segment (including PC, controller, and I/O units); up to 3000 ft (914 m) on a segment. Buffer size: 512 bytes each for RX and TX. SNAP-PAC-S2 Four serial ports that can be used as general purpose ports or for serial I/O units; each port is software configurable as either RS-232 (Tx, Rx, COM, DTR, DCD, RTS, CTS) or as RS-485 (2-wire, 4-wire, optional termination, optional biasing); optional <i>mistic</i> signal interrupts. Buffer size: 512 bytes each for RX and TX.
Power requirements	8–32 VDC ± 0.5 , 11.3 VA maximum (SNAP-PAC-S1 controllers with serial numbers below 500,000 use 8–24 VDC)
Operating temperature Storage temperature Humidity	-20 °C to 60 °C -40 °C to 85 °C 0% to 95% relative humidity, non-condensing

Software PAC Project Basic	Includes programming, HMI software, and configuration software; included with purchase of controller. PAC Project Professional PAC Project Basic plus OPC 2.0-compliant OPC server, OptoControl strategy and OptoDisplay project importing, support for serial <i>mistic</i> I/O units, and Ethernet link redundancy support. Use HTTPS to access data (read/write or read-only) from controller tags using your chosen programming language. Data returned in JSON. More information at developer.opto22.com
PAC Project Professional	
RESTful API*	
Number of charts that can run simultaneously	32
Other features	Multiple protocol support including TCP/IP, HTTP/HTTPS, FTP, SNMP v2.0c (with firmware 8.2a), Modbus/TCP, EtherNet/IP™, and OptoMMP™ Real-time clock FTP server/client with file system (in RAM and in removable storage) Ethernet link redundancy or network segmenting
Agency certifications	(-FM models only) Factory Mutual approved All models: CE, RoHS, DFARS; UKCA
Warranty	30 months from date of manufacture

* Requires firmware R9.5a or higher

SYSTEM ARCHITECTURE

SNAP-PAC-S1 Controller and Serial-based I/O Units

The network shown in this diagram requires PAC Control Professional and PAC Display Professional.

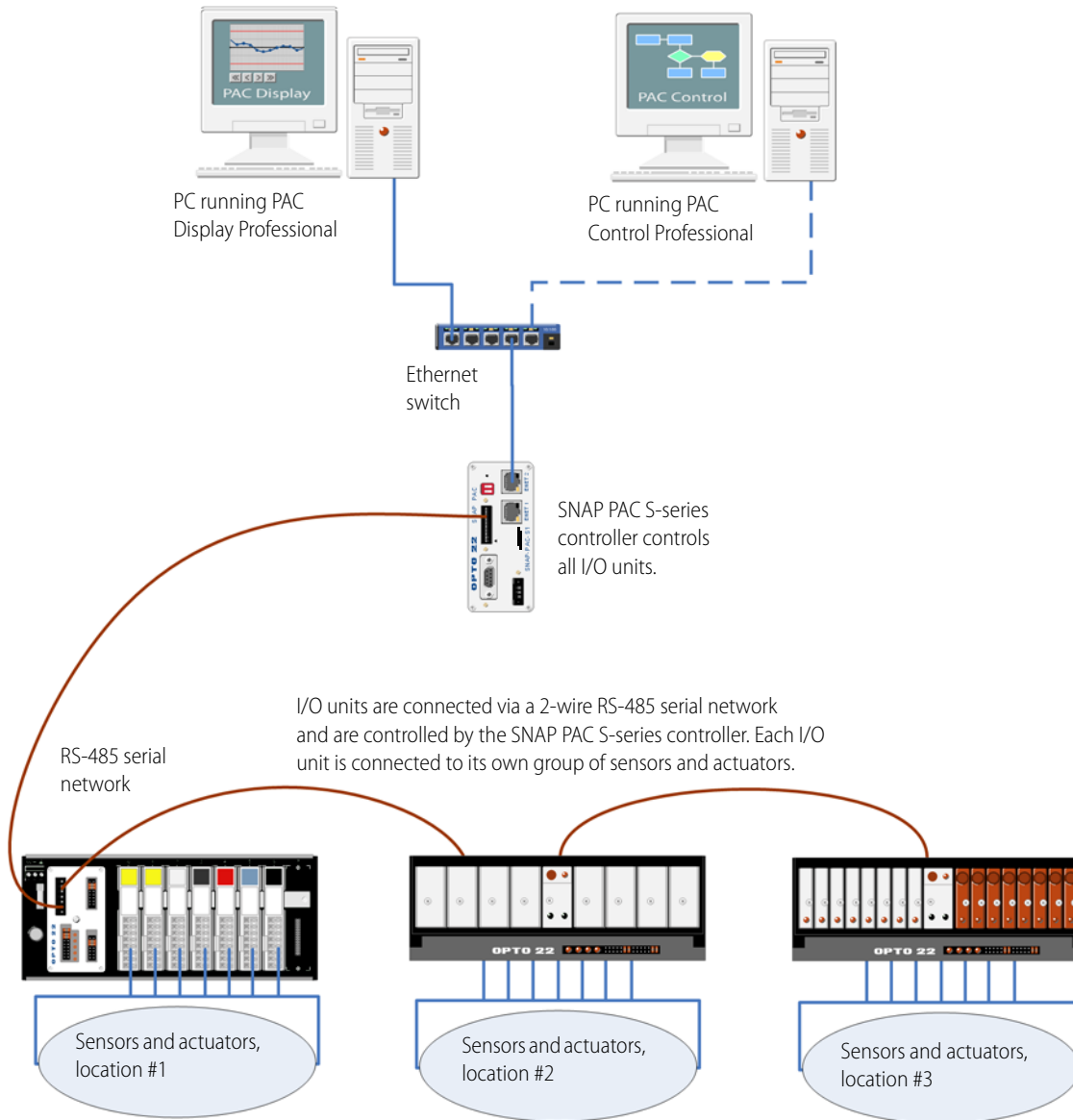

This diagram shows a SNAP PAC S-series controller connected to multiple Opto 22 serial-based I/O units over an RS-485 serial network. The controller is also connected to a larger, separate enterprise Ethernet network to provide process data to a PC running Opto 22's PAC Display HMI software.

The diagram also shows a PC running PAC Control Professional; the control program (or *strategy*) that runs on the SNAP controller was developed in this application. Once developed, the strategy is downloaded to the controller and runs independently.

SYSTEM ARCHITECTURE (CONTINUED)

SNAP-PAC-S2 Controller and Serial-based I/O Units

The network shown in this diagram requires PAC Control Professional and PAC Display Professional.

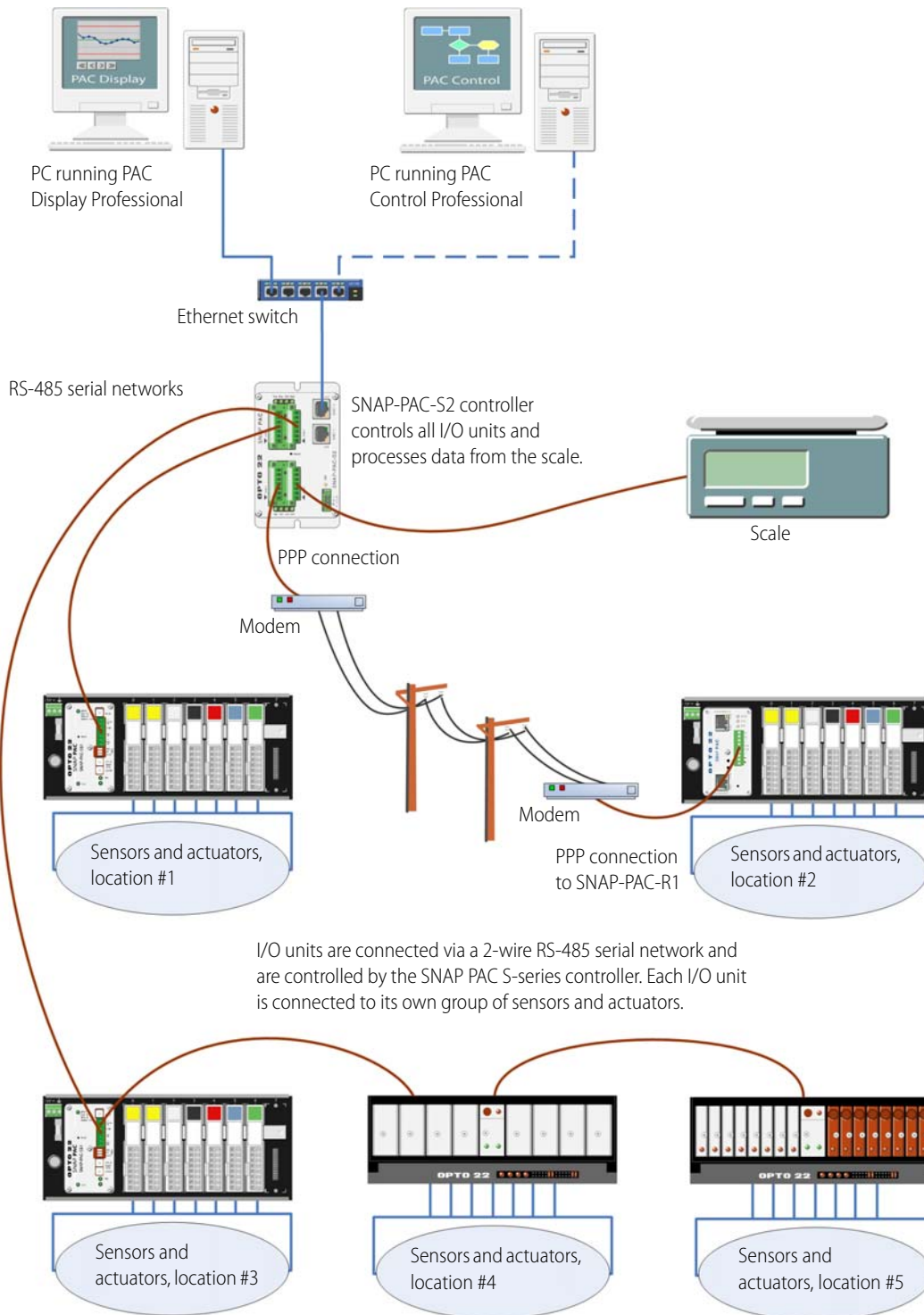

SYSTEM ARCHITECTURE (CONTINUED)

SNAP PAC S-series Controller Isolating Ethernet Networks into Zones

The network shown in this diagram requires PAC Control Professional and PAC Display Professional.

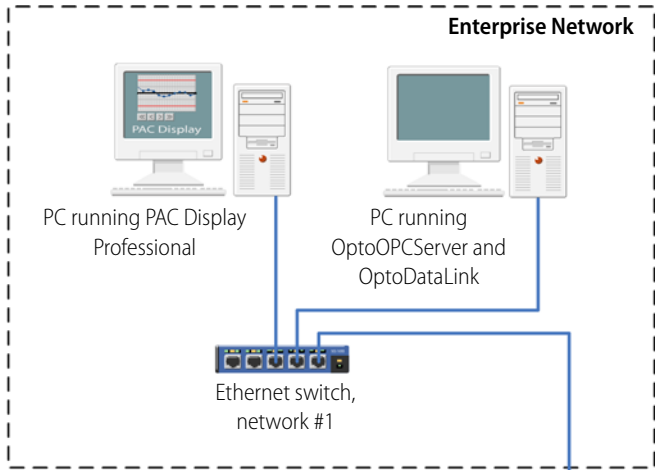

This diagram shows multiple Opto 22 SNAP I/O units connected together over an Ethernet network and controlled by a SNAP PAC S-series controller running a control strategy. The controller is also connected to a larger, separate enterprise Ethernet network to provide data to two PCs running Opto 22's PAC Display HMI software and OptoOPCServer.

Sitting between the two networks, the SNAP PAC S-series controller isolates I/O and control traffic on the trusted network from the untrusted enterprise network, and vice versa.

For this system, PAC Display must be configured to access the I/O through the controller rather than directly from the I/O units, since they are on a separate network.

SNAP PAC S-series controller communicates with host computers through one network interface and controls I/O with other devices through the other interface, isolating trusted and untrusted networks into zones.

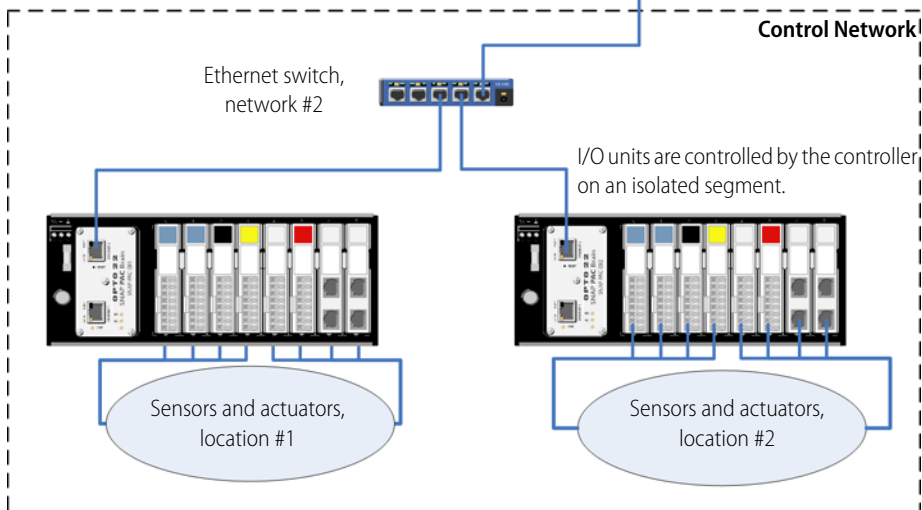

SYSTEM ARCHITECTURE (CONTINUED)

SNAP PAC S-Series Controller in Redundant Network Configuration

The network shown in this diagram requires PAC Control Professional and PAC Display Professional.

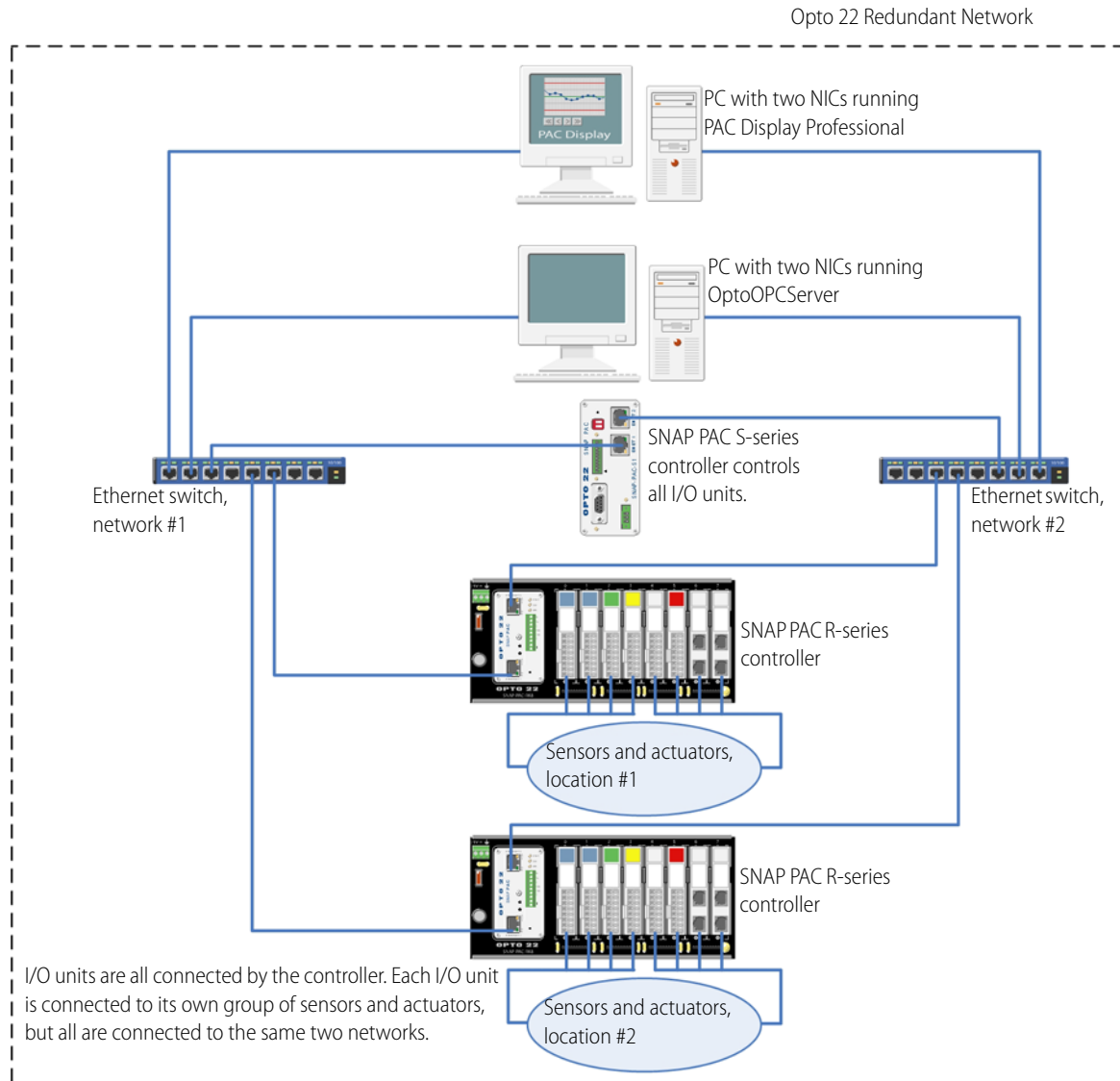

This diagram shows a SNAP PAC S-series controller connected to two separate Ethernet networks. This configuration addresses the concern that an Ethernet network may fail or need maintenance, leaving the PC running OptoOPCServer, the PC running PAC Display, the controller, and the I/O units unable to communicate.

In this configuration, if one network goes down, devices can still communicate on the other. Each PC has two network interface cards (NICs), and the SNAP PAC S-series controller and the I/O units (SNAP PAC R-series) have two network interfaces as well.

SYSTEM ARCHITECTURE (CONTINUED)

SNAP PAC S-series Redundant Controllers

Controller redundancy requires PAC Project Professional 9.0 or newer.

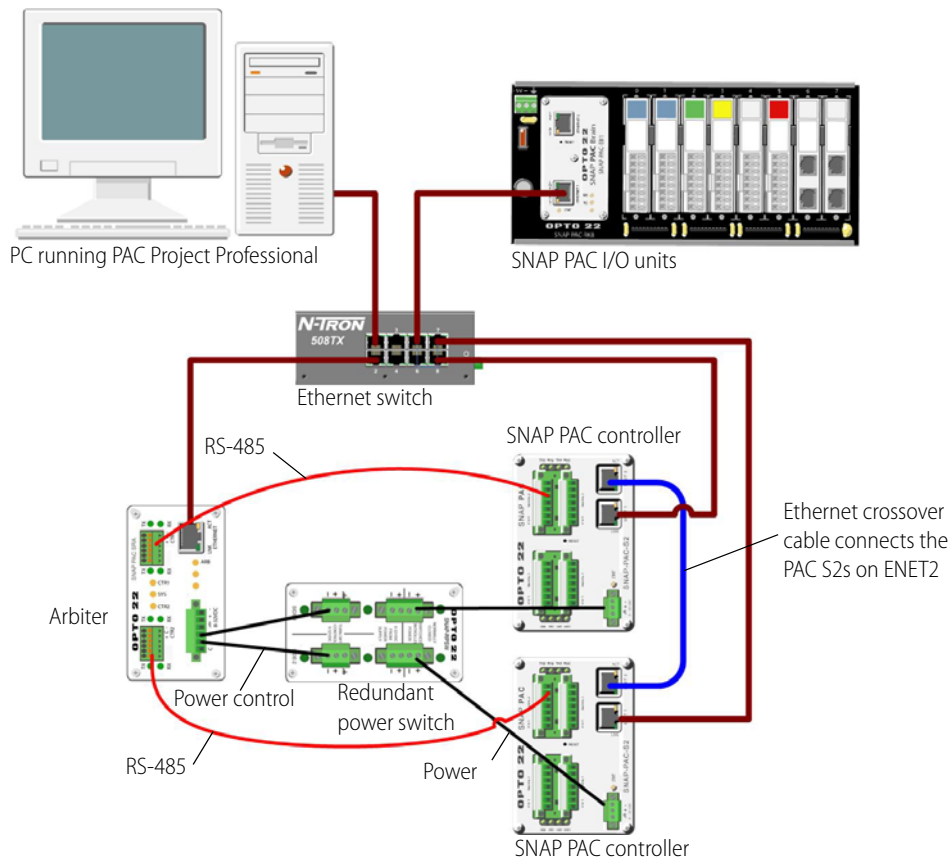

In this diagram, two S-series controllers are operating redundantly. One is the active controller, while the other acts as a backup, ready to take over should the first one fail.

Controller redundancy requires PAC Project Professional 9.0 or newer and the Redundancy Option Kit, which includes the arbiter and the redundant power switch in this diagram. PAC Redundancy Manager, a software utility for setting up and maintaining the system, is included in PAC Project Pro.

The two controllers you use must be exactly the same part number (for example, two SNAP-PAC-S2 controllers or two SNAP-PAC-S1-FM controllers).

One advantage of an Opto 22 redundant system is that it uses standard PACs, standard cabling, and standard I/O. Another advantage is that either controller can act as the active or backup controller; you can switch their roles at any time for maintenance, for example.

For detailed information on redundancy, see form 1831, [SNAP PAC System Redundancy User's Guide](#).

SNAP-PAC-S1 CONNECTORS AND INDICATORS

This diagram applies to both the SNAP-PAC-S1 and the SNAP-PAC-S1-FM.

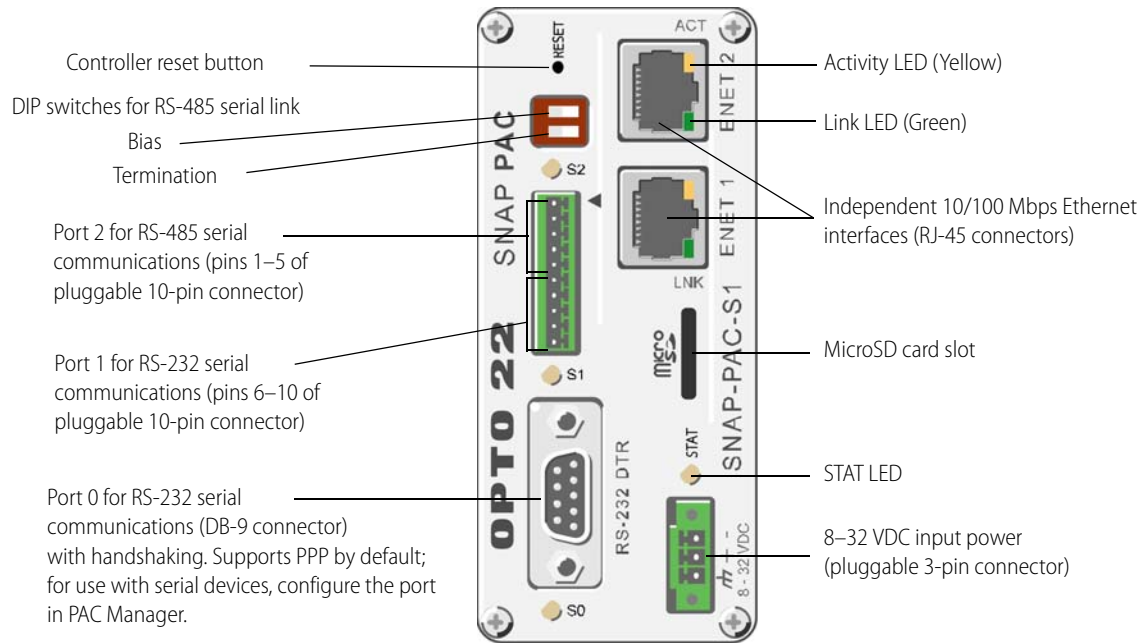

Status and Activity LEDs

Indicator	Description
S0	RS-232 serial activity on port 0
S1	RS-232 serial activity on port 1
S2	RS-485 serial activity
STAT	Startup status and control program operational status
ACT	Ethernet network activity
LINK	Link established with Ethernet network

Port 0 for RS-232 serial (DB-9 connector)

Pin	Description	Signal Direction
1	DCD	In
2	RX	In
3	TX	Out
4	DTR	Out
5	COM	
6	DSR	In
7	RTS	Out
8	CTS	In
9	RI*	In

* RI signal does not occur on PACs with a microSD card slot

Ports 1 and 2 for RS-485 and RS-232 serial

	Pin	Description	Signal Direction
Port 2 for RS-485 serial (2-Wire)	1	TX/RX+	In/Out
	2	TX/RX-	In/Out
	3	SIG COM*	
	4	IRQ+	In
	5	IRQ-	In
Port 1 for RS-232 serial	6	TX	Out
	7	RX	In
	8	GND	
	9	RTS	Out
	10	CTS	In

* Isolated ground

SNAP-PAC-S2 CONNECTORS AND INDICATORS

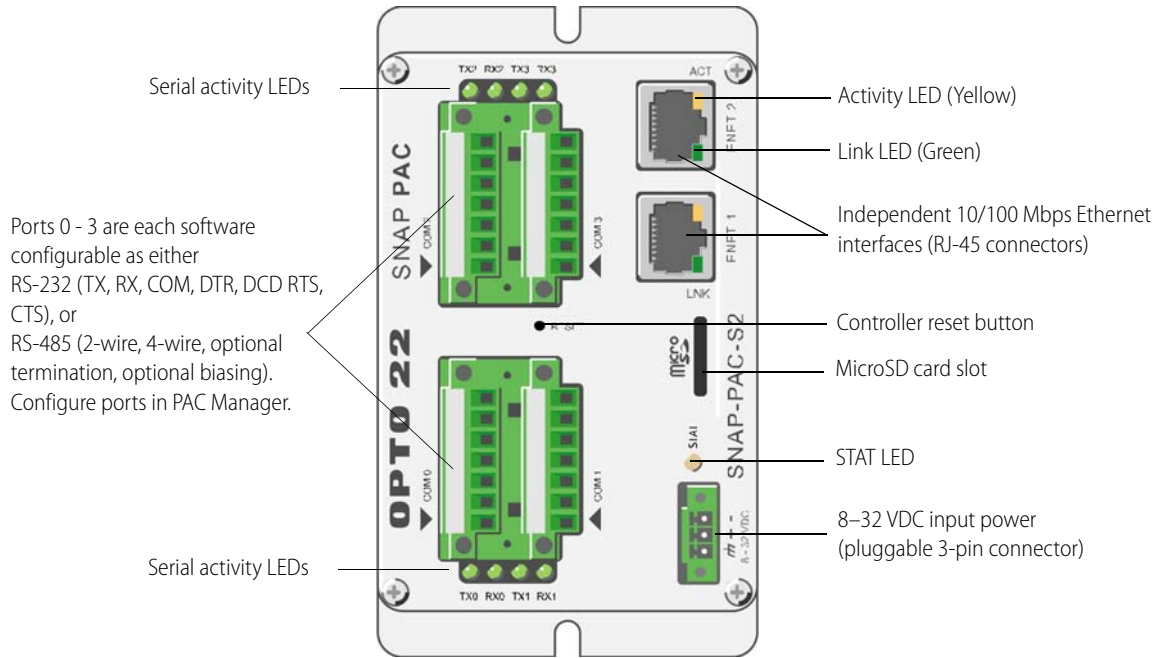

RS-485 and RS-232 Ports¹

Pin	RS-232	Signal Direction	RS-485	Signal Direction
1	TX	Out	TX/RX+	In/Out
2	RX	In	TX/RX-	In/Out
3	COM ²		COM ²	
4	RTS	Out	RX+ (4 wire)	In
5	CTS	In	RX- (4 wire)	In
6	DTR	Out	IRQ+	In
7	DCD	In	IRQ-	In

¹ **CAUTION: Do not use communication port connectors from a legacy OptoControl controller***. Legacy connectors will fit in a SNAP-PAC-S2, but the pin orientation is different. Instead, use the connectors supplied with the SNAP-PAC-S2 controller.

² Isolated ground. (Each channel is isolated from the others.)

*Legacy OptoControl Controllers:

G4LC32	G4LC32ISA-LT	M4RTU
G4LC32SX	M4	SNAP-LCM4
G4LC32ISA	M4IO	SNAP-LCSX/PLUS

Status and Activity LEDs

Indicator	Description
TX0/RX0	Serial activity on port 0
TX1/RX1	Serial activity on port 1
TX2/RX2	Serial activity on port 2
TX3/RX3	Serial activity on port 3
STAT	Startup status and control program operational status
ACT	Ethernet network activity
LINK	Link established with Ethernet network

DIMENSIONAL DRAWINGS

SNAP-PAC-S1 and SNAP-PAC-S1-FM Panel Mounting and Dimensions

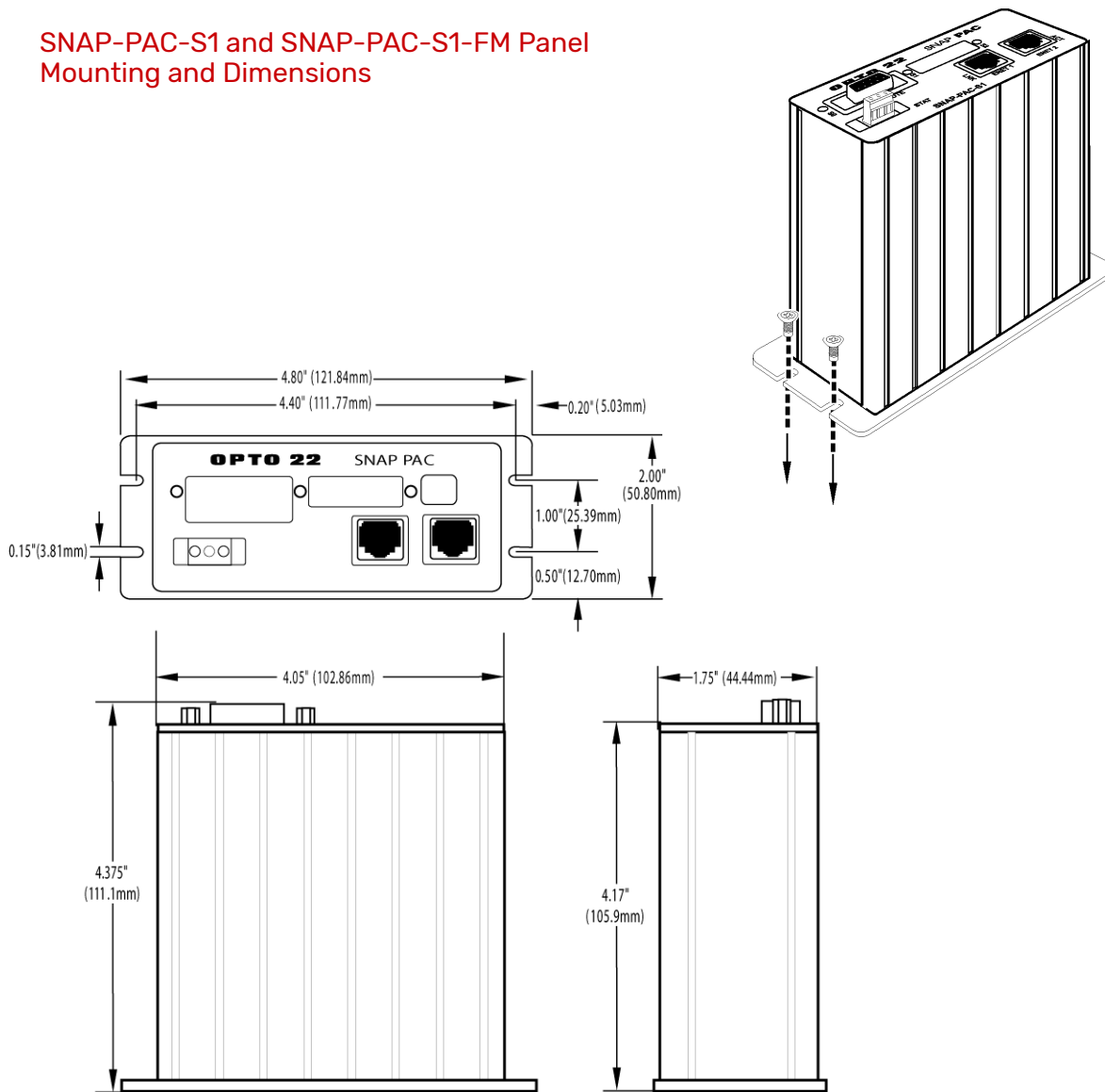

DIMENSIONAL DRAWINGS (CONTINUED)

SNAP-PAC-S1 and SNAP-PAC-S1-FM DIN-Rail Mounting and Dimensions

Requires a [SNAP-PSDIN](#) adapter (purchased separately).

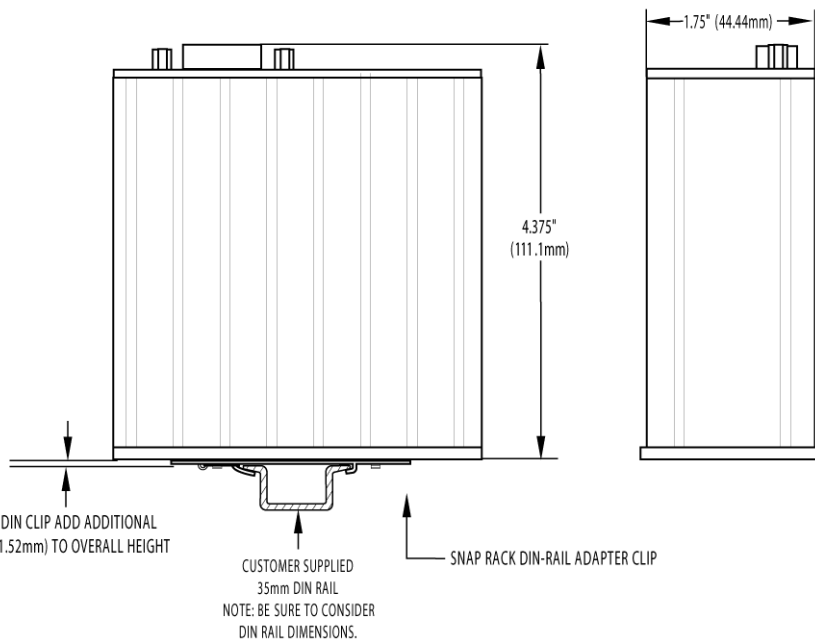
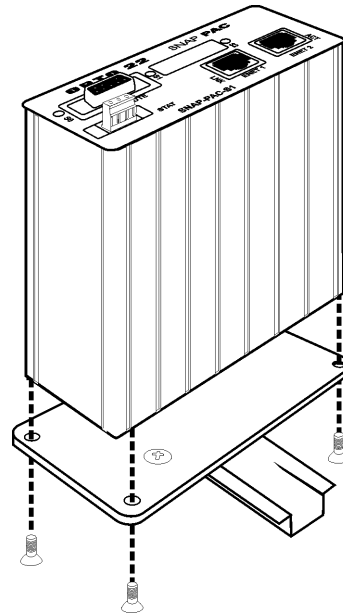
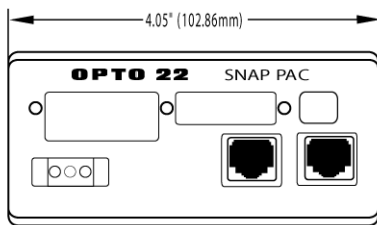

DIMENSIONAL DRAWINGS (CONTINUED)

SNAP-PAC-S2 Panel Mounting and Dimensions

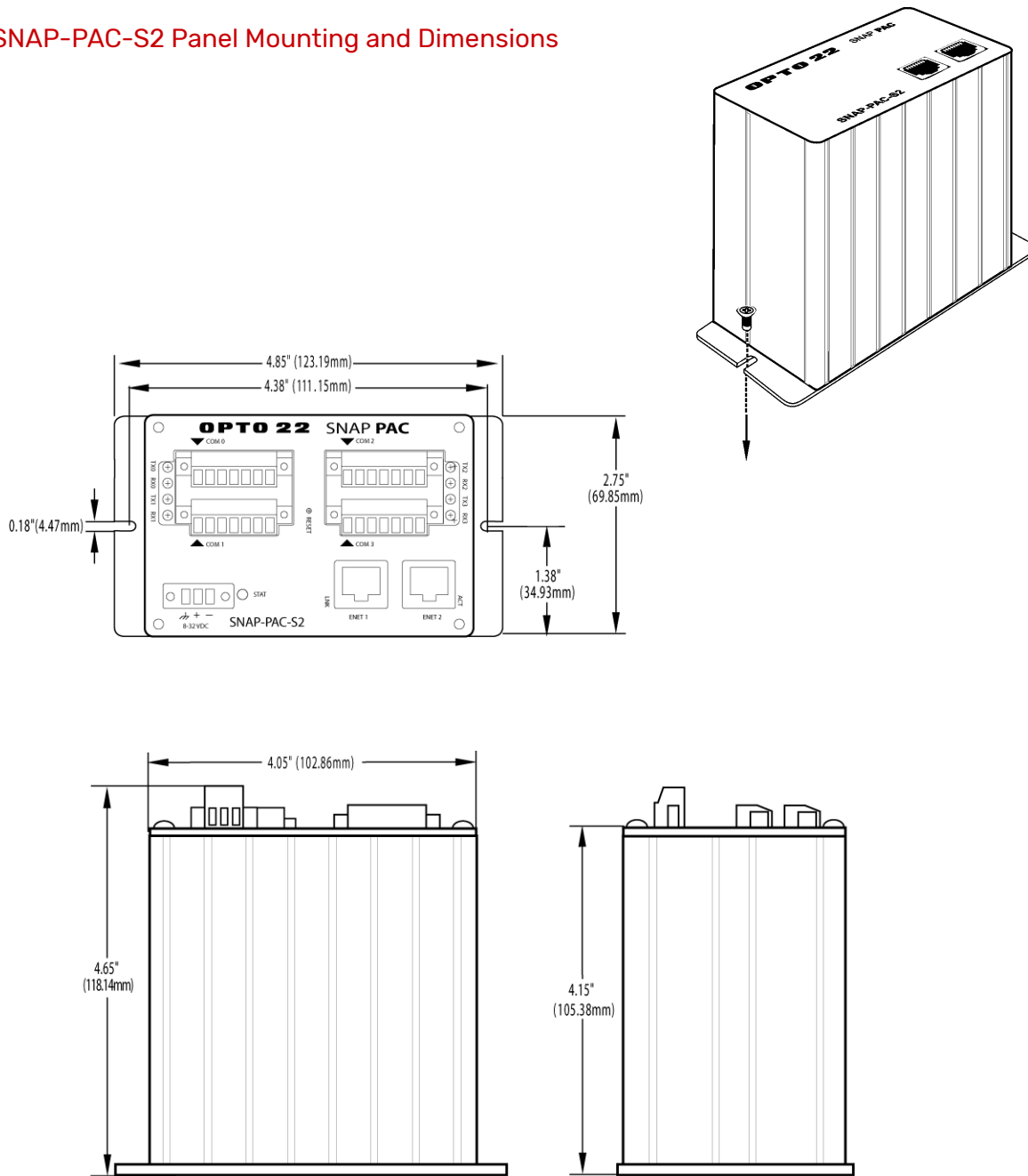

DIMENSIONAL DRAWINGS (CONTINUED)

SNAP-PAC-S2 DIN-Rail Mounting and Dimensions

Requires a [SNAP-S2DIN](#) adapter (purchased separately).

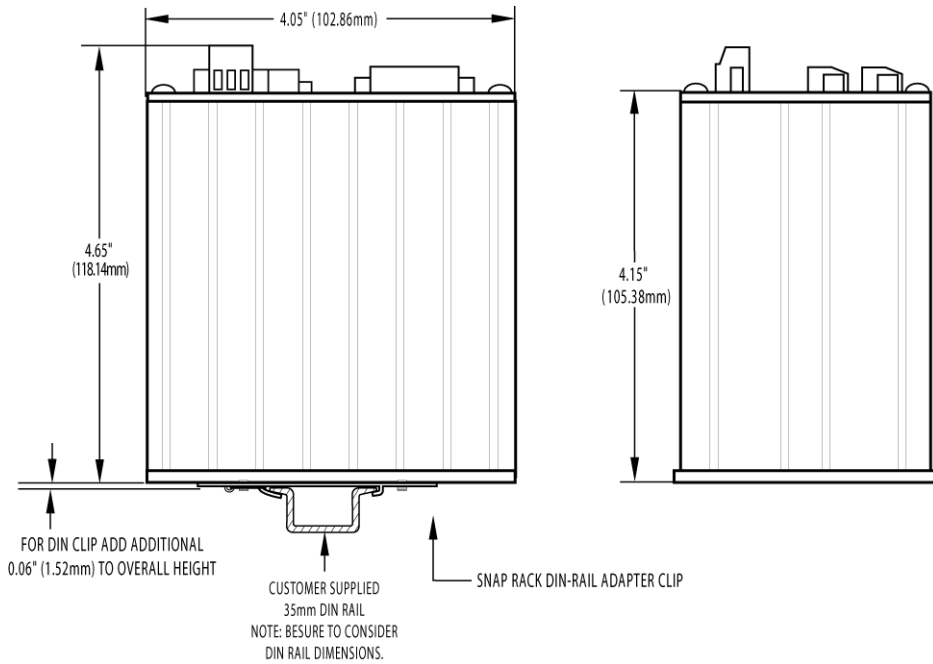
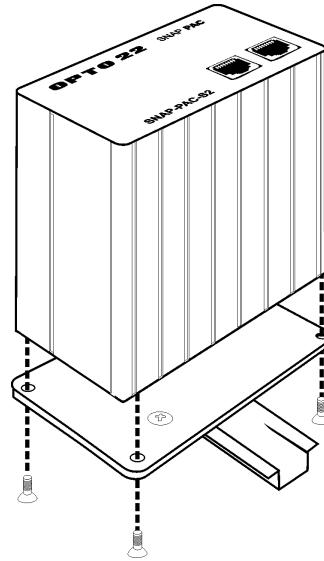
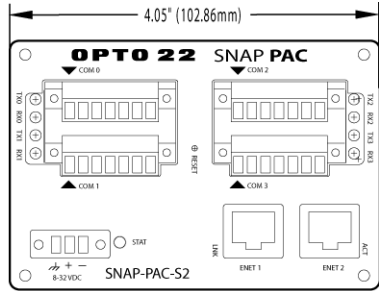

PRODUCTS

Opto 22 develops and manufactures reliable, easy-to-use, open standards-based hardware and software products. Industrial automation, process control, remote monitoring, data acquisition, and industrial internet of things (IIoT) applications worldwide all rely on Opto 22.

groov RIO®

groov RIO edge I/O offers a single, compact, PoE-powered industrial package with web-based configuration and IIoT software built in, support for multiple OT and IT protocols, and security features like a device firewall, data encryption, and user account control.

Standing alone, groov RIO connects to sensors, equipment, and legacy systems, collecting and securely publishing data from field to cloud. Choose a universal I/O model with thousands of possible field I/O configurations, with or without Ignition from Inductive Automation®, or a RIO EMU energy monitoring unit that reports 64 energy data values from 3-phase loads up to 600 VAC, Delta or Wye.

You can also use groov RIO with a Modbus/TCP master or as remote I/O for a groov EPIC system.

groov EPIC® System

Opto 22's groov Edge Programmable Industrial Controller (EPIC) system gives you industrially hardened control with a flexible Linux®-based processor with gateway functions, guaranteed-for-life I/O, and software for your automation and IIoT applications.

groov EPIC Processor

The heart of the system is the groov EPIC processor. It handles a wide range of digital, analog, and serial functions for data collection, remote monitoring, process control, and discrete and hybrid manufacturing.

In addition, the EPIC provides secure data communications among physical assets, control systems, software applications, and online services, both on premises and in the cloud. No industrial PC needed.

Configuring and troubleshooting I/O and networking is easier with the EPIC's integrated high-resolution color touchscreen. Authorized users can manage the system locally on the touchscreen, on a monitor connected via the HDMI or USB ports, or on a PC or mobile device with a web browser.

groov EPIC I/O

groov I/O connects locally to sensors and equipment. Modules have a spring-clamp terminal strip, integrated wireway, swing-away cover, and LEDs indicating module health and discrete channel status. groov I/O is hot swappable, UL Hazardous Locations approved, and ATEX compliant.

groov EPIC Software

The groov EPIC processor comes ready to run the software you need:

- Programming: Choose flowchart-based PAC Control, CODESYS Development System for IEC61131-3 compliant programs, or secure shell access (SSH) to the Linux OS for custom applications
- Node-RED for creating simple IIoT logic flows from pre-built nodes
- Efficient MQTT data communications with string or Sparkplug data formats
- HMI: groov View to build your own HMI viewable on touchscreen, PCs, and mobile devices; PAC Display for a Windows HMI; Node-RED dashboard UI
- Ignition or Ignition Edge® from Inductive Automation (requires license purchase) with OPC-UA drivers to Allen-Bradley®, Siemens®, and other control systems, and MQTT communications



Older products

From solid state relays, to world-famous G4 and SNAP I/O, to SNAP PAC controllers, older Opto 22 products are still supported and working hard at thousands of installations worldwide. You can count on us for the reliability and service you expect, now and in the future.

QUALITY

Founded in 1974, Opto 22 has established a worldwide reputation for high-quality products. All are made in the U.S.A. at our manufacturing facility in Temecula, California.

Because we test each product twice before it leaves our factory rather than testing a sample of each batch, we can afford to guarantee most solid-state relays and optically isolated I/O modules for life.

FREE PRODUCT SUPPORT

Opto 22's California-based Product Support Group offers free technical support for Opto 22 products from engineers with decades of training and experience. Support is available in English and Spanish by phone or email, Monday–Friday, 7 a.m. to 5 p.m. PST.

Support is always available on our website, including [free online training](#) at OptoU, how-to [videos](#), [user's guides](#), the Opto 22 KnowledgeBase, and [OptoForums](#).

PURCHASING OPTO 22 PRODUCTS

Opto 22 products are sold directly and through a worldwide network of distributors, partners, and system integrators. For more information, contact Opto 22 headquarters at **800-321-6786** (toll-free in the U.S. and Canada) or **+1-951-695-3000**, or visit our website at www.opto22.com.