

# Related Equipment: Heavy Duty Auto Drain Series ADH4000



## Easy maintenance

Can maintain without removing the existing piping.

## No need for electric power and no waste of air.

Float type auto drain allows automatic drain discharge without electric power.

## Mounting example

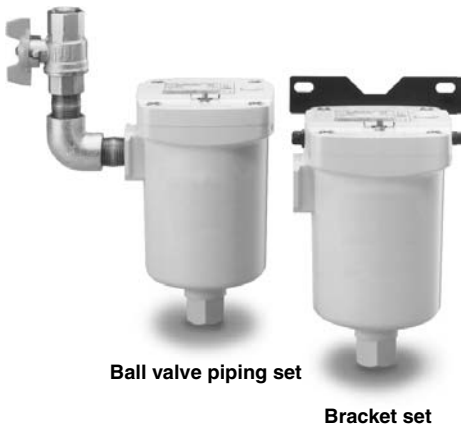
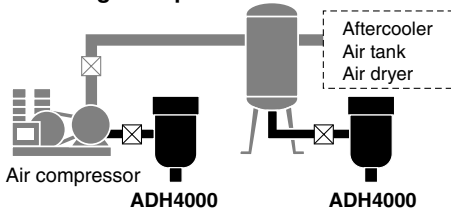

JIS Symbol

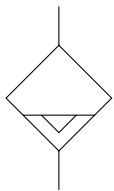

## Specifications

Auto drain type	Float type
Auto drain valve type	N.O. (Normally open: Open in the case of pressure loss)
Proof pressure	2.5 MPa
Max. operating pressure	1.6 MPa
Operating pressure range <sup>Note)</sup>	0.05 to 1.6 MPa
Fluid	Compressed air
Ambient and fluid temperature	5 to 60°C (With no condensation) <Corrosive gas, flammable gas and organic solvents are not allowed.>
Max. drain discharge	400 cc/min (Pressure 0.7 MPa, in the case of water)
Mass	1.2 kg (With bracket: 1.3 kg)
Paint color	White

Note) Use for an air compressor with flow more than 50 ℓ/min (ANR).

## Accessory (Option)

Description	Part no.	Contents
Bracket set	BM58	Bracket ..... 1 pc. M6 x 10 ℓ (Hexagon socket head cap screw) ... 2 pcs.
Ball valve piping set	ADH-C400	Ball valve/Rc 1/2 ..... 1 pc. Barrel nipple/R 1/2 ..... 2 pcs. Elbow/Rc 1/2 ..... 1 pc.

Note) Accessory (Option) is included, but not assembled.

## How to Order

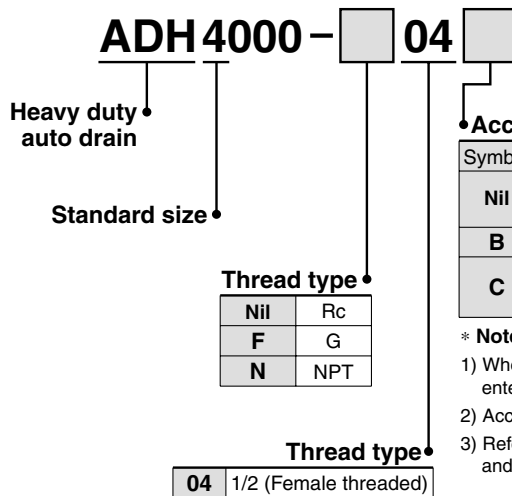

\* Accessory (Option)\*

Symbol	Contents	Note
Nil	None (Standard)	—
B	Bracket set	—
C	Ball valve piping set	Not available for G/NPT threads.

- \* Notes
- 1) When more than one option is desired, enter in alphabetical order.
  - 2) Accessory is not assembled.
  - 3) Refer to each drawing of dimensions and mounting methods for details.

## Construction

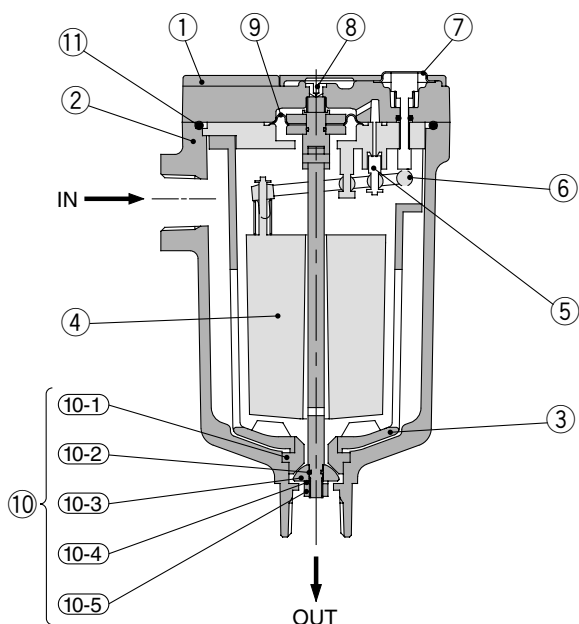

### Component Parts

No.	Description	Material	Note
1	Body	Aluminum alloy	Baking finish
2	Housing	Aluminum alloy	Baking finish
3	Drain guard	Aluminum alloy	Baking finish
4	Float	Foam rubber	
5	Pilot valve	Stainless steel + Rubber	
6	Lever	Resin	
7	Flushing button	Brass	
8	Orifice		
9	Diaphragm	Rubber	

### Replacement Parts

No.	Description	Part no.	Note
10	Repair kit for main valve	ADH-D400	Kit includes parts from (10-1) to (10-5)
11	O-ring	G85(B)	Material: NBR

Note) When changing parts, follow the operating manual.  
Do not disassemble other parts.

## ⚠ Specific Product Precautions

Be sure to read before handling.

Refer to front matters 42 and 43 for Safety Instructions and pages 6 to 8 for Air Preparation Equipment Precautions.

### Design

#### ⚠ Caution

- Use this product in an area where the air pressure does not exceed 1.6 MPa.  
If exceeding 1.6 MPa, it could lead to an accident or malfunction.
- An air pressure of 0.05 MPa and an air compressor's discharge flow rates higher than 50 l/min (ANR) are required.  
Below these values, the air will be exhausted continuously from the drain exhaust port.
- Keep the compressed air and the ambient temperature of the location where this product is installed within the range of 5 to 60°C. Exceeding this range could lead to a failure or malfunction.
- Avoid using this product in an area where corrosive gases, flammable gases or organic solvents are contained in the compressed air or in the surrounding air.

### Selection

#### ⚠ Caution

- The maximum dischargeable drainage rate is 400 cc/min.  
If using this product in excess of this value, there could be causing the drain to flow over to the outlet side.

### Piping

#### ⚠ Caution

- Use piping of 1/2<sup>B</sup> or larger for drain inlet and avoid riser piping.
- For drain piping, use a pipe whose I.D. is not less than 8 mm and length not more than 10 m. Do not make any upward angles in drain line. Be sure to secure exhaust port piping since drain is under pressure.

### Mounting

#### ⚠ Caution

- Install with "out port" down in a vertical position.  
Inclination from the vertical line should be less than 5°.
- Install with at least 200 mm of free space above the unit to allow for maintenance.
- To place this product near the air compressor, install in such a way that the vibrations will not be transmitted.
- Install a valve to drain inlet so that maintenance is possible.  
Use a ball valve with a bore size of more than 15 mm. (Ball valve piping set is available as an accessory (option).)

### Mounting

#### ⚠ Caution

- When not draining sufficiently, open the bleed valve so that drain could run through easily.

### Maintenance

#### ⚠ Caution

- Check drain condition periodically (more than once a day).  
Also, push the flushing button to open the exhaust valve.
- Pilot air is exhausted from the exhaust port indicated in "Dimensions". Do not cover this exhaust port. Clean the exhaust port so that port is not blocked by dust, etc.
- When solid foreign objects exceeding 1 mm come in, the main valve may become blocked. After recovering the internal pressure of this product to 0 MPa (atmospheric pressure), remove the hexagon socket head cap screw (M6) from the body part and wash inside with water to remove foreign solid objects blocking the main valve.
- When using this product, drain may not easily enter the product. In such a case, adjust the open angle of its bleed valve to lower the pressure a bit inside the bowl so that drain could run through easily.

HAA  
HAW

AT

IDF  
IDU

IDFA

IDFB

ID

IDG

AMG

AFF

AM

AMD

AMH

AME

AMF

SF

SFD

LLB

AD

GD

# Series ADH4000

## Dimensions

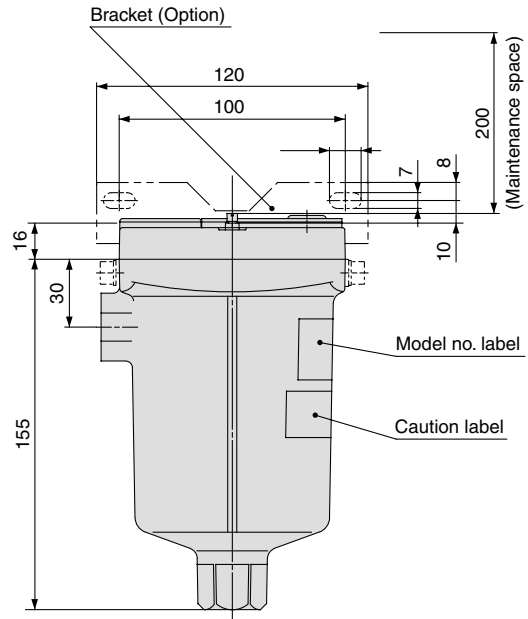
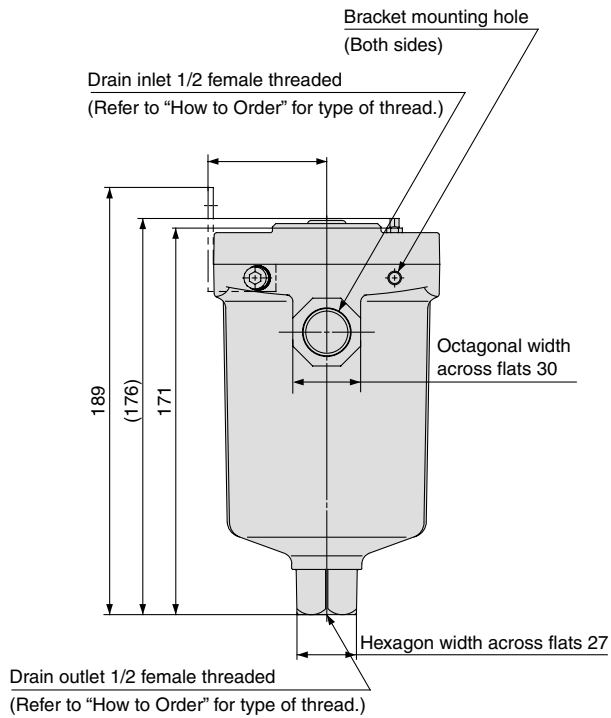
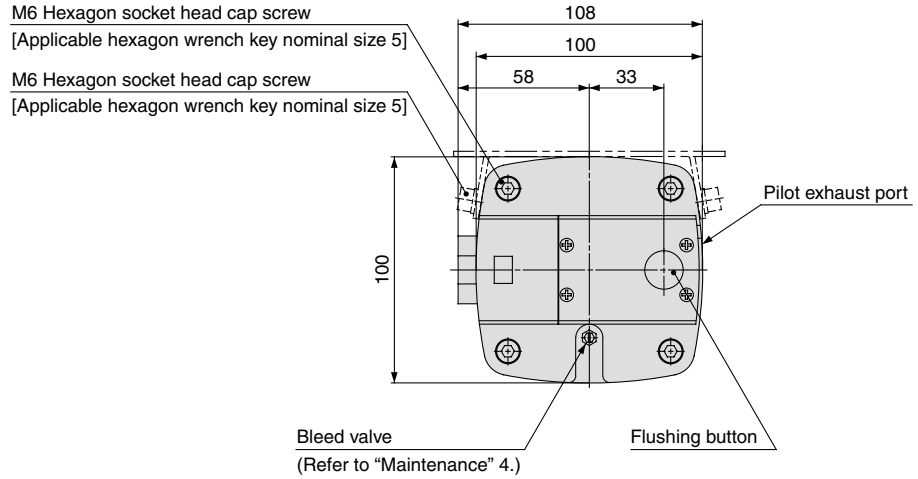

### Option: Reference Figure of Assembly

