

# Inch-size Rectangular Multi-connector Series *KDM*

No. of Connecting Tubes: 10, 20

**Multi-connector is effective in saving labor for separate transportation of the panel and the machine, and for exchanging units due to failure.**

### Substantial reduction in mounting space

In comparison with a model requiring many union joints for panels and partitions, this model needs only a small space.

### One-touch connection/disconnection of connector

Multiple pipes can be connected/disconnected in one-touch operation without connection error. Thus man-hours for connection/disconnection are cut down substantially.

### One-touch tube connection

One-touch fittings substantially cuts down man-hours for piping.

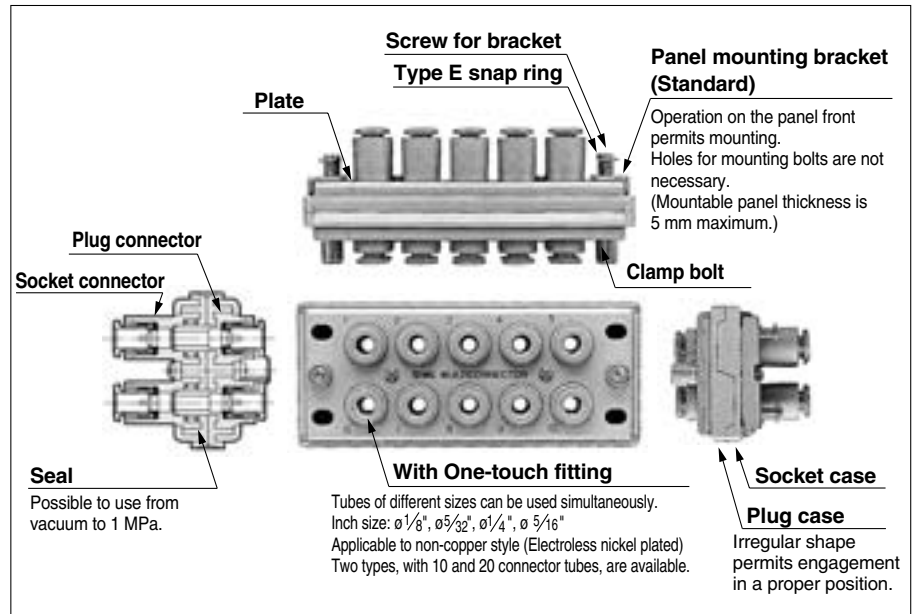
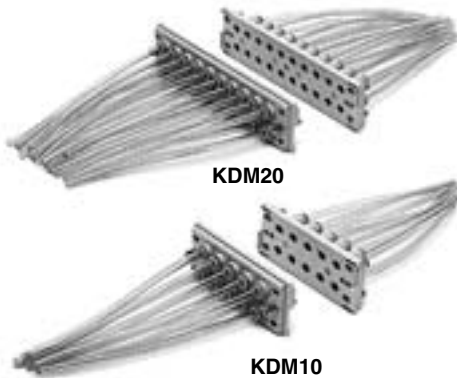

### Model

No. of connecting tubes	Tubing O.D.	Model	Weight (g)	Color of release button
10	$\phi 1/8"$	<b>KDM10-01</b>	300	Red
	$\phi 5/32"$	<b>KDM10-03</b>		
	$\phi 1/4"$	<b>KDM10-07</b>		
20	$\phi 5/16"$	<b>KDM10-09</b>	520	
	$\phi 1/8"$	<b>KDM20-01</b>	520	
	$\phi 5/32"$	<b>KDM20-03</b>		
	$\phi 1/4"$	<b>KDM20-07</b>		
	$\phi 5/16"$	<b>KDM20-09</b>	950	

### Applicable Tubing

Tubing material	FEP, PFA, Nylon, Soft nylon, Polyurethane
Tubing O.D.	$\phi 1/8"$ , $\phi 5/32"$ , $\phi 1/4"$ , $\phi 5/16"$

### Specifications

Fluid	Air
Operating pressure range <sup>Note)</sup>	-100 kPa to 1 MPa
Proof pressure	1.5 MPa
Ambient and fluid temperature	-5 to 60°C (No freezing)

Note) Please avoid using in a vacuum holding application such as a leak tester, since there is leakage.

 **Made to Order**  
(Refer to page 201 for details.)

## Principal Parts Material

Plug case, Socket case		POM
Plate, Bracket		SPCC plated
Plug connector, Socket connector	Body	PBT, C3604BD Electroless nickel plated (ø5/16)
	Chuck	Stainless steel 304
	Guide	Stainless steel 304, C3604BD Electroless nickel plated, POM (ø5/16)
	Collet, Release button	POM
	Seal	NBR
Clamp bolt, Screw for bracket, Cross-recessed head machine screw		SWRM (Nickel plated)
Type E snap ring		Stainless steel 304

## Model

No. of connection tubes	Tubing O.D.	Model		Color of release button
		Plug	Socket	
10	ø 1/8"	KDM10P-01	KDM10S-01	Red
	ø 5/32"	KDM10P-03	KDM10S-03	
	ø 1/4"	KDM10P-07	KDM10S-07	
	ø 5/16"	KDM10P-09	KDM10S-09	
20	ø 1/8"	KDM20P-01	KDM20S-01	
	ø 5/32"	KDM20P-03	KDM20S-03	
	ø 1/4"	KDM20P-07	KDM20S-07	
	ø 5/16"	KDM20P-09	KDM20S-09	

## Mixed Sizes of Plug Connectors and Socket Connectors

The rectangular multi-connector permits connector exchange in any desired position, thus allowing use of different sizes of tubes.

## Model

Connector	Tubing O.D.	Model	Color of release button
Plug connector	ø 1/8"	KDMP-01	Red
	ø 5/32"	KDMP-03	
	ø 1/4"	KDMP-07	
	ø 5/16"	KDMP-09	
Socket connector (with seal)	ø 1/8"	KDMS-01	
	ø 5/32"	KDMS-03	
	ø 1/4"	KDMS-07	
	ø 5/16"	KDMS-09	

1. Loosen the cross-recessed head machine screw by using a Phillips screwdriver to remove the plate from the case.

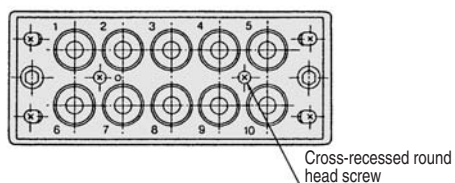

2. After exchanging connectors in desired places, fix the plate to the case by using a Phillips screwdriver.

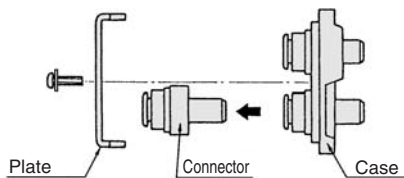

## How to Use

### ⚠ Caution

#### Separation

Loosen the clamp bolt to separate the plug side from the socket side.

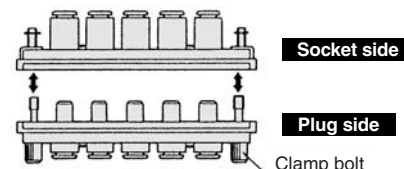

#### Connection

Put together the irregular faces for engagement and connect the plug case to the socket. After tightening the clamp bolt by hand, tighten it further with allen wrench (nominal width across flats: 4).

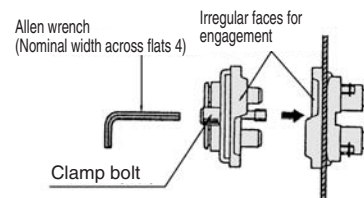

#### Panel mounting

1. Loosen (4) screws for bracket on the socket side using a Phillips screwdriver (JIS nominal No. 2) until the bracket touches the stop ring.

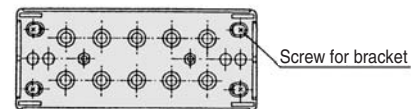

2. Shift the panel mounting bracket to the inside (Move the screw for bracket in the longitudinal direction of the slot) and put the connector in the panel mounting hole. (Panel-mounting hole: See Dimensions.)

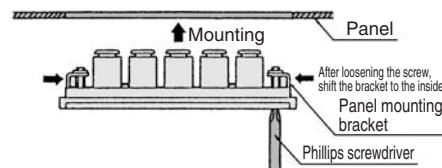

3. After shifting the bolt for bracket to the outside, tighten the bolt by a Phillips screwdriver to fix the socket case.

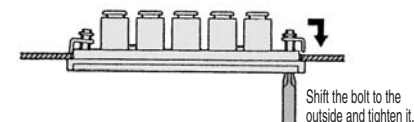

4. Loosen the screw for bracket until the bracket touches the stop ring and shift the bracket to the inside to remove the connector from the panel.

- K
- M
- H
- KK
- D
- MS
- LQ
- MQR
- T

# Series KDM



## Dimensions

### KDM10

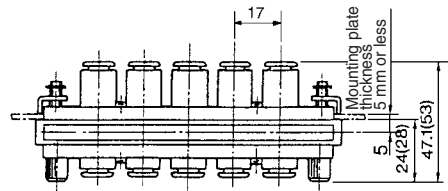

( ): Dimensions for KDM10-09

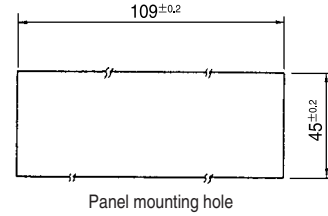
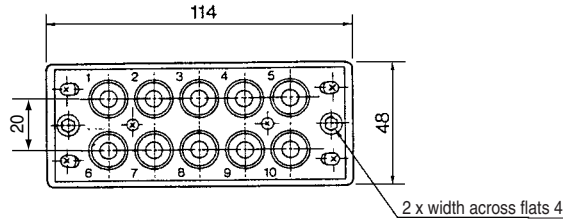

### KDM20

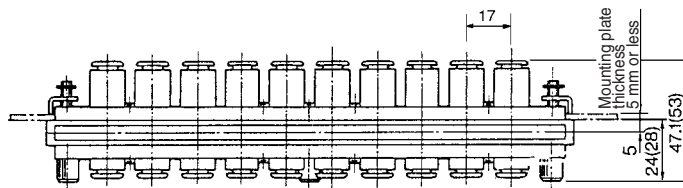

( ): Dimensions for KDM20-09

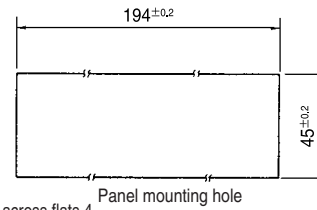
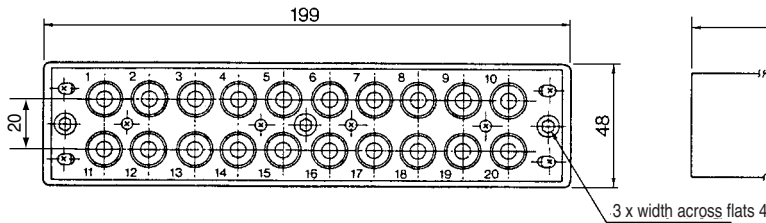

## Handling of One-touch Fittings

### ⚠ Caution

Refer to "Fittings & Tubing Precautions" for the details of installation/removal of One-touch fittings on the page 15.



Please contact SMC for detailed dimensions, specifications, and delivery.

## 1 Grease-free Specifications

Symbol	Specifications
<b>X17</b>	Grease-free Rubber material: NBR (With fluorine coating) Release button color: Light blue
<b>X39</b>	Grease-free Rubber material: NBR (With fluorine coating) Release button color: Light blue Clean (Copper-free, air blow, double package)

Suffix "-X17" to the end of part number.

Example) **KDM10-03-X17**

## 2 Other Specifications

Symbol	Specifications
<b>X12</b>	Lubricant: White Vaseline Release button color: White

## 3 Mixed Tubing Size Type

### ■ Mixed Tubing Size Type

Mixed tubing size manifolds are available to meet your individual requirements. Please consult with SMC for availability.

- K**
- M**
- H**
- KK**
- D**
- MS**
- LQ**
- MQR**
- T**