

3 Port Solenoid Valve Series VQ100

Unprecedented high speed, stable response, and extra-long service life.

ON: 3.5ms, OFF: 2ms, Dispersion accuracy ± 1 ms
(With indicator light and surge voltage suppressor;
supply pressure 0.5MPa)
200million cycles or more (clean and dry air)
(Factors determined in a life test
by SMC)

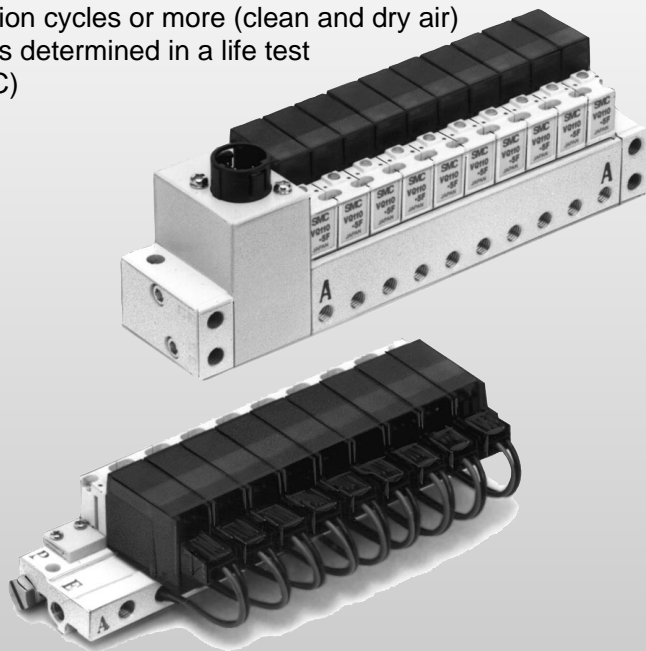

Compact with large flow capacity.

Body width: 9.8mm,
Cv: 0.02 (Standard, high pressure style)
Cv: 0.04 (Option, large flow style)

Options

External non-leak
Latching style
Negative COM specifications
AC voltage
Normally open
Vacuum (1)
Note 1) Consult SMC for vacuum specifications.

Copper-free specifications

The fluid contacting section is copper-free and the
standard style can be used as it is.

A wide variations of wiring

Manifold

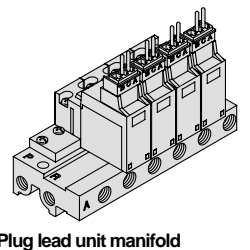
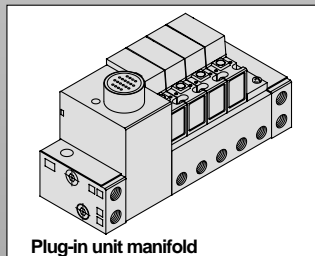

Single unit

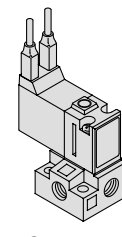
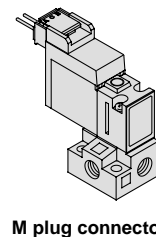
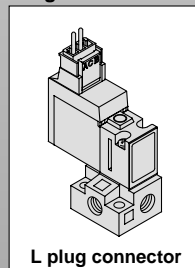

SY

SYJ

VK

VZ

VT

VT

VP

VG

VP

VQ

VQZ

VZ

VS

⚠️ Precautions

Be sure to read before handling. Refer to p.0-33 to 0-36 for Safety Instructions and common precautions.

⚠️ Warning

Manual Override

The connected equipment will be operated when manual override is used. Check carefully before handling to make sure that there is no danger.

■ Non-locking push flush style

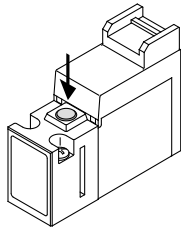

· It is turned ON by pushing the button in the direction indicated by the arrow until it hits the end and turned OFF by releasing the button.

■ Locking slotted style (Option)

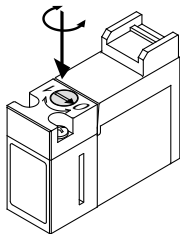

· It can be locked in the ON state by turning the manual override to the right, setting the ► mark to 1 and pushing it.
· It can be unlocked by turning the manual override to the left, setting the ► mark to 0 and pushing it, and the manual returns.

Note) Make sure the locking style manual override is unlocked before use.

■ Push locking slotted style (Latching style)

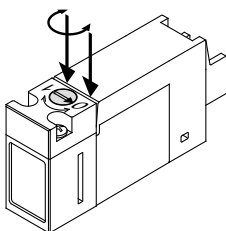

· It can be locked in the set state (flow: P → A) by turning the manual override to the right, setting the ► mark to 1 and pushing it.
· It can be turned back to the reset state (flow: A → R) by turning the manual override to the left, setting the ► mark to 0 and pushing it. (It is set in reset state when shipped.)

⚠️ Caution

When operating the lock style with a screwdriver, turn it softly using only small screwdrivers.

(Torque: Less than 0.1Nm)

⚠️ Caution

How to Use a Plug Connector

Connection/Disconnection of connector

- Push the connector straight onto the pins of the solenoid, making sure the lip of the lever is securely positioned in the groove on the solenoid cover.
- Press the lever against the connector and pull the connector away from the solenoid.

Note) GENTLY pull the lead wire, otherwise it may cause contact failure or disconnection.

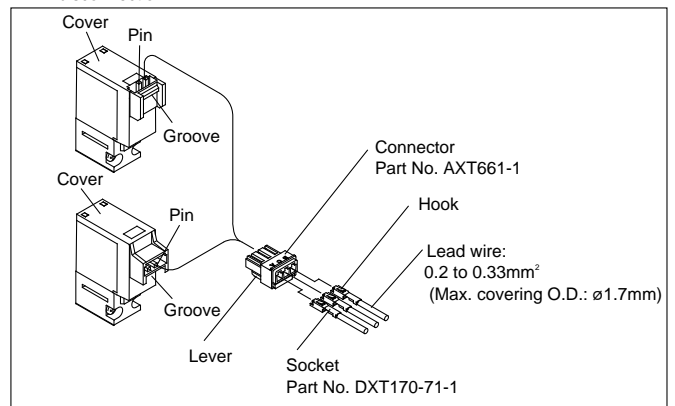

Crimping connection of lead wire and socket

Remove the insulation on the lead wire at the end from 3.2 to 3.7mm and insert the wires into the socket crimping area. Crimp the socket onto the wire using a crimping tool. Be careful not to let the insulation of the lead wire get into the wire crimping part. (Crimping tool: Part No. DXT170-75-1)

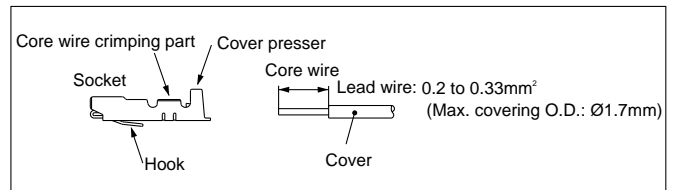

Connection/Disconnection of socket with lead wire

● Installation

Insert socket into the square hole (indicated as A, C and B) on the connector, hold the lead wire and push until it locks in place. Ensure that it is locked by pulling the lead wire a little.

● Removal

Pull and detach the lead wire, pressing in on the end of the hook of the socket through the side hole using a stick with thin end (about 1mm). To reuse the socket, extend the hook outward.

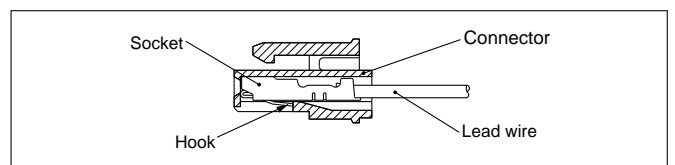

SY

SYJ

VK

VZ

VT

VT

VP

VG

VP

VQ

VQZ

VZ

VS

⚠️ Precautions

Be sure to read before handling. Refer to p.0-33 to 0-36 for Safety Instructions and common precautions.

⚠️ Caution

How to Use Plug Connector

Wiring

● Lead wires are connected as follows. Connect them to the power supply side.

DC Positive COM

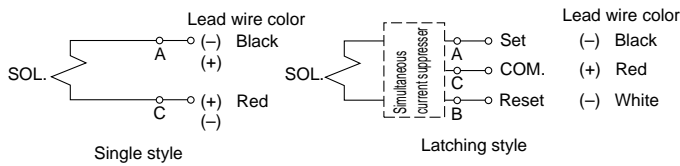

DC Negative COM

Note) Single style: No polarity

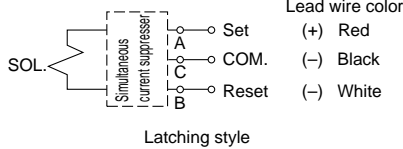

AC

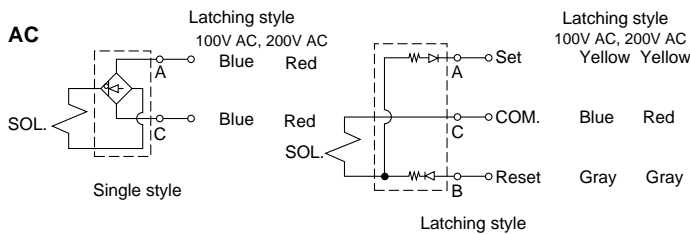

● How to Order Connector Assembly

DC Positive COM

•Single

AXT661-14A-

•Latching

AXT661-13A-

DC Negative COM

•Latching

AXT661-13AN-

100V AC

•Single

AXT661-31A-

•Latching

AXT661-32A-

200V AC

•Single

AXT661-34A-

•Latching

AXT661-35A-

●Lead wire length (mm)	
—	300
6	600
10	1000
20	2000
30	3000

● Plug connector lead wire length

The lead wire length of the valve with lead wire is 300mm. When ordering a valve with lead wire of 600mm or more, order the valve without lead wire and order the lead wire separately.

⚠️ Caution

Light and Surge Voltage Suppressor

For latching style, set energizing side and reset the energizing side are indicated with orange and green respectively.

* () and the broken line: Large flow capacity style

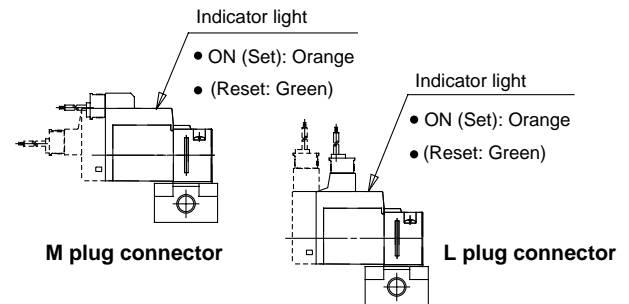

Single solenoid (DC)

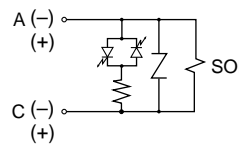

Latching solenoid (DC)

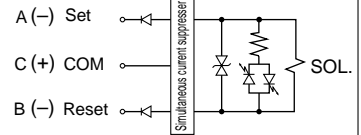

Single solenoid (AC)

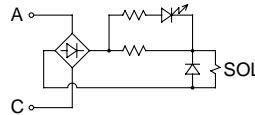

Latching solenoid (AC)

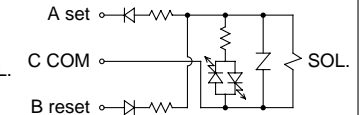

Note 1) Single: No polarity
ON: Orange light lights.
Note 2) Setting side energizing: Orange light lights.
Resetting side energizing: Green light lights.
With wrong wiring preventing ability (stop diode)
With surge voltage suppressor (ZNR/Surge absorbing diode)

Note 3) A (set) side energizing: P→A
B (set) side energizing: A→R
Note 4) Negative COM specification is applicable.

⚠️ Caution

Latching Style

The latching solenoid is equipped with a self-holding mechanism, which permits a movable iron core in the solenoid to hold the "set" position. Therefore there is no need to energize continuously.

<Special Cautions for Latching Solenoid>

1. Make sure ON and OFF signals are not energized simultaneously.
2. 10ms energizing time is necessary for self-holding.
3. Consult SMC if using in a place with high vibrations (10G or more) or high magnetic fields.
4. This valve is shipped in the "reset" position (passage: A → R). However, it may move to the "set" position during transportation or due to impacts during mounting. Therefore, check the initial position before use by means of a power supply or manual override.

Latching	Passage	Indicator light	Single	Passage	Indicator light
A-C ON (Set)	P→A	Orange	A-C ON	P→A	Orange
B-C ON (Reset)	A→R	Green	OFF	A→R	—

⚠ Caution

How to Use of Multi-connector (For plug-in manifold: For VV3Q11)

① Connector/Disconnection of Plug

- When mounting a connector: Align the positioning key grooves of the body to the key, and it is locked.
- When removing the connector: Pull the ring section straight back, and it is unlocked and then take it off.

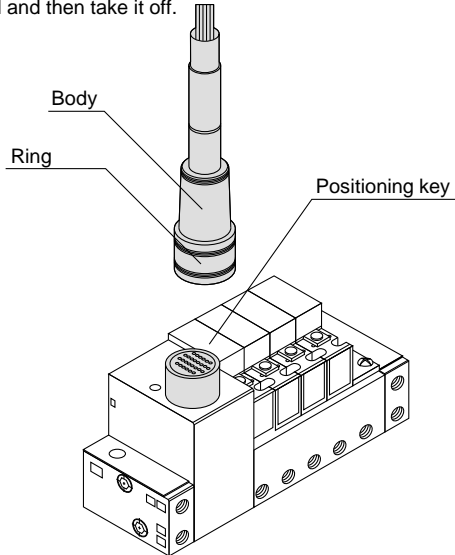

② Wiring Specifications

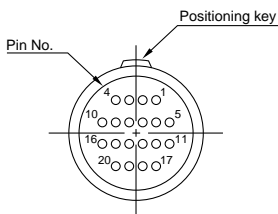

Multi-connector pin arrangement

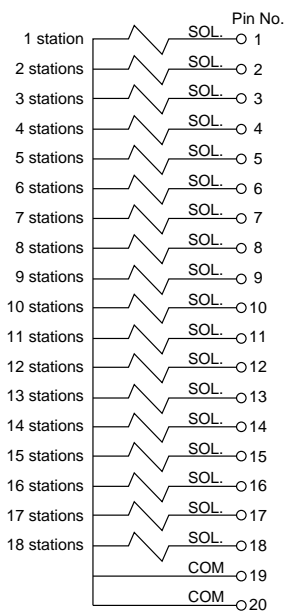

Electrical wiring specifications

Terminal No./Lead wire color

Terminal No.	Lead wire color	
	Wire color	Dot marking
1	Black	—
2	Brown	—
3	Red	—
4	Orange	—
5	Yellow	—
6	Pink	—
7	Blue	—
8	Violet	White
9	Gray	Black
10	White	Black
11	White	Red
12	Yellow	Red
13	Orange	Red
14	Yellow	Black
15	Pink	Black
16	Blue	White
17	Violet	—
18	Gray	—
19	Orange	Black
20	Red	White

⚠ Caution

How to Connect/Disconnect DIN Rail

Removing

- 1) Loosen the clamp screw of the end plate on both sides.
- 2) Lift side (A) of the manifold base and slide the end plate in the direction of (2) shown in the figure to remove.

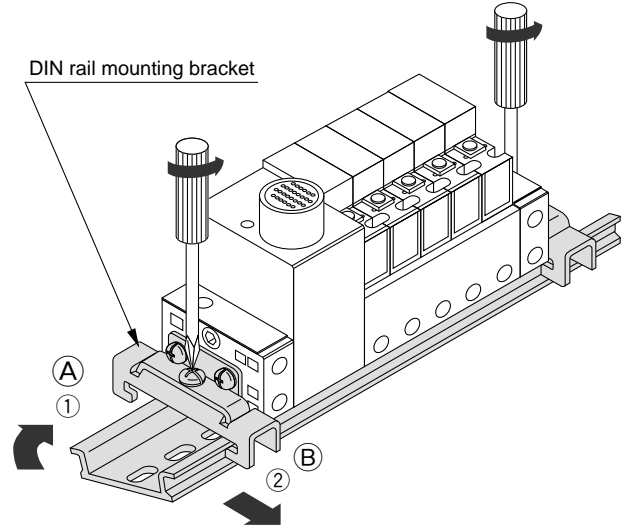

Mounting

- 1) Hook side (B) of the manifold base on the DIN rail.
- 2) Press down side (A) and mount the end plate on the DIN rail. Tighten the clamp screw on the side. Proper tightening torque of thread: 0.8 to 1.2Nm

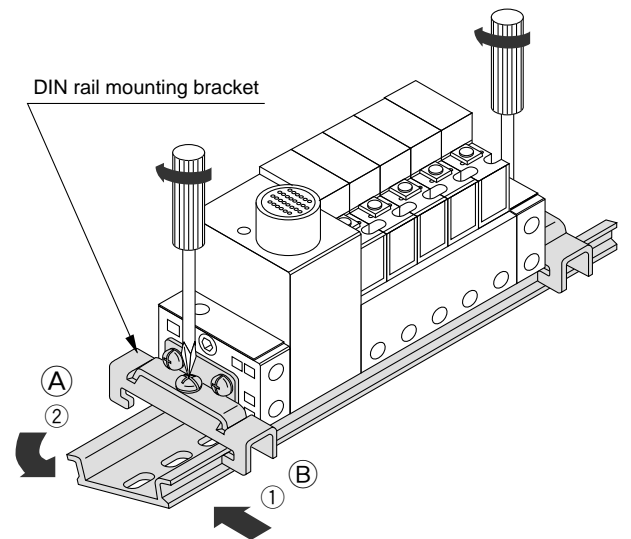

SY

SYJ

VK

VZ

VT

VT

VP

VG

VP

VQ

VQZ

VZ

VS

3 Port Solenoid Valve Series VQ100

How to Order Valve

VQ1 1 0 **5 F** **Port size**

Series VQ
Compact 3 port valve

Actuation

1	Normally closed
2	Normally open

Functions

—	Standard style (1W)
H	High pressure style (1.5W)
Y ⁽¹⁾	Low wattage style (0.5W)
L*	Latching style Positive COM
N*	Latching style Negative COM
U*	Large flow capacity style

* Option
Note 1) Except for latching and large flow capacity style.

Port size

—	Without sub-plate
M3	With sub-plate
M5	With sub-plate

Manual override

—	Non-locking push flush style
B*	Latching style: Push locking slotted style Locking slotted style

* Option
Note) Latching manual override: Push locking style only.

Electrical entry

F	Plug-in style With indicator light and surge voltage suppressor (only for plug-in manifold)	
L	L plug connector, With lead wire and light and surge voltage suppressor.	
LO	L plug connector, Without connector, With indicator light and surge voltage suppressor	
M	M plug connector, With lead wire and light and surge voltage suppressor.	
MO	M plug connector, Without connector, With indicator light and surge voltage suppressor	
G	Grommet	

* Option
Note) Grommet: No latching, AC and large flow capacity.

Coil Rated Voltage

1	100V AC (50/60Hz)
2	200V AC (50/60Hz)
3	110V AC (50/60Hz)
4	220V AC (50/60Hz)
5	24V DC
6	12V DC
9	Other

Consult SMC for other voltages.

L plug connector

M plug connector

Grommet

How to Order Valve

Series VQ
Compact 3 port valve

Actuation

1	Normally closed
2	Normally open

Functions

—	Standard (1W)
H	High pressure (1.5W)
Y ⁽¹⁾	Energy saver (0.5W)
L*	Latching Positive COM.
N*	Latching Negative COM
U*	Large flow capacity

* Option
Note 1) Except for latching and large flow capacity style.

Coil rated voltage

1	100V AC (50/60Hz)
2	200V AC (50/60Hz)
3	110V AC (50/60Hz)
4	220V AC (50/60Hz)
5	24V DC
6	12V DC
9	Other

Consult SMC for other voltages.

Port size

—	Without sub-plate
M3	With sub-plate
M5	With sub-plate

Manual override

—	Non-locking push flush style
B*	Latching style: Looking-push tool style
	Locking slotted style

* Option
Note) Latching style manual override: Looking-push slotted style only.

Electrical entry

L	L plug connector, With lead wire and light/surge voltage suppressor
LO	L plug connector, Without connector, With indicator light and surge voltage suppressor
M	M plug connector, With lead wire and light/surge voltage suppressor
MO	M plug connector Without connector, With indicator light and surge voltage suppressor.
G	Grommet

Note) Grommet: No latching style, AC and large flow capacity style

Dimensions

Grommet

VQ1□0□-□G□M5 (M3)

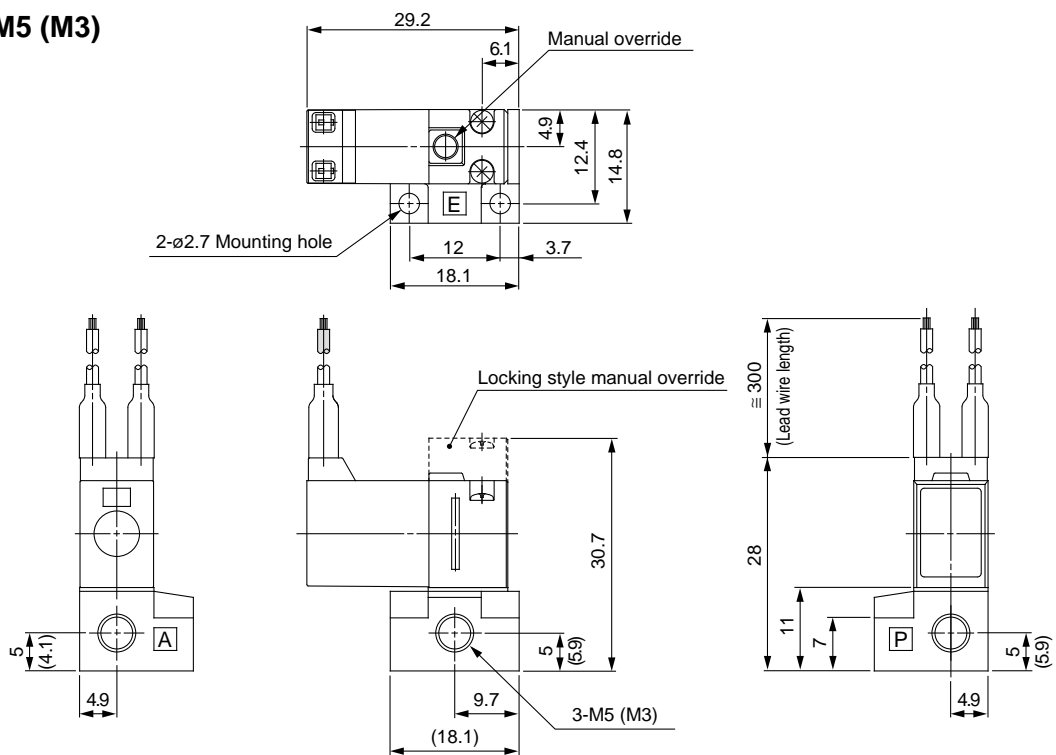

· () : M3
· Broken line: locking style manual override

Series VQ100

How to Order Manifold

Plug-in Unit Manifold

Applicable Solenoid Valve (Plug-in style)

VQ1□0□-□F

- Consult SMC for mounting latching style.
- Possible to mount U type (large flow capacity).



Note) Normally closed and normally open style cannot be mounted on the same manifold.

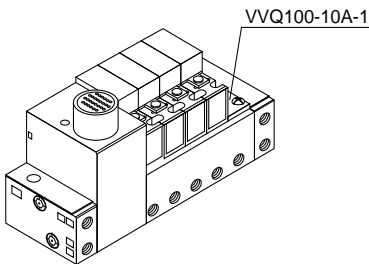

VV3Q 1 1 — 08 C U 1 — D

Series

1	VQ100
---	-------

Manifold base

1	Plug-in unit
---	--------------

Stations

02	2 stations
⋮	⋮
18	18 stations

Electrical entry

C	Multi-connector
---	-----------------

Connector location

U	Top entry
S	Side entry

Cable length

0	Without cable
1	With cable (1.5m)
2	With cable (3m)
3	With cable (5m)

Option

—	None
D	DIN rail mounted (With standard length of DIN rail)
DO ⁽¹⁾	DIN rail mounted (Without DIN rail)



Note 1) Order DIN rail separately. Refer to p.2.9-15 for "How to Order" for DIN rail.

How to Order Manifold Assembly

Suffix valve and option nos. to the manifold base No.

(Example)

Plug-in unit manifold with cable (3m)

VV3Q11-05CU2 1 set ——— Manifold base part No.
 * **VQ110-5F** 4 set ——— Valve part No. (1st to 4th stations)
 * **VVQ100-10A-1** 1 set ——— Blank plate (5th station)

Prefix with "*" to mark parts for ass'y nos. of solenoid valves, etc.

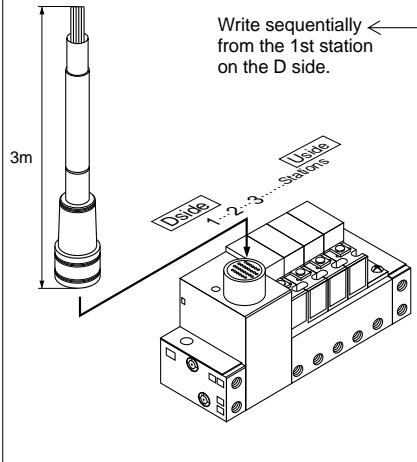

How to Order Valve

VQ1 1 0 □ — 5 F □

Series VQ Compact 3 port valve

Actuation

1	Normally closed
2	Normally open

Functions

—	Standard (1W)
H	High pressure (1.5W)
Y ⁽¹⁾	Low wattage (0.5W)
U*	Large flow capacity

*: Option
 Note 1) Except for large flow capacity style.

Manual override

—	Non-locking push flush style
B*	Locking slotted style

*: Option

Electrical entry

F	Plug-in style With indicator light and surge voltage suppressor (Only for plug-in manifold)
---	--

Coil rated voltage

1	100V AC (50/60Hz)
2	200V AC (50/60Hz)
3	110V AC (50/60Hz)
4	220V AC (50/60Hz)
5	24V DC
6	12V DC
9	Other



Consult SMC for peculiar voltages.

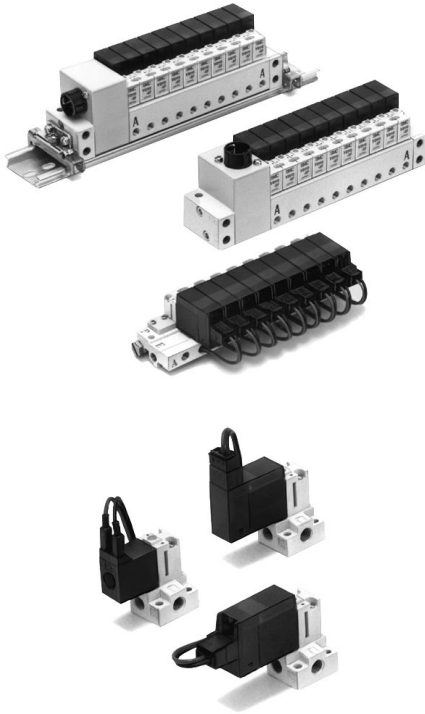

JIS symbol

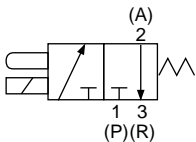

Normally closed

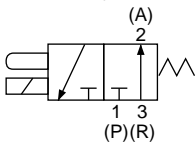

Normally open

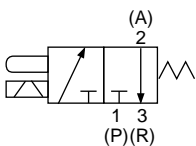

Latching style

Clean Series

Clean series is available for both standard and option specifications.

How to Order Valve

10-VQ110□-□

● Clean series

Standard Specifications

Item	Style	Standard (1W)	High pressure (1.5W)	Low wattage (0.5W)	
Valve	Valve structure	3 port direct operated poppet (NC)			
	Fluid	Air, Inert gas			
	Max. operating pressure	0.7MPa	0.8MPa	0.7MPa	
	Min. operating pressure	0MPa			
	Effective area	1→2	0.28mm ² (Cv 0.016)	0.14mm ² (Cv 0.008)	
		2→3	0.36mm ² (Cv 0.02)	0.20mm ² (Cv 0.011)	
	Response time ⁽¹⁾	ON: 3.5ms, OFF: 2ms		ON: 3.5ms, OFF: 2.5ms	
	Ambient and fluid temperature	-10 to 50°C ⁽²⁾			
	Lubrication	Not required			
	Manual override	Non-locking push/Locking slotted ⁽³⁾			
	Mounting operation	Free			
	Shock/Vibration resistance ⁽⁴⁾	150/30m/s ²			
	Protection structure	Dust proof			
Weight	12.6g (L/M connector, Without subplate)				
Solenoid	Coil rated voltage	DC	24V DC, 12V DC		
	Allowable voltage	±10% of rated voltage			
	Coil insulation	Class B or equivalent			
	Power consumption (Current)	DC	1W (42mA)	1.5W (63mA)	0.5W (21mA)
	Electrical entry	Grommet Plug-in, L plug connector, M plug connector (With indicator light and surge voltage suppressor)			



Note 1) As per JISB8374-1993. With light/surge voltage suppressor (clean air), Dispersion accuracy ±1ms

Note 2) Use dry air to prevent condensation when operating at low temperatures.

Note 3) Locking style: Option

Note 4) Shock resistance: No malfunction resulted from the impact test using a drop impact tester. The test was performed on the axis and right angle directions of the main valve and armature, for both energized and de-energized states.

Vibration resistance: No malfunction occurred in a one-sweep test between 8.3 and 2000Hz. Test was performed at both energized and de-energized states to the axis and right angle directions of the main valve and armature. (Value in the initial stage.)

Option Specifications

Item	Type	Latching	AC	Large flow capacity	Normally open	
Valve	Model	VQ110L-□	VQ110-½□	VQ110U-□	VQ120-□	
	Max. operating pressure	0.7MPa		0.6MPa	0.5MPa	
	Effective area	1→2	0.14mm ² (Cv _{0.008})	0.68mm ² (Cv _{0.038})		
		2→3	0.20mm ² (Cv _{0.011})	0.68mm ² (Cv _{0.038})	3→2 0.20mm ² (Cv _{0.011})	
Response time ⁽²⁾	5ms or less	6.5 or less	5ms or less	5ms or less		
Solenoid	Power consumption (Current)	24V DC	1W (42mA)	—	0.7W (29mA) ⁽³⁾	1W (42mA)
		12V DC	1W (83mA)	—	0.7W (29mA) ⁽³⁾	1W (83mA)
		100V AC	0.6VA (6mA)	0.5VA (5mA)	—	
		110V AC	0.65VA (5.9mA)	0.55VA (5mA)	—	
		200V AC	1.2VA (6mA)	1.0VA (5mA)	—	
		220V AC	1.3VA (5.9mA)	1.1VA (5mA)	—	
Electrical entry ⁽¹⁾	Plug-in, L plug connector, M plug connector (With indicator light and surge voltage suppressor)					



Note 1) Grommet is available only for normally open style (without light/surge voltage suppressor).

Note 2) With light/surge voltage suppressor based on JISB8374-1993 (clean air).

Note 3) Inrush: 3.1W (10ms after energized.), Holding: 0.7W

SY
SYJ
VK
VZ
VT
VT
VP
VG
VP
VQ
VQZ
VZ
VS

Dimensions

L plug connector

VQ1□0□-□L□M5 (M3)

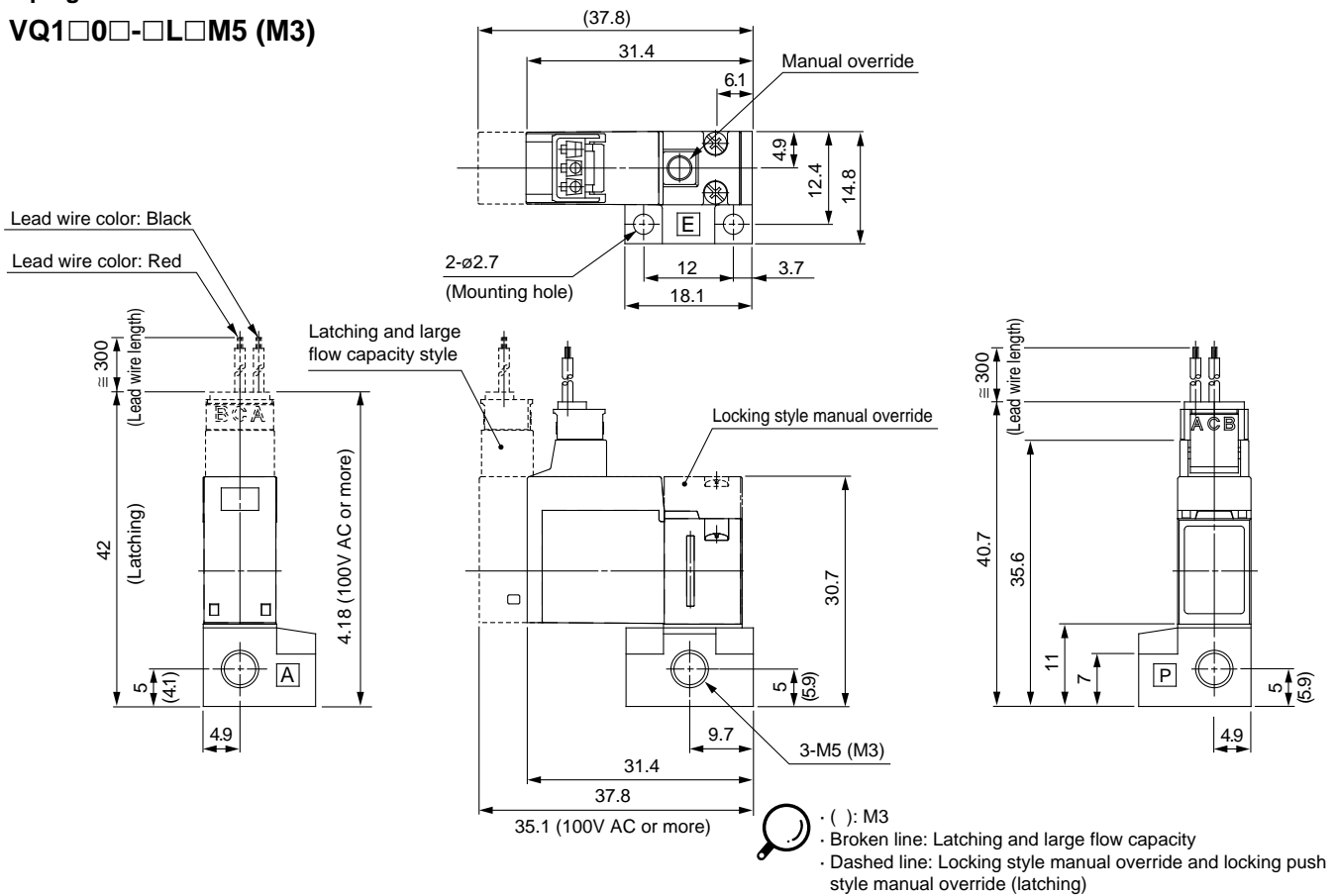

SY
SYJ
VK
VZ
VT
VT
VP
VG
VP
VQ
VQZ
VZ
VS

M plug connector

VQ1□0□-□M□M5 (M3)

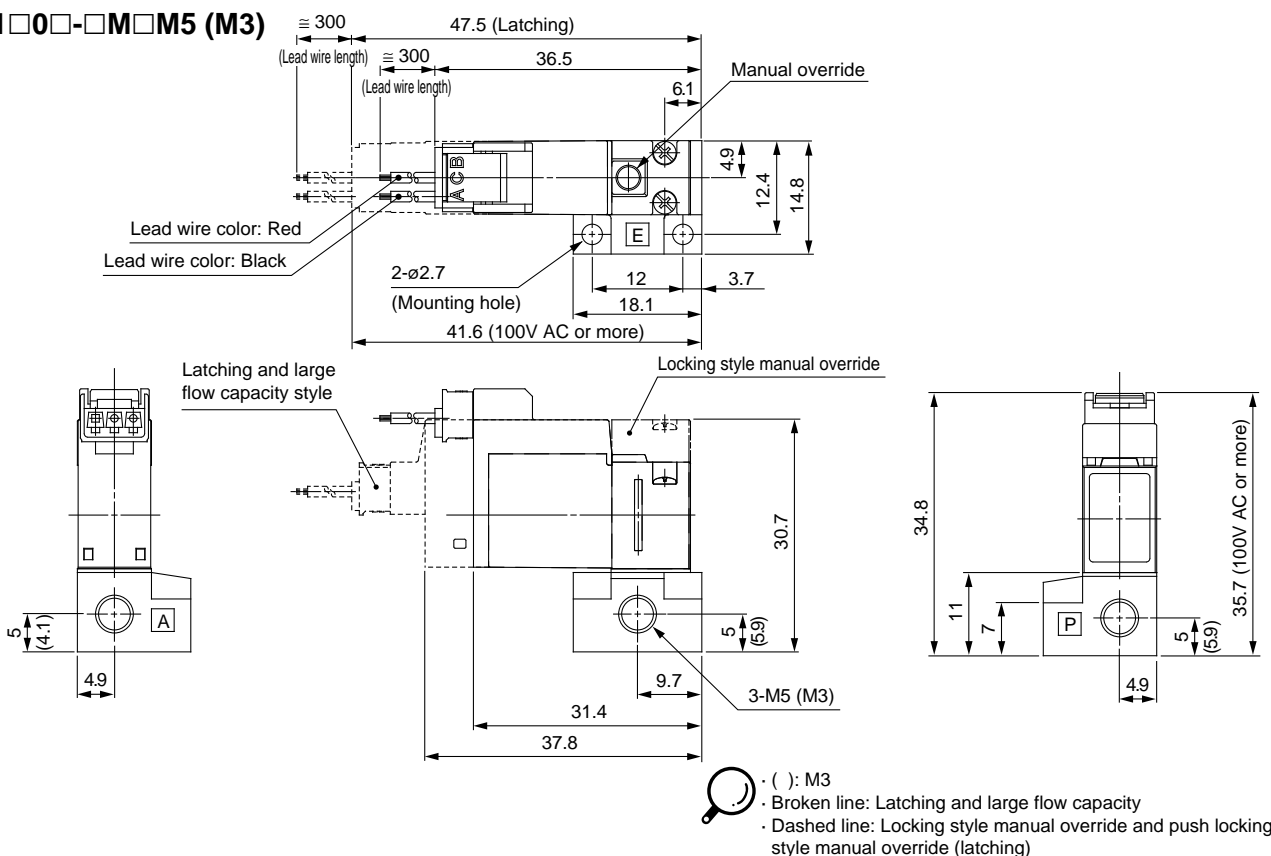

Plug-in Unit (VV3Q11) Manifold with Multi-connector

 The broken line indicates DIN rail mounted style (-D) and side entry connector (S).

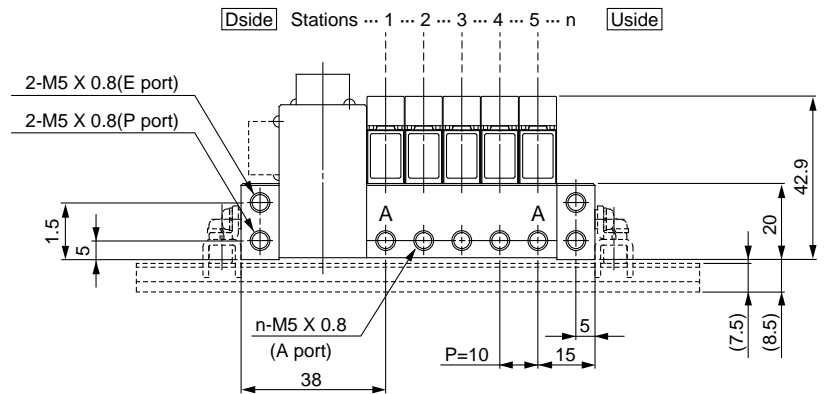
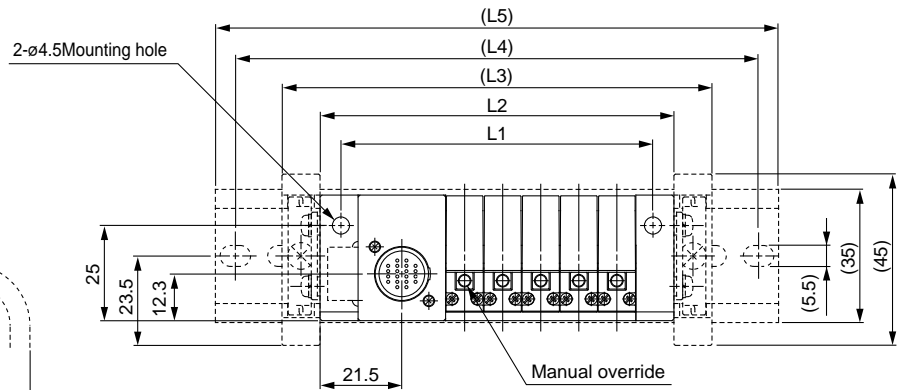
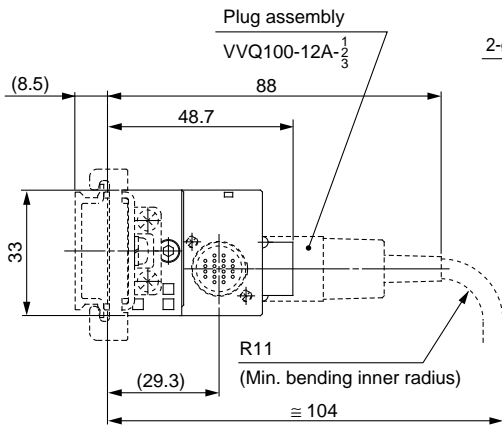

Dimensions

Equation: $L1=10n+32$ $L2=10n+43$ n: Station (Max. 18)

L \ n	2	3	4	5	6	7	8	9	10	11	12	13	14	15	16	17	18
L1	52	62	72	82	92	102	112	122	132	142	152	162	172	182	192	202	212
L2	63	73	83	93	103	113	123	133	143	153	163	173	183	193	203	213	223
(L3)	83	93	103	113	123	133	143	153	163	173	183	193	203	213	223	233	243
(L4)	112.5	112.5	125	137.5	150	162.5	162.5	175	187.5	200	212.5	212.5	225	237.5	250	262.5	262.5
(L5)	123	123	135.5	148	160.5	173	173	185.5	198	210.5	223	223	235.5	248	260.5	273	273

SY

SYJ

VK

VZ

VT

VT

VP

VG

VP

VQ

VQZ

VZ

VS

Series VQ100

How to Order Manifold

Plug Lead Unit Manifold

Applicable Solenoid Valve (Plug lead style)
 VQ1□0□-□L
 VQ1□0□-□M
 VQ1□0□-□G

Note) Normally closed and normally open style cannot be mounted on the same manifold.

VV3Q1 2 08 01N

Series

1	VQ100
---	-------

Manifold base

2	Plug lead unit
2U	Plug lead unit U type (large flow capacity) mounting base

Stations

02	2 stations
⋮	⋮
20	20 stations

Port size* and thread

—	M5, Rc(PT)1/8
01N	NPT1/8
01T	NPTF1/8
01F	G(PF)1/8

* Only thread port size 1/8 style (2U type, P/E port) has choice of thread.

How to Order Manifold Assembly

Suffix valve and option numbers for the manifold base No.

(Example)
 Plug lead unit manifold with cable (3m)
VV3Q12-05 1 set Manifold base No.
 * **VQ110-5L** 4 sets Valve No. (1st to 4th stations)
 * **VVQ100-10A-2** 1 set Blank plate part No. (5th station)

Place "*" in front of the part No. of solenoid valve which is to be mounted.

Write sequentially from the 1st station on the D side.

How to Order Valve

Series VQ Compact 3port valve

VQ1 1 0 □ - 5 L □

Actuation

1	Normally close
2	Normally open

Functions

—	Standard (1W)
H	High pressure (1.5W)
Y ⁽¹⁾	Low wattage (0.5W)
L*	Latching
N*	Negative COM
U*	Large flow capacity

*: Option
 Note) Except for latching and large flow capacity style.

Coil rated voltage

1	100V AC (50/60Hz)
2	200V AC (50/60Hz)
3	110V AC (50/60Hz)
4	220V AC (50/60Hz)
5	24V DC
6	12V DC
9	Other

Consult SMC for other voltages.

Manual override

—	Non-locking push flush style
	Latching type: Looking-push slotted style
B*	Locking slotted style

*: Option
 Note) Latching manual override: Looking-push style only.

Electrical entry

L	L plug connector, With lead wire and light/surge voltage suppresser
LO	L plug connector, Without connector, With indicator light and surge voltage suppresser
M	M plug connector, With lead wire and light/surge voltage suppresser
MO	M plug connector, Without connector, With light/surge voltage suppresser
G	Grommet

Note) Grommet: No AC and large flow capacity style.

Series VQ100

Construction

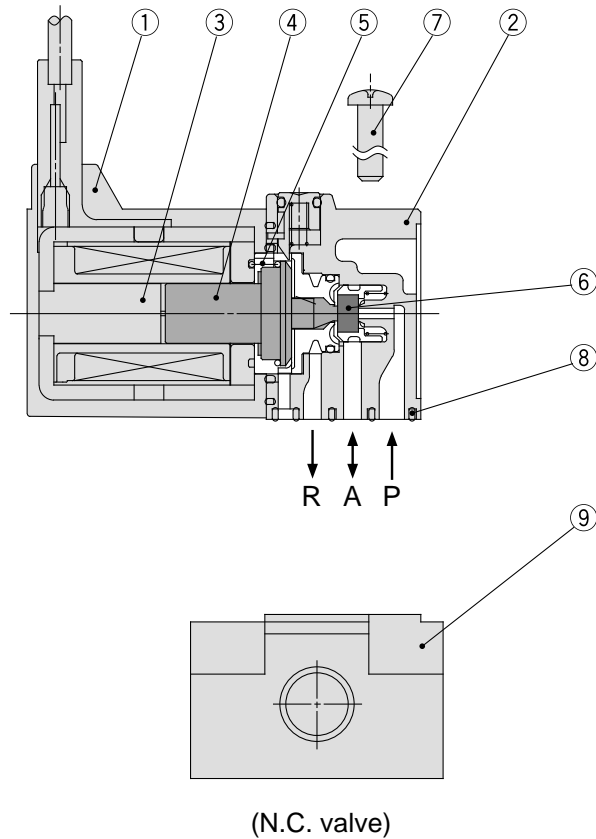

(N.C. valve)

Component Parts

No.	Description	Material
①	Solenoid coil	—
②	Body	Resin
③	Fixed iron core	Stainless steel
④	Movable iron core assembly	Stainless steel, Resin
⑤	Return spring	Stainless steel
⑥	Poppet	NBR
⑦	Phillips/ordinary round head screw	Carbon steel
⑧	Interface gasket	NBR

Replacement Parts

No.	Part	Material	Part No.
⑨	Sub-plate	ZDC	AXT662-1- $\frac{1}{2}$ (1: M5, 2: M3)

Optional Parts

· Gasket, screw: VQ100-GS-5



Note) 1 set includes: 1 gasket and 2 screws. Please order 10 sets at a time.

Manifold Option

Plug Assembly

VVQ100-12A-¹/₂/₃

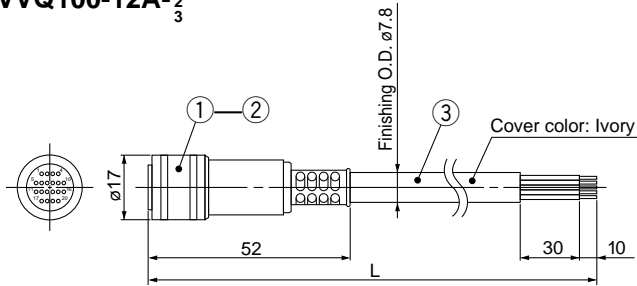

1	Plug	RP13A-12PS-20SC (Made by Hirose Electric)
2	Female contact	RP19-SC-222 (Made by Hirose Electric)
3	Vinyl multi-core cable	VVRF 0.2mm ² 20-core

Cable Length

Model	L dimensions
VVQ100-12A-1	1.5m
VVQ100-12A-2	3m
VVQ100-12A-3	5m

Blank Plate Assembly

VVQ100-10A-1

Plug-in unit (VV3Q11) for manifold with multiple connectors

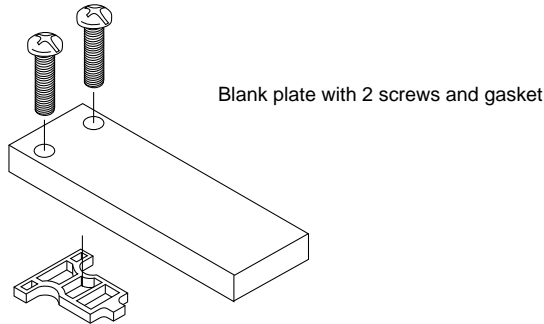

VVQ100-10A-2

Plug lead unit (VV3Q12) for manifold

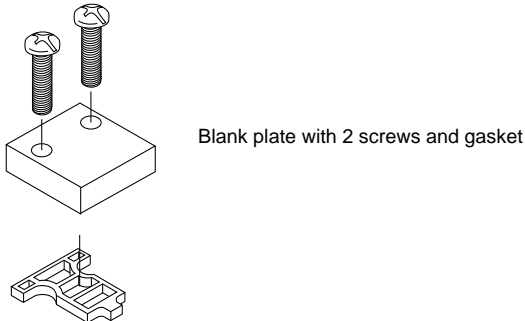

VV3Q11 For Manifold With Multi-connector

< D Side End Plate Assembly >

D side end plate assembly part number

VVQ100-3A-□

Option

1	Standard
2	DIN rail mounting

< U Side End Plate Assembly >

U side end plate assembly part number

VVQ100-2A-□

Option

1	Standard type
2	DIN rail mounting

< DIN Rail Mounting Bracket Assembly >

DIN rail mounting bracket part number.

AXT802-1A-□

Mounting direction

D	D side mounting
U	U side mounting



Note) The number of manifold stations cannot be changed.

How to Order Only DIN Rail

DIN rail part number: AXT100-DR-□

*Refer to DIN rail dimension table below and put number into □ to order DIN rail. Refer to the manifold dimensions on p.2.9-11 to know L size.

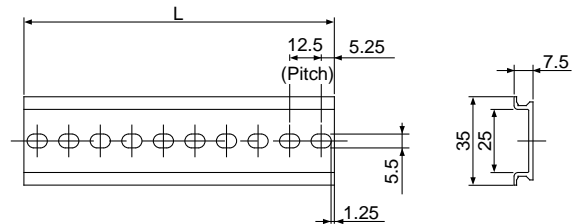

L Size Dimensions

L=12.5n+10.5

No.	1	2	3	4	5	6	7	8	9	10
L size	23	35.5	48	60.5	73	85.5	98	110.5	123	135.5
No.	11	12	13	14	15	16	17	18	19	20
L size	148	160.5	173	185.5	198	210.5	223	235.5	248	260.5
No.	21	22	23	24	25	26	27	28	29	30
L size	273	285.5	298	310.5	323	335.5	348	360.5	373	385.5
No.	31	32	33	34	35	36	37	38	39	40
L size	398	410.5	423	435.5	448	460.5	473	485.5	498	510.5