

Compact Cylinder: Standard Double Acting, Double Rod CQ2W Series

ø12, ø16, ø20, ø25, ø32, ø40, ø50, ø63, ø80, ø100

How to Order

Without auto switch
ø12 to ø25

Without auto switch
ø32 to ø100

With auto switch

CQ2W B □ 20 □ - 30 D □ - □

CQ2W B □ 32 □ - 30 D □ Z - □

CDQ2W B □ 32 □ - 30 D M Z - M9BW □ - □

Mounting	
B	Through-hole (Standard)
A	Both ends tapped
L	Foot
LC	Compact foot
F	Flange

- * Mounting brackets are shipped together (but not assembled).
- * Cylinder mounting bolts are not included. Order them separately referring to "Mounting Bolt for CQ2" on pages 802 and 805.

Type

Nil	Pneumatic
H	Air-hydro (Note 1)

Note 1) Bore sizes available for air-hydro type are ø20 to ø100.

Bore size

12	12 mm	40	40 mm
16	16 mm	50	50 mm
20	20 mm	63	63 mm
25	25 mm	80	80 mm
32	32 mm	100	100 mm

Auto switch mounting groove	
Z	ø12 to ø25 2 surfaces
	ø32 to ø100 4 surfaces

Number of auto switches

Nil	2 pcs.
S	1 pc.
n	"n" pcs.

Body option

Nil	Standard (Rod end female thread)
C	With rubber bumper (Note 4)
M	Rod end male thread

- * Combination of body options ("CM") is available.
- Note 4) Air-hydro type with rubber bumper is not available.

Auto switch

Nil	Without auto switch
------------	---------------------

* Refer to the below table for applicable auto switches.

Made to Order

Refer to page 800 for details.

Action

D	Double acting
----------	---------------

Port thread type

Nil	M thread	ø12 to ø25
	Rc	
TN	NPT	ø32 to ø100
TF	G	
F	Built-in One-touch fittings (Note 2)	

Cylinder stroke (mm)

Refer to page 800 for standard strokes.

Built-in Magnet Cylinder Model

If a built-in magnet cylinder without an auto switch is required, there is no need to enter the symbol for the auto switch.

(Example) CDQ2WL32-25DZ

Note 2) Bore sizes available with One-touch fittings are ø32 to ø63. Besides, it is not possible to use for air-hydro type.

Note 3) "TF" is not available for the air-hydro type.

* For cylinders without auto switch, M threads are compatible only for ø32-5 mm stroke.

Applicable Auto Switches/Refer to pages 1575 to 1701 for further information on auto switches.

Type	Special function	Electrical entry	In-cylinder light	Wiring (Output)	Load voltage		Auto switch model		Lead wire length (m)					Pre-wired connector	Applicable load
					DC	AC	Perpendicular	In-line	0.5 (Nil)	1 (M)	3 (L)	5 (Z)	None (N)		
Solid state auto switch	—	Grommet	Yes	3-wire (NPN)	24 V	—	M9NV	M9N	●	●	○	○	○	○	IC circuit
				3-wire (PNP)			M9PV	M9P	●	●	○	○	○		
				2-wire			M9BV	M9B	●	●	○	○	○		
				2-wire (Non-polar)			—	P3DWA	●	—	●	○	○		
	Diagnostic indication (2-color indicator)	Grommet	Yes	3-wire (NPN)	24 V	—	M9NVW	M9NW	●	●	○	○	○	○	IC circuit
				3-wire (PNP)			M9PVW	M9PW	●	●	○	○	○		
				2-wire			M9BWW	M9BW	●	●	○	○	○		
				2-wire (Non-polar)			—	P3DWA	●	—	●	○	○		
Water resistant (2-color indicator)	Grommet	Yes	3-wire (NPN)	24 V	—	M9NAV*1	M9NA*1	○	○	○	○	○	○	IC circuit	
			3-wire (PNP)			M9PAV*1	M9PA*1	○	○	○	○	○			
			2-wire			M9BAV*1	M9BA*1	○	○	○	○	○			
			2-wire (Non-polar)			—	P3DWA	●	—	●	○	○			
Reed auto switch	—	Grommet	Yes	3-wire (NPN equivalent)	24 V	—	A96V	A96	●	—	—	—	—	IC circuit	
				100 V			A93V*2	A93	●	●	●	—	—		
				5 V, 12 V, 100 V or less			A90V	A90	●	—	●	—	—		
			No	2-wire	24 V	—	—	—	—	—	—	—	—	IC circuit	

*1 Water resistant type auto switches can be mounted on the above models, but in such case SMC cannot guarantee water resistance.

Consult with SMC regarding water resistant types with the above model numbers.

- *2 1 m type lead wire is only applicable to D-A93.
- * Lead wire length symbols: 0.5 m Nil (Example) M9NV
- 1 m M (Example) M9NVW
- 3 m L (Example) M9NVW
- 5 m Z (Example) M9NVWZ

- * Solid state auto switches marked with "○" are produced upon receipt of order.
- * The D-P3DWA□ type is available from ø25 to ø100 only.

* There are other applicable auto switches other than the listed above. For details, refer to page 970.

* For details about auto switches with pre-wired connector, refer to pages 1648 and 1649.

CQ2W Series



Symbol

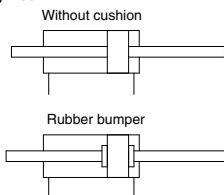

Made to Order: Individual Specifications
(For details, refer to pages 971 to 980.)

Symbol	Specifications
-X144	Special port location, with auto switch $\phi 12$ to $\phi 25$ only
-X235	Special rod end for double rod cylinder
-X271	Fluororubber seals
-X293	Full length dimension is the same as CQ1W series.
-X633	Intermediate stroke of double rod cylinder

Made to Order

[Click here for details](#)

Symbol	Specifications
-XA□	Change of rod end shape
-XB6	Heat resistant cylinder (-10 to 150°C) w/o auto switch only
-XB7	Heat resistant cylinder (-40 to 70°C) w/o auto switch only
-XB9	Low-speed cylinder (10 to 50 mm/s)
-XB10	Intermediate stroke (Exclusive body type)
-XB13	Low-speed cylinder (5 to 50 mm/s)
-XC2(A)	Rod end length, 10 mm increased (For foot and flange bracket)
-XC4	With heavy-duty scraper, $\phi 40$ to $\phi 100$ only
-XC6	Piston rod/Retaining ring/Rod end nut material: Stainless steel
-XC35	With coil scraper, $\phi 32$ to $\phi 100$ only
-XC36	With boss on rod end
-XC85	Grease for food processing equipment

Moisture Control Tube IDK Series



When operating an actuator with a small diameter and a short stroke at a high frequency, the dew condensation (water droplet) may occur inside the piping depending on the conditions.

Simply connecting the moisture control tube to the actuator will prevent dew condensation from occurring. For details, refer to [the IDK series in the Best Pneumatics No. 6](#).

Specifications

Pneumatic type

Bore size (mm)	12	16	20	25	32	40	50	63	80	100	
Action	Double acting, Double rod										
Fluid	Air										
Proof pressure	1.5 MPa										
Maximum operating pressure	1.0 MPa										
Minimum operating pressure	0.07 MPa					0.05 MPa					
Ambient and fluid temperature	Without auto switch: -10 to 70°C (No freezing) With auto switch: -10 to 60°C (No freezing)										
Lubrication	Not required (Non-Lube)										
Piston speed	50 to 500 mm/s										
Allowable kinetic energy (J)	Standard	0.022	0.038	0.055	0.09	0.15	0.26	0.46	0.77	1.36	2.27
	With rubber bumper	0.043	0.075	0.11	0.18	0.29	0.52	0.91	1.54	2.71	4.54
Stroke length tolerance	+1.0 mm (Note) 0										

Note) Stroke length tolerance does not include the amount of bumper change.

Air-hydro type

Bore size (mm)	20	25	32	40	50	63	80	100
Action	Double acting, Double rod							
Fluid	Turbine oil (Note)							
Proof pressure	1.5 MPa							
Maximum operating pressure	1.0 MPa							
Minimum operating pressure	0.18 MPa				0.1 MPa			
Ambient and fluid temperature	5 to 60°C							
Piston speed	5 to 50 mm/s							
Cushion	None							
Stroke length tolerance	+1.0 mm 0							

Note) Refer to page 7 for Actuator Precautions (5).

Standard Strokes

Pneumatic type (Non-lube)	(mm)
Bore size	Standard stroke
12, 16	5, 10, 15, 20, 25, 30
20, 25	5, 10, 15, 20, 25, 30 35, 40, 45, 50
32, 40	5, 10, 15, 20, 25, 30 35, 40, 45, 50, 75, 100
50, 63	10, 15, 20, 25, 30
80, 100	35, 40, 45, 50, 75, 100

Air-hydro type	(mm)
Bore size	Standard stroke
20, 25	5, 10, 15, 20, 25, 30 35, 40, 45, 50
32, 40	5, 10, 15, 20, 25, 30 35, 40, 45, 50, 75, 100
50, 63	10, 15, 20, 25, 30
80, 100	35, 40, 45, 50, 75, 100

Manufacture of Intermediate Strokes

Type	A spacer is installed in the standard stroke body. (5 mm intervals)	A spacer is installed in the standard stroke body. (1 mm intervals)	Exclusive body (-XB10)			
Part no.	Refer to "How to Order" for the standard model number. (P. 799)	Suffix "-X633" (P. 799) to the end of standard model number. (P. 978)	Suffix "-XB10" to the end of standard model number. (P. 799)			
Description	Strokes in 5 mm increments are available by installing a spacer in the standard stroke cylinder.	Strokes in 1 mm increments are available by installing a spacer in the standard stroke cylinder.	Strokes in 1 mm increments are available by using an exclusive body with the specified stroke.			
Stroke range	Bore size	Stroke range	Bore size	Stroke range		
	—	—	12, 16	6 to 29	12, 16	6 to 29
Example	32 to 100	55 to 95	20, 25	6 to 49	20, 25	6 to 49
	Part no.: CQ2WB50-65DZ CQ2WB50-75DZ with 10 mm width spacer inside The B dimension is 125.5 mm.	Part no.: CQ2WB50-72DZ-X633 CQ2WB50-75DZ with 3 mm width spacer inside The B dimension is 125.5 mm.	32, 40	6 to 99	32, 40	6 to 99
		50 to 100	11 to 99	50 to 100	11 to 99	
			Part no.: CQ2WB50-65DZ-XB10 Makes 65 mm stroke tube. The B dimension is 115.5 mm.			

- Except air-hydro type
- In the case of spacer type, intermediate strokes with bumper for $\phi 40$ to $\phi 100$, "-X633" is not available.
- In the case of exclusive body type with $\phi 32$ to $\phi 100$ (-XB10) with the stroke length exceeding 50 mm, reference values of the longitudinal dimension will be changed.
Calculate length dimensions by deducting from those of 75 or 100 mm stroke models.

Refer to pages 964 to 970 for the specifications of cylinders with autoswitches.

- Auto switch proper mounting position (detection at stroke end) and its mounting height
- Minimum stroke for auto switch mounting
- Operating range
- Auto switch mounting brackets/Part no.

Type

Bore size (mm)		12	16	20	25	32	40	50	63	80	100	
Pneumatic	Mounting	●	●	●	●	●	●	●	●	●	●	
	Through-hole (Standard)	●	●	●	●	●	●	●	●	●	●	
	Both ends tapped	●	●	●	●	●	●	●	●	●	●	
Pneumatic	Built-in magnet	●	●	●	●	●	●	●	●	●	●	
	Piping	—	M5 x 0.8	M5 x 0.8	M5 x 0.8	M5 x 0.8	Note 1) M5 x 0.8 Rc1/8	Rc1/8	Rc1/4	Rc1/4	Rc3/8	Rc3/8
		TN	—	—	—	—	NPT1/8	NPT1/8	NPT1/4	NPT1/4	NPT3/8	NPT3/8
	TF	—	—	—	—	G1/8	G1/8	G1/4	G1/4	G3/8	G3/8	
	Built-in One-touch fittings	Note 3)	—	—	—	ø6	Note 2)	ø6	ø8	ø8	—	—
	Rod end male thread	●	●	●	●	●	●	●	●	●	●	●
	With rubber bumper	●	●	●	●	●	●	●	●	●	●	●
	Air-hydraulic	Mounting	—	—	●	●	●	●	●	●	●	●
		Through-hole (Standard)	—	—	●	●	●	●	●	●	●	●
		Both ends tapped	—	—	●	●	●	●	●	●	●	●
Air-hydraulic	Built-in magnet	—	—	●	●	●	●	●	●	●	●	
	Piping	—	—	M5 x 0.8	M5 x 0.8	Note 1) M5 x 0.8 Rc1/8	Rc1/8	Rc1/4	Rc1/4	Rc3/8	Rc3/8	
		TN	—	—	—	—	NPT1/8	NPT1/8	NPT1/4	NPT1/4	NPT3/8	NPT3/8
Rod end male thread	—	—	●	●	●	●	●	●	●	●	●	

Note 1) ø32 without auto switch; M5 x 0.8 is used for 5 mm stroking dimension.

Thus, do not enter a symbol for the port thread type.

Note 2) The dimension of the ø32-5 mm stroke with built-in One-touch fittings is the same as that of the 10 mm stroke cylinder tube.

Note 3) One-touch fittings cannot be replaced.

Retaining Ring Installation/Removal

⚠ Caution

- For installation and removal, use an appropriate pair of pliers (tool for installing a type C retaining ring).
- Even if a proper plier (tool for installing a type C retaining ring) is used, it is likely to inflict damage to a human body or peripheral equipment, as a retaining ring may be flown out of the tip of a plier (tool for installing a type C retaining ring). Be much careful with the popping of a retaining ring. Besides, be certain that a retaining ring is placed firmly into the groove of rod cover before supplying air at the time of installment.

Mounting

⚠ Warning

Do not apply reverse torque to the piston rods sticking out from both sides of this cylinder at the same time. The torque makes connection threads inside loosen, which may cause an accident or malfunction.

Install or remove loads while the piston rod width across flat is secured. Do not fix the other side of the piston rod width across flat and apply reverse torque.

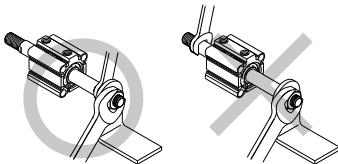

Mounting Brackets/Part No.

Bore size (mm)	Model	Foot (Note 4)	Compact foot (Note 4)	Flange
12	Without switch	CQ2□□-□□	CQ-L012	CQ-LC012
	With switch	CQ2□□-□□Z	CQ-LZ012	CQ-LCZ12
16	Without switch	CQ2□□-□□	CQ-L016	CQ-LC016
	With switch	CQ2□□-□□Z	CQ-LZ016	CQ-LCZ16
20	Without switch	CQ2□□-□□	CQ-L020	CQ-LC020
	With switch	CQ2□□-□□Z	CQ-LZ020	CQ-LCZ20
25	Without switch	CQ2□□-□□	CQ-L025	CQ-LC025
	With switch	CQ2□□-□□Z	CQ-LZ025	CQ-LCZ25
32	CQ2□□-□□Z	CQ-L032	CQ-LC032	CQ-F032
40	CQ2□□-□□Z	CQ-L040	CQ-LC040	CQ-F040
50	CQ2□□-□□Z	CQ-L050	CQ-LC050	CQ-F050
63	CQ2□□-□□Z	CQ-L063	CQ-LC063	CQ-F063
80	CQ2□□-□□Z	CQ-L080	CQ-LC080	CQ-F080
100	CQ2□□-□□Z	CQ-L100	CQ-LC100	CQ-F100

Note 4) When ordering foot and compact foot brackets, the required quantity will be different depending on the bore size.

ø12 to ø25:

• Without switch: Order 2 pieces per cylinder.

• With switch: Order 1 piece per cylinder. (Part number for a set of 2 foot brackets)

ø32 to ø100:

• Order 2 pieces per cylinder.

Note 5) Parts belonging to each bracket are as follows.

Foot, Compact foot, Flange: Body mounting bolts

Note 6) For details about accessories (options), refer to page 796.

Allowable Lateral Load at Rod End

Without Auto Switch

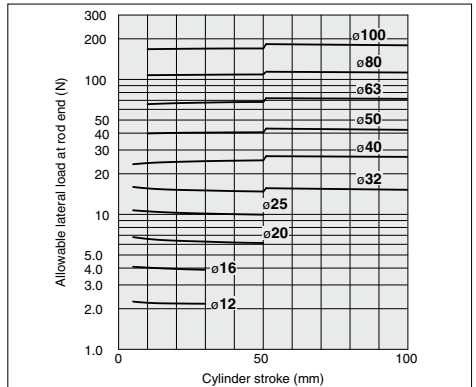

With Auto Switch

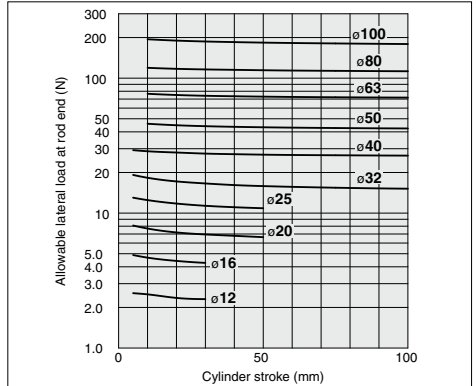

CUJ

CU

CQS

JCQ

CQ2

RQ

CQM

CQU

MU

D-□

-X□

Technical Data

CQ2W Series

Theoretical Output

Bore size (mm)	Operating pressure (MPa)		
	0.3	0.5	0.7
12	25	42	59
16	45	75	106
20	71	118	165
25	113	189	264
32	181	302	422
40	317	528	739
50	495	825	1150
63	841	1400	1960
80	1360	2270	3170
100	2140	3570	5000

Weight

Bore size (mm)	Cylinder stroke (mm)											
	5	10	15	20	25	30	35	40	45	50	75	100
12	42	49	56	63	70	77	—	—	—	—	—	—
16	59	68	77	86	95	104	—	—	—	—	—	—
20	89	104	119	134	149	164	179	194	209	224	—	—
25	119	136	153	170	187	204	221	238	255	272	—	—
32	185	212	235	257	280	303	326	349	372	395	555	670
40	279	308	337	367	396	426	455	484	514	543	749	896
50	—	497	538	580	622	664	705	747	789	830	1122	1331
63	—	646	682	718	754	790	826	862	899	935	1187	1368
80	—	1149	1225	1302	1378	1455	1531	1608	1684	1760	2296	2678
100	—	1960	2068	2177	2286	2394	2503	2612	2720	2829	3589	4132

Additional Weight

Bore size (mm)	12	16	20	25	32	40	50	63	80	100	
Both ends tapped	2	2	6	6	6	6	6	19	45	45	
Rod end male thread	Male thread	3	6	12	24	52	54	106	106	240	350
	Nut	2	4	8	16	34	34	64	64	98	232
With rubber bumper	0	0	-2	-2	-3	-7	-12	-20	-34	-57	
Built-in One-touch fittings	—	—	—	—	12	12	21	21	—	—	
Foot (Including mounting bolts)	57	71	170	195	158	170	267	342	722	1107	
Compact foot (Including mounting bolts)	41	51	121	140	99	114	177	241	501	770	
Flange (Including mounting bolts)	57	69	139	161	180	214	373	559	1056	1365	

Calculation: (Example) CQ2WF32-20DCMZ

- Basic weight: CQ2WB32-20DZ 257 g
- Additional weight: Both ends tapped 6 g
- Rod end male thread 86 g
- With rubber bumper -3 g
- Flange 180 g

526 g

Mounting Bolt for CQ2WB/Without Auto Switch

Mounting method: Mounting bolt for through-hole mounting of the CQ2WB is available as an option. Refer to the following for ordering procedures. Order the actual number of bolts that will be used.

Example) CQ-M3 x 35L 4 pcs.

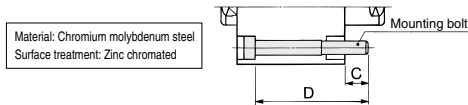

Material: Chromium molybdenum steel
Surface treatment: Zinc chromated

Cylinder model	C	D	Mounting bolt part no.
CQ2WB12-5D	8.3	35	CQ-M3 x 35L
-10D		40	x 40L
-15D		45	x 45L
-20D		50	x 50L
-25D		55	x 55L
-30D		60	x 60L
CQ2WB16-5D	7.5	35	CQ-M3 x 35L
-10D		40	x 40L
-15D		45	x 45L
-20D		50	x 50L
-25D		55	x 55L
-30D		60	x 60L
CQ2WB20-5D	6	30	CQ-M5 x 30L
-10D		35	x 35L
-15D		40	x 40L
-20D		45	x 45L
-25D		50	x 50L
-30D		55	x 55L
-35D	60	x 60L	
-40D	65	x 65L	
-45D	70	x 70L	
-50D	75	x 75L	
CQ2WB25-5D	8	35	CQ-M5 x 35L
-10D		40	x 40L
-15D		45	x 45L
-20D		50	x 50L
-25D		55	x 55L
-30D		60	x 60L
-35D	65	x 65L	
-40D	70	x 70L	
-45D	75	x 75L	
-50D	80	x 80L	

Cylinder model	C	D	Mounting bolt part no.
CQ2WB32-5DZ	6.5	35	CQ-M5 x 35L
-10DZ		40	x 40L
-15DZ		45	x 45L
-20DZ		50	x 50L
-25DZ		55	x 55L
-30DZ		60	x 60L
-35DZ		65	x 65L
-40DZ		70	x 70L
-45DZ		75	x 75L
-50DZ		80	x 80L
-75DZ	115	x 115L	
-100DZ	140	x 140L	
CQ2WB40-5DZ	7	45	CQ-M5 x 45L
-10DZ		50	x 50L
-15DZ		55	x 55L
-20DZ		60	x 60L
-25DZ		65	x 65L
-30DZ		70	x 70L
-35DZ		75	x 75L
-40DZ		80	x 80L
-45DZ		85	x 85L
-50DZ		90	x 90L
-75DZ	125	x 125L	
-100DZ	150	x 150L	
CQ2WB50-10DZ	12.5	55	CQ-M6 x 55L
-15DZ		60	x 60L
-20DZ		65	x 65L
-25DZ		70	x 70L
-30DZ		75	x 75L
-35DZ		80	x 80L
-40DZ		85	x 85L
-45DZ		90	x 90L
-50DZ		95	x 95L
-75DZ		130	x 130L
-100DZ	155	x 155L	

Cylinder model	C	D	Mounting bolt part no.
CQ2WB63-10DZ	13.5	55	CQ-M8 x 55L
-15DZ		60	x 60L
-20DZ		65	x 65L
-25DZ		70	x 70L
-30DZ		75	x 75L
-35DZ		80	x 80L
-40DZ		85	x 85L
-45DZ		90	x 90L
-50DZ		95	x 95L
-75DZ		130	x 130L
-100DZ	155	x 155L	
CQ2WB80-10DZ	12.5	60	CQ-M10 x 60L
-15DZ		65	x 65L
-20DZ		70	x 70L
-25DZ		75	x 75L
-30DZ		80	x 80L
-35DZ		85	x 85L
-40DZ		90	x 90L
-45DZ		95	x 95L
-50DZ		100	x 100L
-75DZ		135	x 135L
-100DZ	160	x 160L	
CQ2WB100-10DZ	13	70	CQ-M10 x 70L
-15DZ		75	x 75L
-20DZ		80	x 80L
-25DZ		85	x 85L
-30DZ		90	x 90L
-35DZ		95	x 95L
-40DZ		100	x 100L
-45DZ		105	x 105L
-50DZ		110	x 110L
-75DZ		145	x 145L
-100DZ	170	x 170L	

Construction

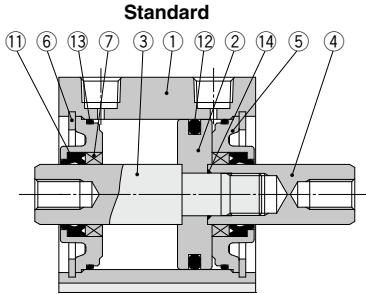

Component Parts

No.	Description	Material	Note
1	Cylinder tube	Aluminum alloy	Hard anodized
2	Piston	Aluminum alloy	
3	Piston rod A	Stainless steel	ø12 to ø25
		Carbon steel	ø32 to ø100, Hard chrome plated
4	Piston rod B	Stainless steel	ø12 to ø25
		Carbon steel	ø32 to ø100, Hard chrome plated
5	Collar	Aluminum alloy	ø12 to ø40, Anodized
		Aluminum alloy casted	ø50 to ø100, Chromated, Painted
6	Retaining ring	Carbon tool steel	Phosphate coated
7	Bushing	Bearing alloy	For ø50 or more only
8	Rod end nut	Carbon steel	Zinc chromated
9	Bumper	Urethane	
10	One-touch fitting	—	ø32 to ø63
11*	Rod seal	NBR	
12*	Piston seal	NBR	
13*	Tube gasket	NBR	
14	Piston gasket	NBR	

Replacement Parts/Seal Kit (Pneumatic type)

Bore size (mm)	Kit no.	Contents
12	CQ2WB12-PS	Kits include items ⑪, ⑫, ⑬ from the table.
16	CQ2WB16-PS	
20	CQ2WB20-PS	
25	CQ2WB25-PS	
32	CQ2WB32-PS	
40	CQ2WB40-PS	
50	CQ2WB50-PS	
63	CQ2WB63-PS	
80	CQ2WB80-PS	
100	CQ2WB100-PS	

* Seal kit includes ⑪, ⑫, ⑬. Order the seal kit, based on each bore size.

* Since the seal kit does not include a grease pack, order it separately.

Grease pack part no.: GR-S-010 (10 g)

With rubber bumper

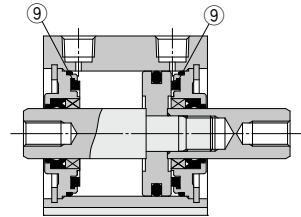

Built-in One-touch fittings

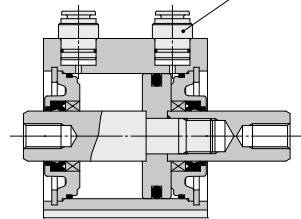

Rod end male thread

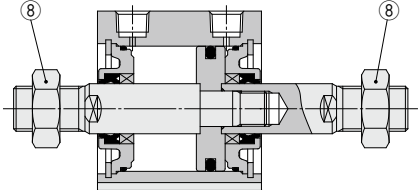

Replacement Parts/Seal Kit (Air-hydro type)

Bore size (mm)	Kit no.	Contents
20	CQ2WBH20-PS	Kits include items ⑪, ⑫, ⑬ from the table.
25	CQ2WBH25-PS	
32	CQ2WBH32-PS	
40	CQ2WBH40-PS	
50	CQ2WBH50-PS	
63	CQ2WBH63-PS	
80	CQ2WBH80-PS	
100	CQ2WBH100-PS	

* Seal kit includes ⑪, ⑫, ⑬. Order the seal kit, based on each bore size.

* Since the seal kit does not include a grease pack, order it separately.

Grease pack part no.: GR-S-010 (10 g)

CJ
CU
CQS
JCQ
CQ2
RQ
CQM
CQU
MU

D-□
-X□
Technical Data

Standard: Double Acting, Double Rod

CDQ2W Series

With Auto Switch



Refer to the below pages for further information on auto switches.

Auto switch proper mounting position and its mounting height	P.964 to 970
Minimum stroke for auto switch mounting	
Operating range	
Auto switch mounting brackets/Part no.	

Weight

Weight (g)

Bore size (mm)	Cylinder stroke (mm)											
	5	10	15	20	25	30	35	40	45	50	75	100
12	50	58	65	73	80	87	—	—	—	—	—	—
16	77	87	96	106	115	125	—	—	—	—	—	—
20	120	136	151	166	182	197	212	228	243	258	—	—
25	170	185	201	216	232	247	263	279	294	310	—	—
32	238	260	283	306	329	352	375	398	421	444	558	673
40	353	383	412	442	471	500	530	559	589	618	765	912
50	—	609	645	681	716	752	788	823	859	895	1073	1252
63	—	798	840	882	924	966	1008	1051	1093	1135	1346	1556
80	—	1393	1469	1546	1622	1699	1775	1851	1928	2004	2387	2769
100	—	2334	2443	2551	2660	2769	2877	2986	3094	3203	3746	4289

Additional Weight (g)

Bore size (mm)	12	16	20	25	32	40	50	63	80	100	
Both ends tapped	1	1	3	3	6	6	6	19	45	45	
Rod end male thread	Male thread	3	6	12	24	52	54	106	106	240	350
	Nut	2	4	8	16	34	34	64	64	98	232
With rubber bumper	0	0	-2	-2	-3	-7	-12	-19	-34	-54	
Built-in One-touch fittings	—	—	—	—	12	12	21	21	—	—	
Foot (Including mounting bolts)	52	65	153	177	158	170	267	342	722	1107	
Compact foot (Including mounting bolts)	32	40	97	116	99	114	177	241	501	770	
Flange (Including mounting bolts)	54	67	131	153	180	214	373	559	1056	1365	

Calculation: (Example) **CDQ2WF32-20DCMZ** Add each weight of auto switches when

- Basic weight: CDQ2WB32-20DZ 306 g auto switches when
- Additional weight: Both ends tapped 6 g auto switches are mounted.
- Rod end male thread 86 g
- With rubber bumper -3 g
- Rod flange 180 g

575 g

Construction

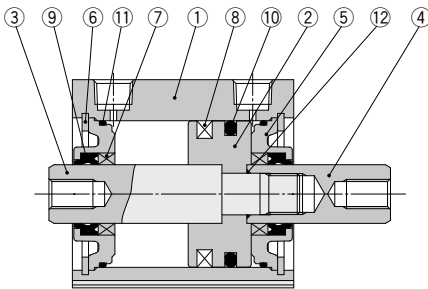

Component Parts

No.	Description	Material	Note
1	Cylinder tube	Aluminum alloy	Hard anodized
2	Piston	Aluminum alloy	
3	Piston rod A	Stainless steel	ø12 to ø25
		Carbon steel	ø32 to ø100, Hard chrome plated
4	Piston rod B	Stainless steel	ø12 to ø25
		Carbon steel	ø32 to ø100, Hard chrome plated
5	Collar	Aluminum alloy	ø12 to ø40, Anodized
6	Retaining ring	Aluminum alloy casted	ø50 to ø100, Chromated, Painted
7	Bushing	Carbon tool steel	Phosphate coated
8	Magnet	Bearing alloy	For ø50 or more only
9 ^{*)}	Rod seal	—	—
10 ^{*)}	Piston seal	NBR	
11 ^{*)}	Tube gasket	NBR	
12	Piston gasket	NBR	

Replacement Parts/Seal Kit (Pneumatic type)

Bore size (mm)	Kit no.	Contents
12	CQ2WB12-PS	Kits include items ⑨, ⑩, ⑪ from the table.
16	CQ2WB16-PS	
20	CQ2WB20-PS	
25	CQ2WB25-PS	
32	CQ2WB32-PS	
40	CQ2WB40-PS	
50	CQ2WB50-PS	
63	CQ2WB63-PS	
80	CQ2WB80-PS	
100	CQ2WB100-PS	

- * Seal kit includes ⑨, ⑩, ⑪. Order the seal kit, based on each bore size.
- * Since the seal kit does not include a grease pack, order it separately.
- * Grease pack part no.: GR-S-010 (10 g)

Replacement Parts/Seal Kit (Air-hydro type)

Bore size (mm)	Kit no.	Contents
20	CQ2WBH20-PS	Kits include items ⑨, ⑩, ⑪ from the table.
25	CQ2WBH25-PS	
32	CQ2WBH32-PS	
40	CQ2WBH40-PS	
50	CQ2WBH50-PS	
63	CQ2WBH63-PS	
80	CQ2WBH80-PS	
100	CQ2WBH100-PS	

- * Seal kit includes ⑨, ⑩, ⑪. Order the seal kit, based on each bore size.
- * Since the seal kit does not include a grease pack, order it separately.
- * Grease pack part no.: GR-S-010 (10 g)

Mounting Bolt for CDQ2WB/With Auto Switch

Mounting method: Mounting bolt for through-hole mounting of the CDQ2WB is available as an option. Refer to the following for ordering procedures. Order the actual number of bolts that will be used.

Example) CQ-M3 x 40L 2 pcs.

Material: Chromium molybdenum steel
Surface treatment: Zinc chromated

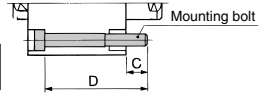

Cylinder model	C	D	Mounting bolt part no.
CDQ2WB12-5DCZ		40	CQ-M3 x 40L
-10DCZ	6.1	45	x 45L
-15DCZ		50	x 50L
-20DCZ		55	x 55L
-25DCZ		60	x 60L
-30DCZ		65	x 65L
CDQ2WB16-5DZ		45	CQ-M3 x 45L
-10DZ	7.5	50	x 50L
-15DZ		55	x 55L
-20DZ		60	x 60L
-25DZ		65	x 65L
-30DZ		70	x 70L
CDQ2WB20-5DZ		45	CQ-M5 x 45L
-10DZ	9	50	x 50L
-15DZ		55	x 55L
-20DZ		60	x 60L
-25DZ		65	x 65L
-30DZ		70	x 70L
-35DZ	75	x 75L	
-40DZ	80	x 80L	
-45DZ	85	x 85L	
-50DZ	90	x 90L	
CDQ2WB25-5DZ		45	CQ-M5 x 45L
-10DZ	8	50	x 50L
-15DZ		55	x 55L
-20DZ		60	x 60L
-25DZ		65	x 65L
-30DZ		70	x 70L
-35DZ	75	x 75L	
-40DZ	80	x 80L	
-45DZ	85	x 85L	
-50DZ	90	x 90L	

Cylinder model	C	D	Mounting bolt part no.
CDQ2WB32-5DZ		45	CQ-M5 x 45L
-10DZ	6.5	50	x 50L
-15DZ		55	x 55L
-20DZ		60	x 60L
-25DZ		65	x 65L
-30DZ		70	x 70L
-35DZ	75	x 75L	
-40DZ	80	x 80L	
-45DZ	85	x 85L	
-50DZ	90	x 90L	
-75DZ	115	x 115L	
-100DZ	140	x 140L	
CDQ2WB40-5DZ		55	CQ-M5 x 55L
-10DZ	7	60	x 60L
-15DZ		65	x 65L
-20DZ		70	x 70L
-25DZ		75	x 75L
-30DZ		80	x 80L
-35DZ	85	x 85L	
-40DZ	90	x 90L	
-45DZ	95	x 95L	
-50DZ	100	x 100L	
-75DZ	125	x 125L	
-100DZ	150	x 150L	
CDQ2WB50-10DZ		65	CQ-M6 x 65L
-15DZ	12.5	70	x 70L
-20DZ		75	x 75L
-25DZ		80	x 80L
-30DZ		85	x 85L
-35DZ		90	x 90L
-40DZ	95	x 95L	
-45DZ	100	x 100L	
-50DZ	105	x 105L	
-75DZ	130	x 130L	
-100DZ	155	x 155L	

Cylinder model	C	D	Mounting bolt part no.
CDQ2WB63-10DZ		65	CQ-M8 x 65L
-15DZ	13.5	70	x 70L
-20DZ		75	x 75L
-25DZ		80	x 80L
-30DZ		85	x 85L
-35DZ		90	x 90L
-40DZ	95	x 95L	
-45DZ	100	x 100L	
-50DZ	105	x 105L	
-75DZ	130	x 130L	
-100DZ	155	x 155L	
CDQ2WB80-10DZ		70	CQ-M10 x 70L
-15DZ	12.5	75	x 75L
-20DZ		80	x 80L
-25DZ		85	x 85L
-30DZ		90	x 90L
-35DZ		95	x 95L
-40DZ	100	x 100L	
-45DZ	105	x 105L	
-50DZ	110	x 110L	
-75DZ	135	x 135L	
-100DZ	160	x 160L	
CDQ2WB100-10DZ		80	CQ-M10 x 80L
-15DZ	13	85	x 85L
-20DZ		90	x 90L
-25DZ		95	x 95L
-30DZ		100	x 100L
-35DZ		105	x 105L
-40DZ	110	x 110L	
-45DZ	115	x 115L	
-50DZ	120	x 120L	
-75DZ	145	x 145L	
-100DZ	170	x 170L	

CUJ

CU

CQS

JCQ

CQ2

RQ

CQM

CQU

MU

D-□

-X□

Technical
Data

CQ2W Series

Dimensions

Ø12 to Ø25/Without Auto Switch

Standard (Through-hole): CQ2WB

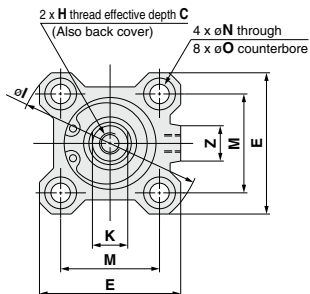

Both ends tapped: CQ2WA

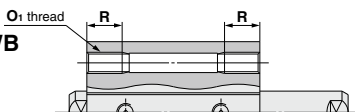

Both Ends Tapped

(mm)		
Bore size (mm)	O ₁	R
12	M4 x 0.7	7
16	M4 x 0.7	7
20	M6 x 1.0	10
25	M6 x 1.0	10

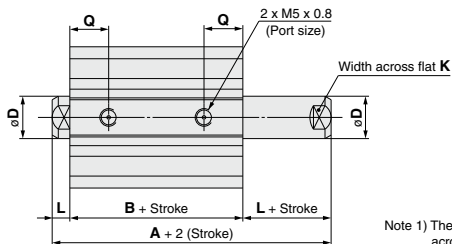

Note 1) The positions of left and right width across flats are not constant.

Rod end male thread

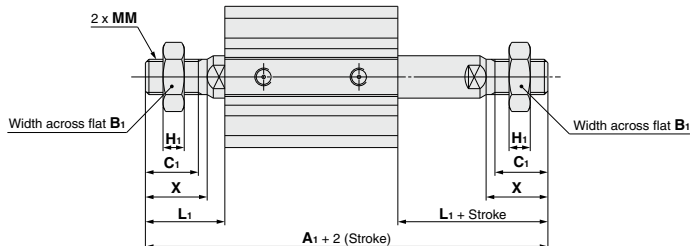

Rod End Male Thread

(mm)							
Bore size (mm)	A ₁	B ₁	C ₁	H ₁	L ₁	MM	X
12	53.2	8	9	4	14	M5 x 0.8	10.5
16	57	10	10	5	15.5	M6 x 1.0	12
20	63	13	12	5	18.5	M8 x 1.25	14
25	74	17	15	6	22.5	M10 x 1.25	17.5

Standard

(mm)															
Bore size (mm)	Stroke range (mm)	A	B	C	D	E	H	I	K	L	M	N	O	Q	Z
12	5 to 30	32.2	25.2	6	6	25	M3 x 0.5	32	5	3.5	15.5	3.5	6.5 depth 3.5	10	—
16	5 to 30	33	26	8	8	29	M4 x 0.7	38	6	3.5	20	3.5	6.5 depth 3.5	10	10
20	5 to 50	35	26	7	10	36	M5 x 0.8	47	8	4.5	25.5	5.5	9 depth 7	8	10
25	5 to 50	39	29	12	12	40	M6 x 1.0	52	10	5	28	5.5	9 depth 7	9	10

Note 2) The external dimensions with rubber bumper are same as those of the standard, as shown above.

* For details about the rod end nut and accessory brackets, refer to page 796.

Foot: CQ2WL

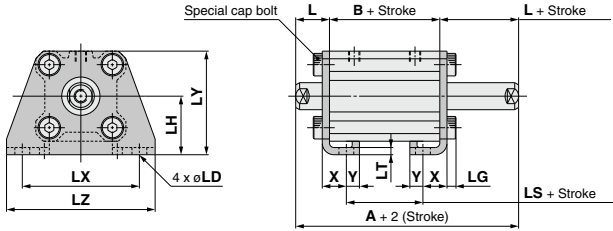

Note) The positions of left and right width across flats are not constant.

Rod end male thread

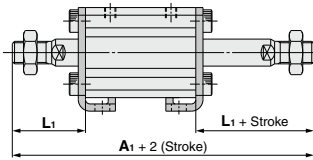

Rod End Male Thread (mm)

Bore size (mm)	A1	L1
12	73.2	24
16	77	25.5
20	83	28.5
25	94	32.5

Foot

(mm)

Bore size (mm)	Stroke range (mm)	A	B	L	LD	LG	LH	LS	LT	LX	LY	LZ	X	Y
12	5 to 30	52.2	25.2	13.5	4.5	2.8	17	13.2	2	34	29.5	44	8	4.5
16	5 to 30	53	26	13.5	4.5	2.8	19	14	2	38	33.5	48	8	5
20	5 to 50	55	26	14.5	6.6	4	24	14	3.2	48	42	62	9.2	5.8
25	5 to 50	59	29	15	6.6	4	26	14	3.2	52	46	66	10.7	5.8

Foot bracket material: Carbon steel
Surface treatment: Nickel plated

Compact foot: CQ2WLC

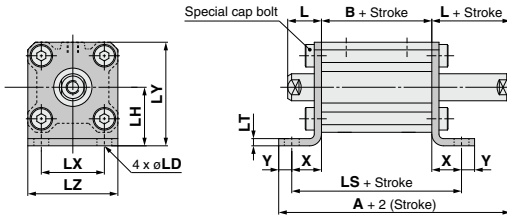

Note) The positions of left and right width across flats are not constant.

Rod end male thread

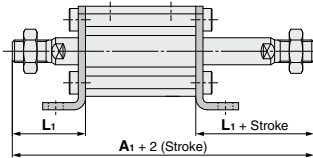

Rod End Male Thread (mm)

Bore size (mm)	A1	L1
12	73.2	24
16	77	25.5
20	83	28.5
25	94	32.5

Compact Foot

(mm)

Bore size (mm)	Stroke range (mm)	A	B	L	LD	LH	LS	LT	LX	LY	LZ	X	Y
12	5 to 30	52.5	25.2	13.5	4.5	17	43.8	2	15.5	29.5	25	9.3	4.5
16	5 to 30	53.8	26	13.5	4.5	19	44.6	2	20	33.5	29	9.3	5
20	5 to 50	59.5	26	14.5	6.6	24	52.4	3.2	25.5	42	36	13.2	5.8
25	5 to 50	63	29	15	6.6	26	55.4	3.2	28	46	40	13.2	5.8

* For details about the rod end nut and accessory brackets, refer to page 796.

Compact foot bracket material: Carbon steel
Surface treatment: Zinc chromated

CQ2W Series

Dimensions

Ø12 to Ø25/Without Auto Switch

Flange: CQ2WF

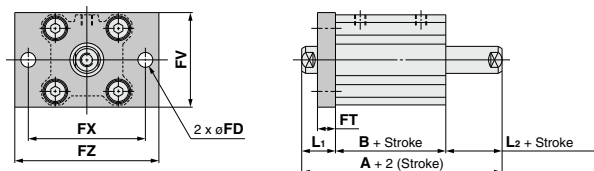

Note) The positions of left and right width across flats are not constant.

Rod end male thread

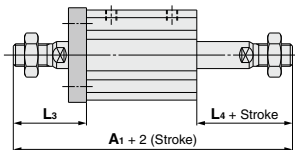

Rod End Male Thread

Bore size (mm)	A_1	L_3	L_4
12	63.2	24	14
16	67	25.5	15.5
20	73	28.5	18.5
25	84	32.5	22.5

Flange

Bore size (mm)	Stroke range (mm)	A	B	FD	FT	FV	FX	FZ	L_1	L_2
12	5 to 30	42.2	25.2	4.5	5.5	25	45	55	13.5	3.5
16	5 to 30	43	26	4.5	5.5	30	45	55	13.5	3.5
20	5 to 50	45	26	6.6	8	39	48	60	14.5	4.5
25	5 to 50	49	29	6.6	8	42	52	64	15	5

* For details about the rod end nut and accessory brackets, refer to page 796.

Flange bracket material: Carbon steel
Surface treatment: Nickel plated

Dimensions

Ø12 to Ø25/With Auto Switch

Both Ends Tapped

Bore size (mm)	O ₁	R
12	M4 x 0.7	7
16	M4 x 0.7	7
20	M6 x 1.0	10
25	M6 x 1.0	10

Both ends tapped: CDQ2WA

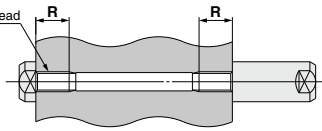

Standard (Through-hole): CDQ2WB

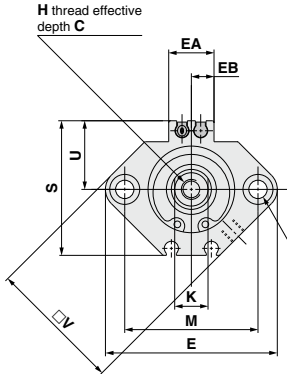

Ø16 to Ø25

Note 1) The positions of left and right width across flats are not constant.

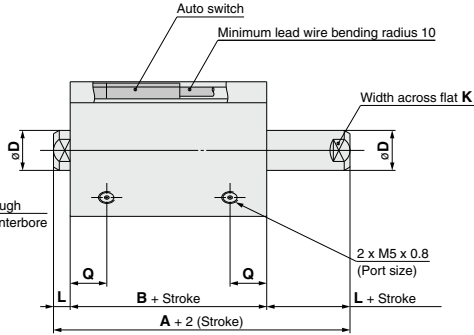

Rod end male thread

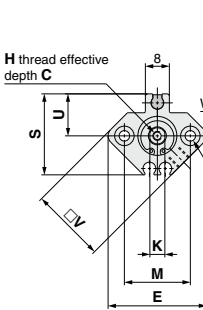

Ø12

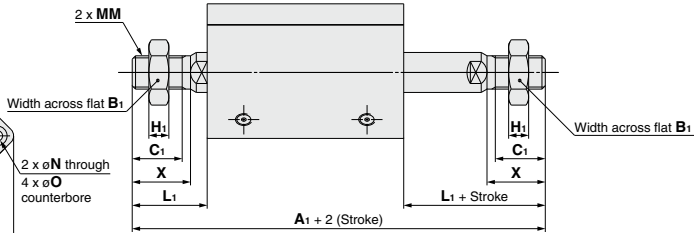

Rod End Male Thread

Bore size (mm)	A ₁	B ₁	C ₁	H ₁	L ₁	MM	X
12	60.4	8	9	4	14	M5 x 0.8	10.5
16	67	10	10	5	15.5	M6 x 1.0	12
20	75	13	12	5	18.5	M8 x 1.25	14
25	84	17	15	6	22.5	M10 x 1.25	17.5

Standard For auto switch proper mounting position and its mounting height, refer to pages 964 to 970.

Bore size (mm)	Stroke range (mm)	A	B	C	D	E	EA	EB	H	K	L	M	N	O	Q	S	U	V
12	5 to 30	39.4	32.4	6	6	33	—	—	M3 x 0.5	5	3.5	22	3.5	6.5 depth 3.5	10.5	27.5	14	25
16	5 to 30	43	36	8	8	37	13.2	6.6	M4 x 0.7	6	3.5	28	3.5	6.5 depth 3.5	10	29.5	15	29
20	5 to 50	47	38	7	10	47	13.6	6.8	M5 x 0.8	8	4.5	36	5.5	9 depth 7	8	35.5	18	36
25	5 to 50	49	39	12	12	52	13.6	6.8	M6 x 1.0	10	5	40	5.5	9 depth 7	9	40.5	21	40

Note 2) The external dimensions with rubber bumper are same as those of the standard, as shown above.
* For details about the rod end nut and accessory brackets, refer to page 796.

- CUJ
- CU
- CQS
- JCQ
- CQ2**
- RQ
- QCM
- QCU
- MU

- D-□
- X□
- Technical Data

CQ2W Series

Dimensions

Ø12 to Ø25/With Auto Switch

Foot: CDQ2WL

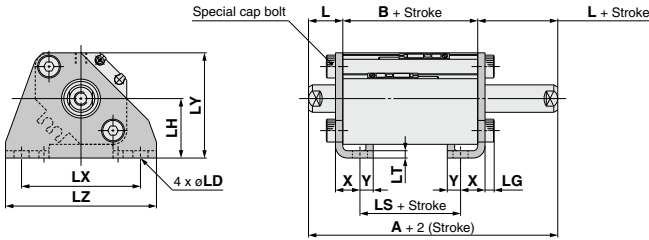

Note) The positions of left and right width across flats are not constant.

Rod end male thread

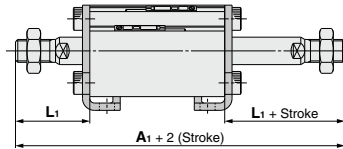

Rod End Male Thread

Bore size (mm)	A ₁	L ₁
12	80.4	24
16	87	25.5
20	95	28.5
25	104	32.5

Foot

Bore size (mm)	Stroke range (mm)	A	B	L	LD	LG	LH	LS	LT	LX	LY	LZ	X	Y
12	5 to 30	59.4	32.4	13.5	4.5	2.8	17	20.4	2	34	29.5	44	8	4.5
16	5 to 30	63	36	13.5	4.5	2.8	19	24	2	38	33.5	48	8	5
20	5 to 50	67	38	14.5	6.6	4	24	26	3.2	48	42	62	9.2	5.8
25	5 to 50	69	39	15	6.6	4	26	24	3.2	52	46	66	10.7	5.8

Foot bracket material: Carbon steel
Surface treatment: Nickel plated

Compact foot: CDQ2WLC

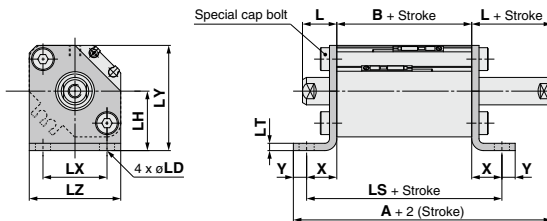

Note) The positions of left and right width across flats are not constant.

Rod end male thread

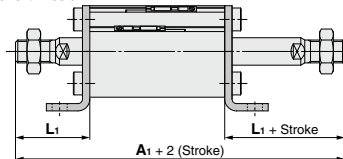

Rod End Male Thread

Bore size (mm)	A ₁	L ₁
12	80.4	24
16	87	25.5
20	95	28.5
25	104	32.5

Compact Foot

Bore size (mm)	Stroke range (mm)	A	B	L	LD	LH	LS	LT	LX	LY	LZ	X	Y
12	5 to 30	59.7	32.4	13.5	4.5	17	51	2	15.5	29.5	25	9.3	4.5
16	5 to 30	63.8	36	13.5	4.5	19	54.6	2	20	33.5	29	9.3	5
20	5 to 50	71.5	38	14.5	6.6	24	64.4	3.2	25.5	42	36	13.2	5.8
25	5 to 50	73	39	15	6.6	26	65.4	3.2	28	46	40	13.2	5.8

* For details about the rod end nut and accessory brackets, refer to page 796.

Compact foot bracket material: Carbon steel
Surface treatment: Zinc chromated

Flange: CDQ2WF

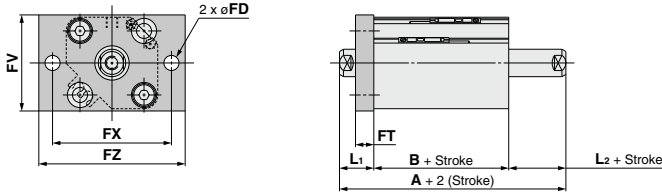

Note) The positions of left and right width across flats are not constant.

Rod end male thread

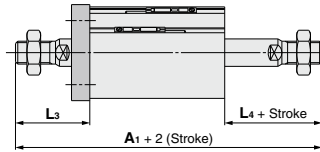

Rod End
Male Thread

Bore size (mm)	A ₁	L ₃	L ₄
12	70.4	24	14
16	77	25.5	15.5
20	85	28.5	18.5
25	94	32.5	22.5

Flange

Bore size (mm)	Stroke range (mm)	A	B	FD	FT	FV	FX	FZ	L ₁	L ₂
12	5 to 30	49.4	32.4	4.5	5.5	25	45	55	13.5	3.5
16	5 to 30	53	36	4.5	5.5	30	45	55	13.5	3.5
20	5 to 50	57	38	6.6	8	39	48	60	14.5	4.5
25	5 to 50	59	39	6.6	8	42	52	64	15	5

* For details about the rod end nut and accessory brackets, refer to page 796.

Flange bracket material: Carbon steel
Surface treatment: Nickel plated

- CUJ
- CU
- CQS
- JCQ
- CQ2**
- RQ
- QCM
- QCU
- MU

- D-□
- X□
- Technical Data

CQ2W Series

Dimensions

Ø32 to Ø50/With Auto Switch

(In the case of without auto switches, the A, B and P dimensions will be only changed. Refer to the dimension table.)

Standard (Through-hole): CQ2WB/CDQ2WB

Both ends tapped: CQ2WA/CDQ2WA

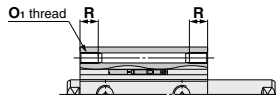

Both Ends Tapped

Bore size (mm)	O1	R
32	M6 x 1.0	10
40	M6 x 1.0	10
50	M8 x 1.25	14

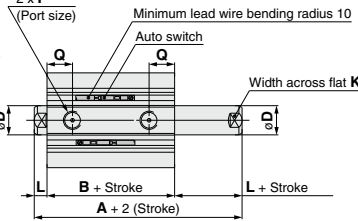
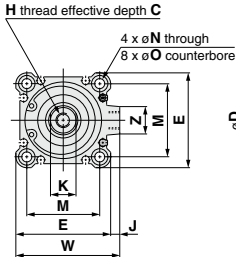

Note 1) The positions of left and right width across flats are not constant.

Rod end male thread

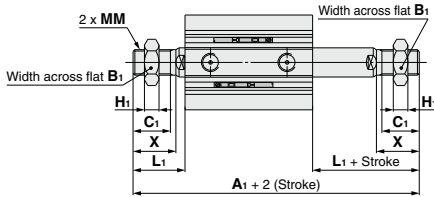

Rod End Male Thread

Bore size (mm)	Stroke range (mm)	Without auto switch		With auto switch	
		A1	A1	A1	A1
32	5				
	10 to 50	87.5			
	75, 100		97.5		97.5
40	5 to 50	97			107
	75, 100		107		
50	10 to 50	107.5			117.5
	75, 100		117.5		

Bore size (mm)	B1	C1	H1	L1	MM	X
32	22	20.5	8	28.5	M14 x 1.5	23.5
40	22	20.5	8	28.5	M14 x 1.5	23.5
50	27	26	11	33.5	M18 x 1.5	28.5

Built-in One-touch fittings: Ø32 to Ø50

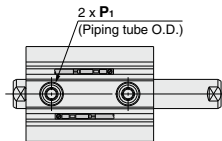
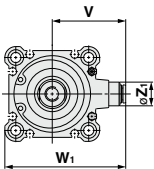

Built-in One-touch Fittings

Bore size (mm)	Without auto switch		With auto switch		Z1	P1
	V	W1	V	W1		
32	38	60.5	36.5	59	13	6
40	42	68	40.5	66.5	13	6
50	50	82	50	82	16	8

Standard

For auto switch proper mounting position and its mounting height, refer to pages 964 to 970.

Bore size (mm)	Stroke range (mm)	Without auto switch						With auto switch		
		A	B	P	A	B	P			
32	5									
	10 to 50	44.5	30.5	M5						
	75, 100	54.5	40.5	1/8	54.5	40.5	1/8			
40	5 to 50	54	40							
	75, 100	64	50	1/8	64	50	1/8			
50	10 to 50	56.5	40.5							
	75, 100	66.5	50.5	1/4	66.5	50.5	1/4			

Bore size (mm)	C	D	E	H	J	K	L	M	N	O	Q	W	Z
32	13	16	45	M8 x 1.25	4.5	14	7	34	5.5	9 depth 7	10	49.5	14
40	13	16	52	M8 x 1.25	5	14	7	40	5.5	9 depth 7	12.5	57	15
50	15	20	64	M10 x 1.5	7	17	8	50	6.6	11 depth 8	14	71	19

Note 2) The external dimensions with rubber bumper are same as those of the standard, as shown above.

* For details about the rod end nut and accessory brackets, refer to page 796.

Foot: CQ2WL/CDQ2WL

(Note) The positions of left and right width across flats are not constant.

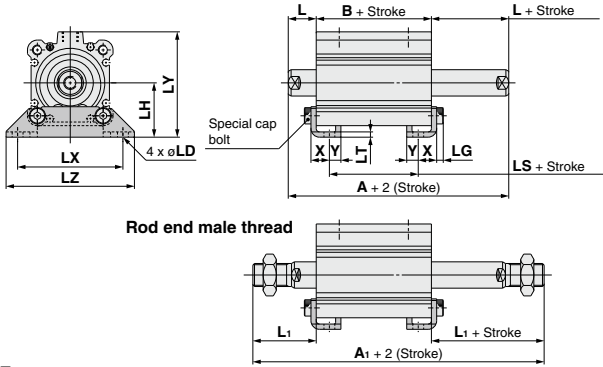

Rod End Male Thread (mm)

Bore size (mm)	Stroke range (mm)	Without auto switch A ₁	With auto switch A ₁	L ₁
32	5 to 50	107.5		
	75, 100	117.5	117.5	38.5
40	5 to 50	117		
	75, 100	127	127	38.5
50	10 to 50	127.5		
	75, 100	137.5	137.5	43.5

Foot

Bore size (mm)	Stroke range (mm)	Without auto switch			With auto switch		
		A	B	LS	A	B	LS
32	5 to 50	64.5	30.5	14.5	74.5	40.5	24.5
	75, 100	74.5	40.5	24.5			
40	5 to 50	74	40	24	84	50	34
	75, 100	84	50	34			
50	10 to 50	76.5	40.5	17.5	86.5	50.5	27.5
	75, 100	86.5	50.5	27.5			

Bore size (mm)	L	LD	LG	LH	LT	LX	LY	LZ	X	Y
32	17	6.6	4	30	3.2	57	57	71	11.2	5.8
40	17	6.6	4	33	3.2	64	64	78	11.2	7
50	18	9	5	39	3.2	79	78	95	14.7	8

Foot bracket material: Carbon steel
Surface treatment: Nickel plated

Compact foot: CQ2WLC/CDQ2WLC

(Note) The positions of left and right width across flats are not constant.

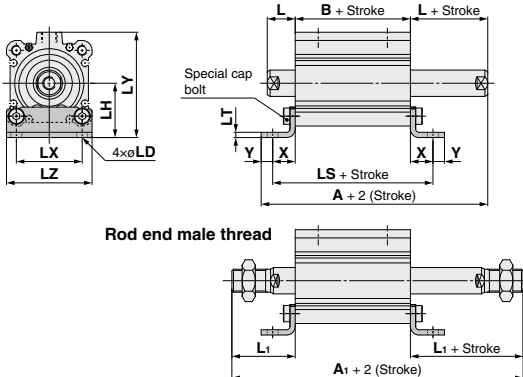

Rod End Male Thread (mm)

Bore size (mm)	Stroke range (mm)	Without auto switch A ₁	With auto switch A ₁	L ₁
32	5 to 50	107.5		
	75, 100	117.5	117.5	38.5
40	5 to 50	117		
	75, 100	127	127	38.5
50	10 to 50	127.5		
	75, 100	137.5	137.5	43.5

Compact Foot

Bore size (mm)	Stroke range (mm)	Without auto switch			With auto switch			(mm)									
		A	B	LS	A	B	LS	L	LD	LH	LT	LX	LY	LZ	X	Y	
32	5 to 50	67	30.5	57.9	77	40.5	67.9	17	6.6	30	3.2	34	57	45	13.7	5.8	
	75, 100	77	40.5	67.9													
40	5 to 50	77.7	40	67.4	87.7	50	77.4	17	6.6	33	3.2	40	64	52	13.7	7	
	75, 100	87.7	50	77.4													
50	10 to 50	83.2	40.5	73.9	93.2	50.5	83.9	18	9	39	3.2	50	78	64	16.7	8	
	75, 100	93.2	50.5	83.9													

Compact foot bracket material: Carbon steel
Surface treatment: Zinc chromated

- CJ
- CU
- CQS
- JCQ
- CQ2**
- RQ
- CQM
- CQU
- MU

- D-□
- X□

Technical Data

CQ2W Series

Dimensions

Ø32 to Ø50/With Auto Switch

(In the case of without auto switches, the A, B and P dimensions will be only changed. Refer to the dimension table.)

Flange: CQ2WF/CDQ2WF

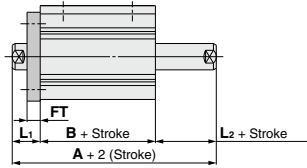
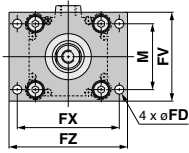

Note) The positions of left and right width across flats are not constant.

Rod end male thread

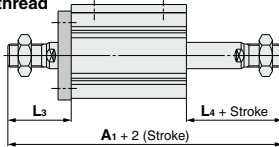

Rod End Male Thread

(mm)

Bore size (mm)	Stroke range (mm)	Without auto switch	With auto switch	L ₃	L ₄
		A ₁	A ₁		
32	5 to 50	97.5	107.5	38.5	28.5
	75, 100	107.5			
40	5 to 50	107	117	38.5	28.5
	75, 100	117			
50	10 to 50	117.5	127.5	43.5	33.5
	75, 100	127.5			

Flange

(mm)

Bore size (mm)	Stroke range (mm)	Without auto switch		With auto switch		FD	FT	FV	FX	FZ	L ₁	L ₂	M
		A	B	A	B								
32	5 to 50	54.5	30.5	64.5	40.5	5.5	8	48	56	65	17	7	34
	75, 100	64.5	40.5										
40	5 to 50	64	40	74	50	5.5	8	54	62	72	17	7	40
	75, 100	74	50										
50	10 to 50	66.5	40.5	76.5	50.5	6.6	9	67	76	89	18	8	50
	75, 100	76.5	50.5										

Flange bracket material: Carbon steel
Surface treatment: Nickel plated

Dimensions

ø63 to ø100/With Auto Switch

(In the case of without auto switches, the A and B dimensions will be only changed. Refer to the dimension table.)

Both ends tapped: CQ2WA/CDQ2WA

Both Ends Tapped (mm)

Bore size (mm)	O ₁	R
63	M10 x 1.5	18
80	M12 x 1.75	22
100	M12 x 1.75	22

Standard (Through-hole): CQ2WB/CDQ2WB

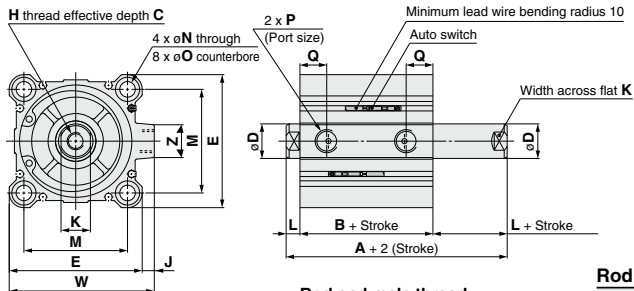
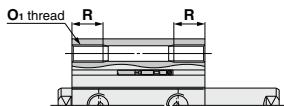

Note 1) The positions of left and right width across flats are not constant.

Rod End Male Thread (mm)

Bore size (mm)	Stroke range (mm)	Without auto switch		With auto switch	
		A	A ₁	A	A ₁
63	10 to 50	109		119	
	75, 100	119			
80	10 to 50	138		148	
	75, 100	148			
100	10 to 50	147.5		157.5	
	75, 100	157.5			

Rod end male thread

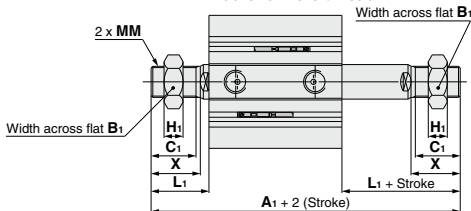

(mm)

Bore size (mm)	B ₁	C ₁	H ₁	L ₁	MM	X
63	27	26	11	33.5	M18 x 1.5	28.5
80	32	32.5	13	43.5	M22 x 1.5	35.5
100	41	32.5	16	43.5	M26 x 1.5	35.5

Built-in One-touch fittings

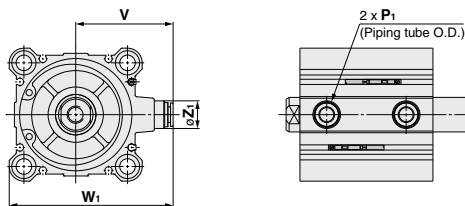

Built-in One-touch Fittings (mm)

Bore size (mm)	Z ₁	P ₁	V	W ₁
63	16	8	58.5	95

* The dimension of the ø32.5 mm stroke with built-in One-touch fittings is the same as that of the 10 mm stroke cylinder tube.

For auto switch proper mounting position and its mounting height, refer to pages 964 to 970. (mm)

Bore size (mm)	Stroke range (mm)	Without auto switch		With auto switch	
		A	B	A	B
63	10 to 50	58	42	68	52
	75, 100	68	52		
80	10 to 50	71	51	81	61
	75, 100	81	61		
100	10 to 50	84.5	60.5	94.5	70.5
	75, 100	94.5	70.5		

Bore size (mm)	C	D	E	H	J	K	L	M	N	O	P	Q	W	Z
63	15	20	77	M10 x 1.5	7	17	8	60	9	14 depth 10.5	1/4	15.5	84	19
80	21	25	98	M16 x 2.0	6	22	10	77	11	17.5 depth 13.5	3/8	18	104	25
100	27	30	117	M20 x 2.5	6.5	27	12	94	11	17.5 depth 13.5	3/8	22	123.5	25

Note 2) The external dimensions with rubber bumper are same as those of the standard, as shown above.

* For details about the rod end nut and accessory brackets, refer to page 796.

CUJ

CU

CQS

JCQ

CQ2

RQ

CQM

CQU

MU

D-□

-X□

Technical Data

CQ2W Series

Dimensions

Ø63 to Ø100/With Auto Switch

(In the case of without auto switches, the A and B dimensions will be only changed. Refer to the dimension table.)

Foot: CQ2WL/CDQ2WL

Note) The positions of left and right width across flats are not constant.

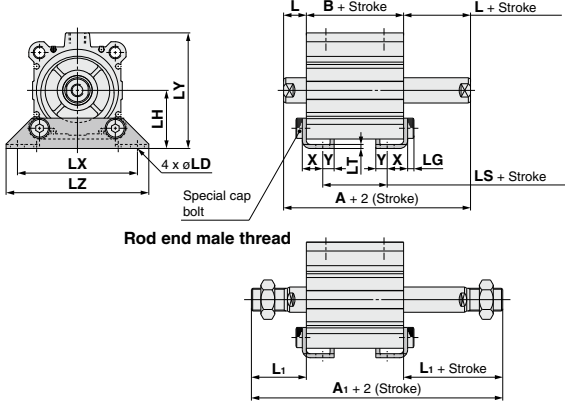

Rod End Male Thread (mm)

Bore size (mm)	Stroke range (mm)	Without auto switch	With auto switch	L ₁
		A ₁	A ₁	
63	10 to 50	129	139	43.5
	75, 100	139	139	
80	10 to 50	158	168	53.5
	75, 100	168	168	
100	10 to 50	167.5	177.5	53.5
	75, 100	177.5	177.5	

Foot

Bore size (mm)	Stroke range (mm)	Without auto switch			With auto switch			L	LD	LG	LH	LT	LX	LY	LZ	X	Y
		A	B	LS	A	B	LS										
63	10 to 50	78	42	16	88	52	26	18	11	5	46	3.2	95	91.5	113	16.2	9
	75, 100	88	52	26													
80	10 to 50	91	51	21	101	61	31	20	13	7	59	4.5	118	114	140	19.5	11
	75, 100	101	61	31													
100	10 to 50	104.5	60.5	26.5	114.5	70.5	36.5	22	13	7	71	6	137	136	162	23	12.5
	75, 100	114.5	70.5	36.5													

Foot bracket material: Carbon steel
Surface treatment: Nickel plated

Compact foot: CQ2WLC/CDQ2WLC

Note) The positions of left and right width across flats are not constant.

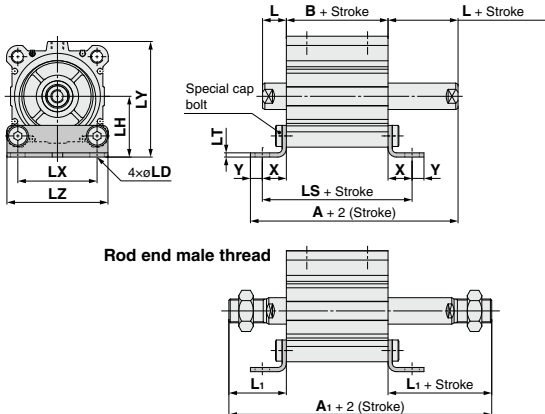

Rod End Male Thread (mm)

Bore size (mm)	Stroke range (mm)	Without auto switch	With auto switch	L ₁
		A ₁	A ₁	
63	10 to 50	129	139	43.5
	75, 100	139	139	
80	10 to 50	158	168	53.5
	75, 100	168	168	
100	10 to 50	167.5	177.5	53.5
	75, 100	177.5	177.5	

Compact Foot

Bore size (mm)	Stroke range (mm)	Without auto switch			With auto switch			L	LD	LH	LT	LX	LY	LZ	X	Y
		A	B	LS	A	B	LS									
63	10 to 50	87.2	42	78.4	97.2	52	88.4	18	11	46	3.2	60	91.5	77	18.2	9
	75, 100	97.2	52	88.4												
80	10 to 50	104.5	51	96	114.5	61	106	20	13	59	4.5	77	114	98	22.5	11
	75, 100	114.5	61	106												
100	10 to 50	119	60.5	108.5	129	70.5	118.5	22	13	71	6	94	136	117	24	12.5
	75, 100	129	70.5	118.5												

Compact foot bracket material: Carbon steel
Surface treatment: Zinc chromated

Flange: CQ2WF/CDQ2WF

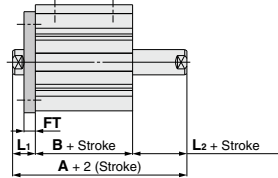
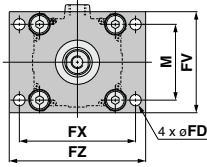

Note) The positions of left and right width across flats are not constant.

Rod end male thread

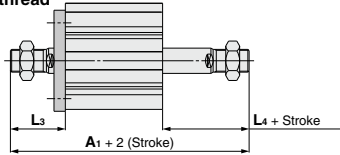

Rod End Male Thread (mm)

Bore size (mm)	Stroke range (mm)	Without auto switch	With auto switch	L ₃	L ₄
63	10 to 50	A ₁	A ₁	43.5	33.5
	75, 100	119	129		
80	10 to 50	148	158	53.5	43.5
	75, 100	158	167.5		
100	10 to 50	157.5	167.5	53.5	43.5
	75, 100	167.5	167.5		

Flange (mm)

Bore size (mm)	Stroke range (mm)	Without auto switch		With auto switch		FD	FT	FV	FX	FZ	L ₁	L ₂	M
		A	B	A	B								
63	10 to 50	68	42	78	52	9	9	80	92	108	18	8	60
	75, 100	78	52										
80	10 to 50	81	51	91	61	11	11	99	116	134	20	10	77
	75, 100	91	61										
100	10 to 50	94.5	60.5	104.5	70.5	11	11	117	136	154	22	12	94
	75, 100	104.5	70.5										

Flange bracket material: Carbon steel
Surface treatment: Nickel plated

CUJ

CU

CQS

JCQ

CQ2

RQ

CQM

CQU

MU

D-□

-X□

Technical Data