

**Remote Type**

# Pressure Sensor/ 3-Screen Display Sensor Monitor

**New**



**Pressure Sensor for General Fluids PSE57□ Series**

**Rated pressure range**

0 to 1 MPa

-100 to 100 kPa

0 to 500 kPa

0 to 2 MPa

0 to 5 MPa

0 to 10 MPa

**Withstand voltage 500 VAC**

<Twice that of the PSE560>

**Materials of Parts in Contact with Fluid**

Piping port	C3604 + Nickel plating
Pressure sensor	Al <sub>2</sub> O <sub>3</sub> (Alumina 96%)
Square ring	FKM



**New 3-Screen Display Sensor Monitor PSE300AC Series**

It is possible to change the settings while checking the measured value.



**Main screen**

Measured value (Current pressure value)

**Sub screen**

Label (Display item),

Set value (Threshold value)

**Visualization of Settings**

Set value (Threshold value)	P.1
Hysteresis value	H.1
Delay time	dt.1
Peak value	H.H.
Bottom value	H.Lo

**PSE57□/PSE300AC Series**



CAT.ES100-119A ©

# Pressure Sensor for General Fluids PSE57□ Series

## ● PSE570/573/574 (1 MPa/100 kPa/500 kPa)

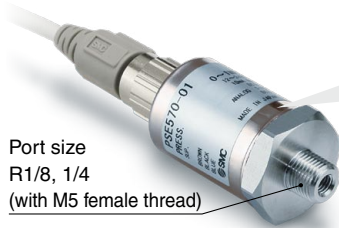

Port size  
R1/8, 1/4  
(with M5 female thread)

Materials of parts in contact with fluid

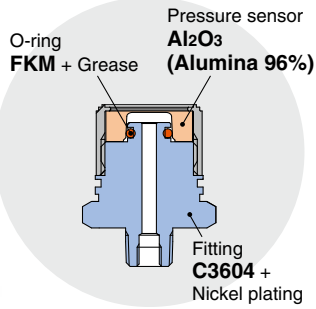

### Series Variations

Model	Rated pressure range								Proof pressure
	-100 kPa	0	100 kPa	500 kPa	1 MPa	2 MPa	5 MPa	10 MPa	
PSE570			1 MPa						3.0 MPa
PSE573	±100 kPa								600 kPa
PSE574			500 kPa						1.5 MPa

## ● PSE575/576/577 (2 MPa/5 MPa/10 MPa)

Port size  
R1/4 (with M5 female thread)



Materials of parts in contact with fluid

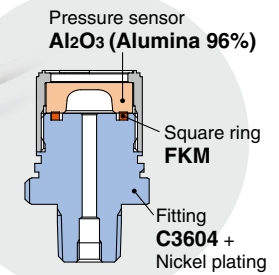

### Series Variations

Model	Rated pressure range								Proof pressure
	-100 kPa	0	100 kPa	500 kPa	1 MPa	2 MPa	5 MPa	10 MPa	
PSE575			2 MPa						5.0 MPa
PSE576					5 MPa				12.5 MPa
PSE577						10 MPa			30 MPa

## ● Reduced Work-hours & Required Installation Space for Piping

<Remote type>

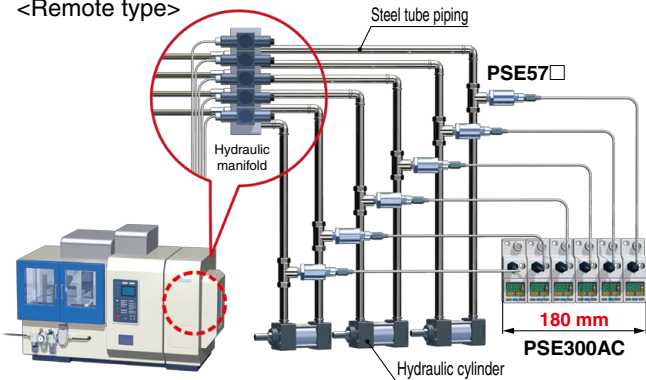

<Integrated type>

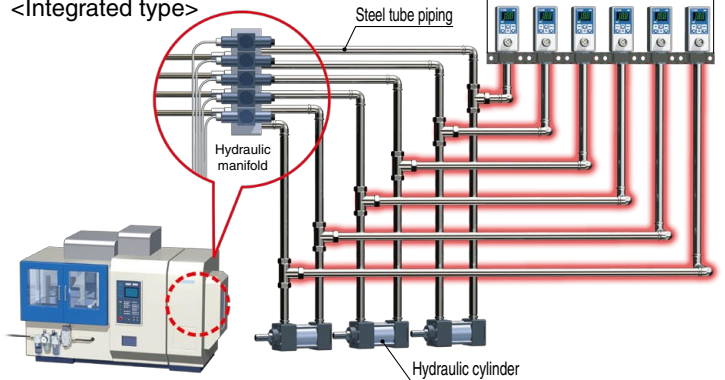

### Liquid coolant pressure control

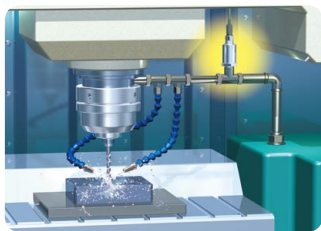

Suction verification of workpieces containing moisture

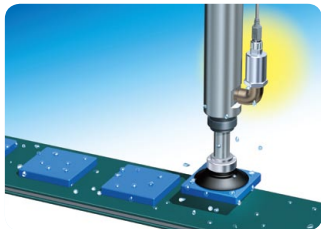

### Discharge pressure control for compressors



\* When vacuum is released, take precautions to avoid water hammer. (An adapter with restrictor (ZS-31-X175) is available to prevent water hammer.) (Refer to "NOTE" in the Operation Manual on the SMC website for details.)

### PET bottle molding machines

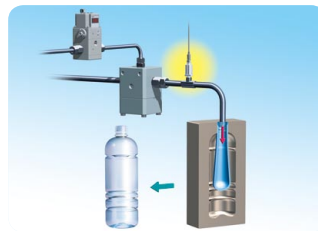

### Liquid pressure control of gun drills

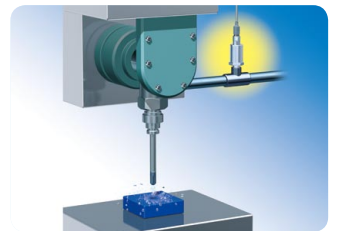

## Variations For details, refer to the Web Catalog.

### For General Fluids



### PSE56□ Series

- Wetted parts: Stainless steel 316L
- IP65
- Oil-free (Single diaphragm construction)

### Applicable Pressure Sensors

■ Compact Pneumatic Pressure Sensor

PSE53□



PSE54□



PSE55□



■ Low Differential Pressure Sensor

■ Pressure Sensor for General Fluids

PSE56□



# 3-Screen Display Sensor Monitor PSE300AC Series

## ● Visualization of Settings

The sub screen (label) shows the item to be set.

**New PSE300AC**



### Mode Examples

#### Hysteresis mode

Normal output (Threshold value)    Reverse output (Threshold value)

P\_1 0.500    r\_1 0.500

Hysteresis (Set hysteresis value)

H\_1 0.050

#### Window comparator mode

Normal output/Lo side (Threshold value)    Normal output/Hi side (Threshold value)

P\_L 0.300    P\_H 0.600

Reverse output/Lo side (Threshold value)    Reverse output/Hi side (Threshold value)

r\_L 0.300    r\_H 0.600

## ● Easy Screen Switching

It is possible to change the settings while checking the measured value.

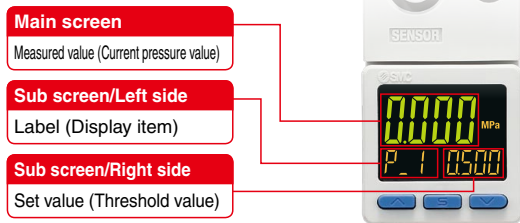

The sub screen can be switched by pressing the up/down buttons.

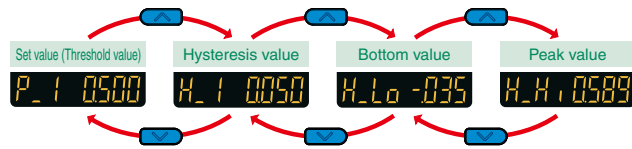

\* One arbitrary display mode can be added via function settings.

## ● NPN/PNP Switch Function

The number of stock items can be reduced.

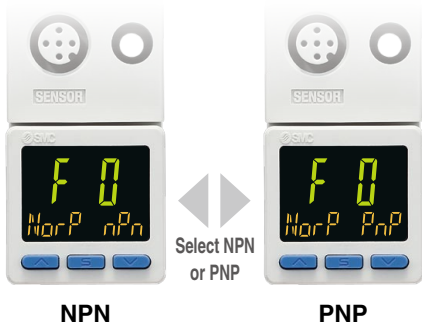

## ● Input Range Selection (for Pressure/Flow rate)

The sensor input range can be set to the required value and displayed.

(Voltage input: 1 to 5 V/Current input: 4 to 20 mA)

Pressure switch/Flow switch can be displayed.

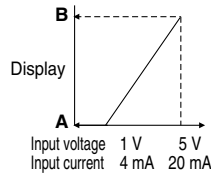

A is displayed for 1 V (or 4 mA).  
B is displayed for 5 V (or 20 mA).  
The range can be set as required.

### ■ For Digital Flow Switch for Water/PF3W511

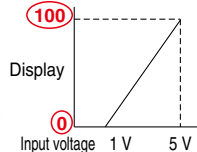

	A	B
PF3W504	0	4
PF3W520	0	16
PF3W540	0	40
PF3W511	0	100

Set A and B to the values shown in the table above.

## ● Simple 3-Step Setting

When the S button is pressed and the set value (P\_1) is being displayed, the set value (threshold value) can be set.  
When the S button is pressed and the hysteresis (H\_1) is being displayed, the hysteresis value can be set.

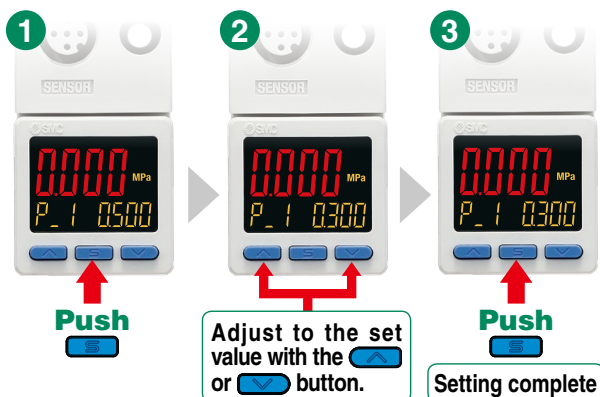

### With a snapshot function for set value reading

Pressing the up and down buttons for a minimum of 1 second will make the set value (threshold value) the same as the current pressure value.

**Snap shot function**

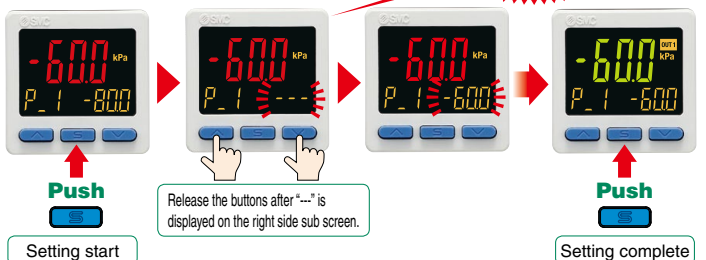

# Pressure Sensor for General Fluids

# PSE57□ Series



## How to Order

PSE57 0 - 01 - □ - □

### Sensor range

0	Positive pressure [0 to 1 MPa]
3	Compound pressure [-100 to 100 kPa]
4	Positive pressure [0 to 500 kPa]
5	Positive pressure [0 to 2 MPa]
6	Positive pressure [0 to 5 MPa]
7	Positive pressure [0 to 10 MPa]

### Option (Lead wire)

Nil	Lead wire and M12 connector (3 m), Straight	
L	Lead wire and M12 connector (3 m), Right angle	
N	None	

\* See page 9 for connection to the PSE300AC.

### Output specification

Nil	Voltage output type 1 to 5 V
28	Current output type 4 to 20 mA

### Port size

Symbol	Port size	Model					
		PSE570	PSE573	PSE574	PSE575	PSE576	PSE577
01	R1/8 (with M5 female thread)	●	●	●	—	—	—
02	R1/4 (with M5 female thread)	●	●	●	●	●	●

## Options/Part Nos.

Description	Part no.	Note
Lead wire and M12 connector (3 m), Straight	ZS-37-A	1 pc.
Lead wire and M12 connector (3 m), Right angle	ZS-37-B	1 pc.
Adapter with restrictor Rc1/4	ZS-31-X175	1 pc.
Adapter with restrictor Rc1/8	ZS-31-X188	1 pc.
Assembly-type connector	PCA-1557743	1 pc.

For pressure switch precautions and specific product precautions, refer to the "Operation Manual" on the SMC website.

## Specifications

Model		PSE570	PSE573	PSE574	PSE575	PSE576	PSE577
<b>Fluid</b>	<b>Applicable fluid</b>	Gas or liquid that will not corrode the materials of parts in contact with fluid					
<b>Pressure</b>	<b>Rated pressure range</b>	0 to 1 MPa	-100 to 100 kPa	0 to 500 kPa	0 to 2 MPa	0 to 5 MPa	0 to 10 MPa
	<b>Proof pressure</b>	3.0 MPa	600 kPa	1.5 MPa	5.0 MPa	12.5 MPa	30 MPa
	<b>Power supply voltage</b>	12 to 24 VDC ±10% with 10% voltage ripple or less					
<b>Electrical</b>	<b>Current consumption</b>	10 mA or less					
	<b>Protection</b>	Reverse connection protection					
	<b>Analog output accuracy (Ambient temperature of 25°C)</b>	±1.0% F.S.			±2.5% F.S.		
<b>Accuracy</b>	<b>Linearity</b>	±0.5% F.S.					
	<b>Repeatability (Ambient temperature of 25°C)</b>	±0.2% F.S.					±0.5% F.S.
	<b>Temperature characteristics (25°C reference)</b>	±2% F.S. (0 to 50°C) ±3% F.S. (-10 to 60°C)	±3% F.S. (0 to 50°C) ±4% F.S. (-10 to 60°C)		±5% F.S. (-10 to 60°C)		
<b>Environment</b>	<b>Enclosure</b>	IP65					
	<b>Withstand voltage</b>	500 VAC for 1 minute between terminals and housing					
	<b>Insulation resistance</b>	100 MΩ or more (500 VDC measured via megohmmeter) between terminals and housing					
	<b>Operating temperature range</b>	Operating: -10 to 60°C, Stored: -20 to 70°C (No freezing or condensation)					
	<b>Operating humidity range</b>	Operating/Stored: 35 to 85% RH (No condensation)					
<b>Standards</b>		CE, RoHS					
<b>Materials of parts in contact with fluid</b>		Piping port: C3604 + Nickel plating, Pressure sensor: Al <sub>2</sub> O <sub>3</sub> (Alumina 96%), O-ring: FKM + Grease			Piping port: C3604 + Nickel plating, Pressure sensor: Al <sub>2</sub> O <sub>3</sub> (Alumina 96%), Square ring: FKM		
<b>Analog output</b>	<b>Model</b>	PSE57□-□				PSE57□-□-28	
	<b>Output</b>	Voltage output: 1 to 5 V				Current output: 4 to 20 mA	
	<b>Impedance</b>	Output impedance: Approx. 1 kΩ				Maximum load impedance: 500 Ω or less (at 24 VDC) 100 Ω or less (at 12 VDC)	

## Piping Specifications

Part no.		PSE570/573/574-01	PSE570/573/574-02	PSE575/576/577-02
<b>Port size</b>		R1/8 M5 x 0.8	R1/4 M5 x 0.8	R1/4 M5 x 0.8
<b>Materials of parts in contact with fluid</b>		Piping port: C3604 + Nickel plating Pressure sensor: Al <sub>2</sub> O <sub>3</sub> (Alumina 96%) O-ring: FKM + Grease		Piping port: C3604 + Nickel plating Pressure sensor: Al <sub>2</sub> O <sub>3</sub> (Alumina 96%) Square ring: FKM
<b>Weight</b>	Without lead wire and M12 connector	88 g	95 g	103 g
	With lead wire and M12 connector	175 g	182 g	191 g

## Internal Circuits and Wiring Examples

### PSE57-□-□

Voltage output type  
1 to 5 V  
Output impedance  
Approx. 1 kΩ

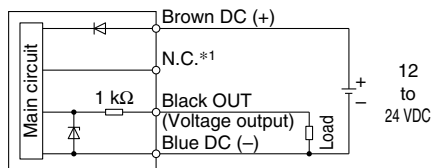

### PSE57-□-□-28

Current output type  
4 to 20 mA  
Allowable load impedance  
500 Ω or less (at 24 VDC)  
100 Ω or less (at 12 VDC)

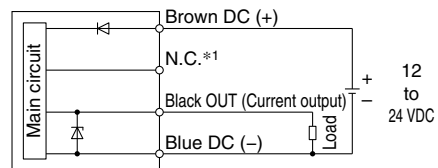

\*1 The unconnected terminals are only used by SMC, so please do not connect them.

## Analog Output

### 1 to 5 VDC

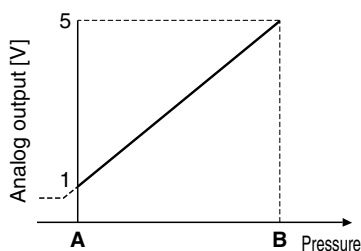

### 4 to 20 mA DC

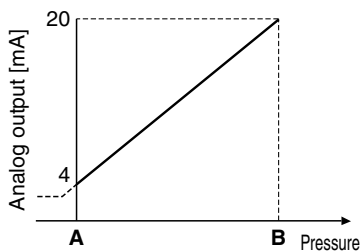

Model	Rated pressure range	A	B
PSE570	0 to 1 MPa	0 MPa	1 MPa
PSE573	-100 to 100 kPa	-100 kPa	100 kPa
PSE574	0 to 500 kPa	0 kPa	500 kPa
PSE575	0 to 2 MPa	0 MPa	2 MPa
PSE576	0 to 5 MPa	0 MPa	5 MPa
PSE577	0 to 10 MPa	0 MPa	10 MPa

## Dimensions

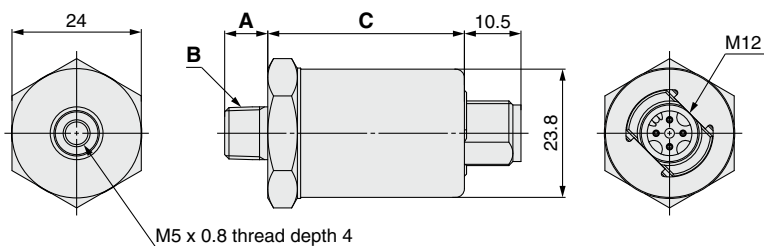

Part no.	A	B	C
PSE570/573/574-01	8	R1/8	36.5
PSE570/573/574-02	12	R1/4	36.5
PSE575/576/577-02	12	R1/4	39.7

## Lead wire and M12 connector

### ZS-37-A

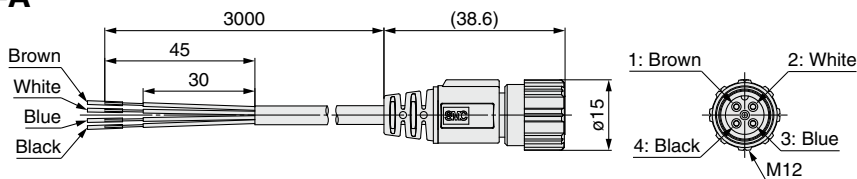

### ZS-37-B

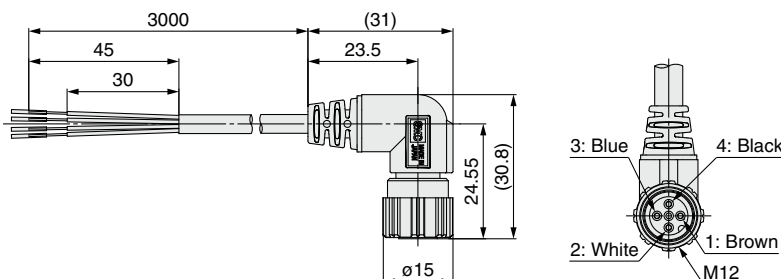

## Cable Specifications

Conductor	Nominal cross section	AWG23
	Outside diameter	0.72 mm
Insulator	Material	Cross-linked vinyl chloride
	Outside diameter	1.14 mm
	Number of cores	4
Sheath	Material	Oil resistant vinyl chloride
	Finished outside diameter	φ4

Pin no.	Lead wire color	Description
1	Brown	DC (+)
2	White	N.C.*1
3	Blue	DC (-)
4	Black	OUT1

\*1 The unconnected terminals are only used by SMC, so please do not connect them.

## Adapter with restrictor

### ZS-31-X□□□

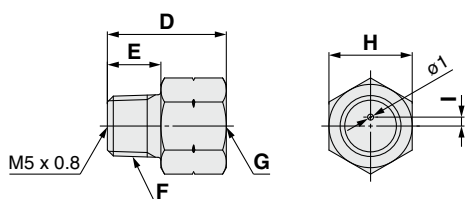

Part no.	D	E	F	G	H	I
ZS-31-X188	20	9	R1/8	Rc1/8	14	1.5
ZS-31-X175	29	13	R1/4	Rc1/4	17	1.6

\* If it is expected that the pressure, such as water hammer or surge pressure, will fluctuate rapidly, refer to the Precautions in the Operation Manual on the SMC website (<http://www.smcworld.com>).

# 3-Screen Display Sensor Monitor

# PSE300AC Series



RoHS



## How to Order

PSE3 **0** 0AC - **AB** - **M** - **□**

### Input specification

0	Voltage input
1	Current input

### Output specification

AB	2 output type (NPN or PNP switching type)
----	---

### Option (Power supply/Output lead wire)

Nil	Straight lead wire
L	Right angle lead wire
N	None

### Options/Part Nos.

Description	Part no.	Note
Power supply/output lead wire	ZS-31-B	Straight (5 m) 1 pc.
	ZS-31-C	Right angle (5 m) 1 pc.
Assembly-type connector	PCA-1557743	1 pc.

### Unit specification

Nil	With unit selection function*1
M	SI unit only*2
P	With unit selection function (Initial value psi)*1

\*1 Under the New Measurement Act, switches with a unit selection function are no longer allowed for use in Japan.

\*2 Fixed unit: Pa, kPa, MPa

## Specifications

For pressure switch precautions and specific product precautions, refer to the "Operation Manual" on the SMC website. Click [here](#) for details.

### M12 Connector Type

Series	PSE300AC									
Applicable SMC pressure sensor	PSE550	PSE531/PSE541 PSE561	PSE533/PSE543 PSE563/PSE573	PSE532	PSE564 PSE574	PSE530/PSE540 PSE560/PSE570	PSE575	PSE576	PSE577	
Rated pressure range	0 to 2 kPa	0 to -101 kPa	-100 to 100 kPa	0 to 100 kPa	0 to 500 kPa	0 to 1 MPa	0 to 2 MPa	0 to 5 MPa	0 to 10 MPa	
Display/Set pressure range	-0.2 to 2.1 kPa	10 to -105 kPa	-105 to 105 kPa	-10 to 105 kPa	-50 to 525 kPa	-0.105 to 1.05 MPa	-0.105 to 2.1 MPa	-0.1 to 5.25 MPa	-0.1 to 10.5 MPa	
Display/Smallest settable increment	0.001 kPa	0.1 kPa	0.1 kPa	0.1 kPa	0.1 kPa	1 kPa	0.001 MPa	0.001 MPa	0.01 MPa	
Electrical	Power supply voltage	12 to 24 VDC (±10%) with 10% voltage ripple or less								
	Current consumption	25 mA or less								
Accuracy	Protection	Reverse connection protection								
	Display accuracy	±0.5% F.S. ±Min. display unit (Ambient temperature of 25°C)								
	Repeatability	±0.1% F.S. ±Min. display unit (Ambient temperature of 25°C)								
	Temperature characteristics	±0.5% F.S. (Ambient temperature of 0 to 50°C, 25°C reference)								
Switch output	Output type	Select from NPN or PNP open collector output.								
	Output mode	Select from hysteresis mode, window comparator mode, error output or switch output OFF.								
	Switch operation	Select from normal output or reverse output.								
	Max. load current	20 mA								
	Max. applied voltage (NPN only)	30 VDC								
	Internal voltage drop (Residual voltage)	1 V or less (with load current of 20 mA)								
	Delay time *1	1 ms or less (with anti-chattering function: 20, 100, 500, 1000, 2000, 5000 ms)								
	Hysteresis	Variable from 0*2								
Sensor input	Protection	Over current protection								
	Input type	Voltage input: 1 to 5 VDC (Input impedance: 1 MΩ), Current input: 4 to 20 mA DC (Input impedance: 51 Ω)								
	Number of inputs	1 input								
	Connection method	M12-4 pin connector								
Display	Protection	Over voltage protection (up to a voltage of 26.4 VDC)								
	Unit *3	MPa, kPa, Pa, kgf/cm <sup>2</sup> , bar, mbar, psi, inHg, mmHg, mmH <sub>2</sub> O								
	Display type	LCD								
	Number of screens	3-screen display (Main screen, Sub screen x 2)								
	Display color	1) Main screen: Red/Green, 2) Sub screen: Orange								
	Number of display digits	1) Main screen: 4-digit (7-segment), 2) Sub screen: 4-digit (Upper 1-digit 11-segment, 7-segment for other)								
Digital filter *4	Indicator light	Lights up when switch output is turned ON. OUT1/OUT2: Orange								
Environment	Enclosure	IP65								
	Withstand voltage	1000 VAC for 1 minute between terminals and housing								
	Insulation resistance	50 MΩ or more (500 VDC measured via megohmmeter) between terminals and housing								
	Operating temperature range	Operating: 0 to 50°C, Stored: -10 to 60°C (No freezing or condensation)								
	Operating humidity range	Operating/Stored: 35 to 85% RH (No condensation)								
Standards	CE, RoHS									
Weight	55.4 g (without power supply or output lead wires)									

\*1 Value without digital filter (at 0 ms)

\*2 If the applied pressure fluctuates around the set value, the hysteresis must be set to a value more than the amount of fluctuation, or chattering will occur.

\*3 This setting is only available for models with the unit selection function. Only MPa, kPa, or Pa is available for models without this function.

\*4 The response time indicates when the set value is 90% in relation to the step input.

**Internal Circuits and Wiring Examples**

Setting of NPN open collector 2 outputs: Pressure sensor 3-wire type

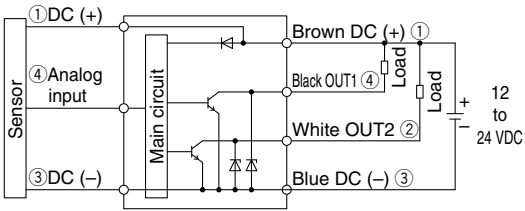

Setting of PNP open collector 2 outputs: Pressure sensor 3-wire type

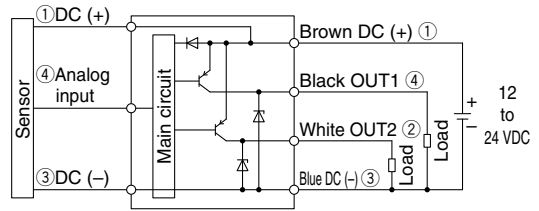

Setting of NPN open collector 2 outputs: Pressure sensor 2-wire type

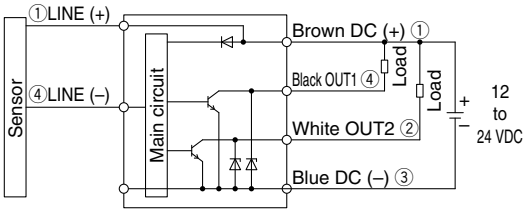

Setting of PNP open collector 2 outputs: Pressure sensor 2-wire type

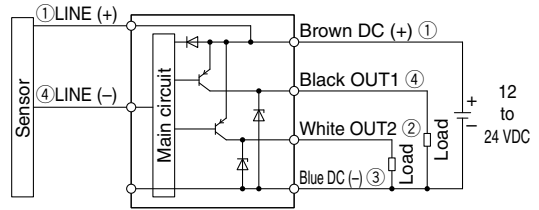

\* The output type can be changed in the function selection mode.  
 \* Numbers in the figures show the connector pin layout.

**Dimensions**

Power supply/Output connector pin no.

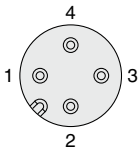

Pin no.	Description
1	DC (+)
2	OUT2
3	DC (-)
4	OUT1

Sensor connector pin no.

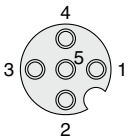

Pin no.	Description
1	DC (+)
2	N.C.
3	DC (-)
4	Sensor input (1 to 5 V, 4 to 20 mA)
5	N.C.

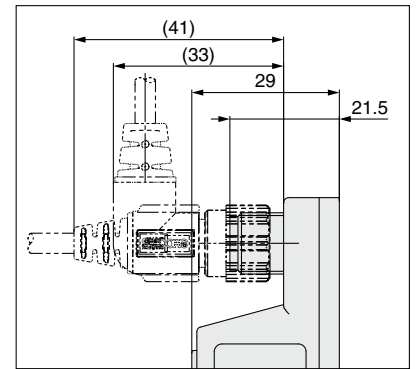
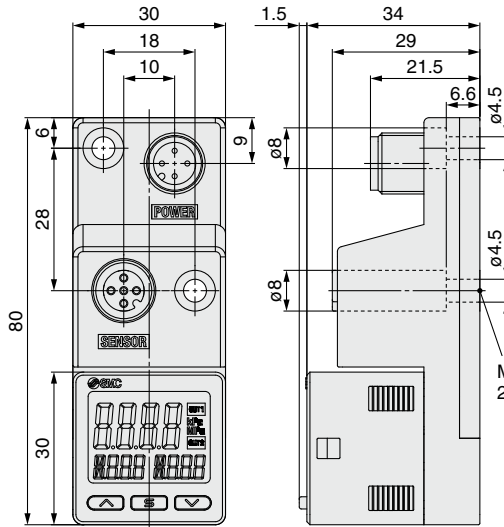

For power supply/output lead wire

Power supply/Output lead wire  
**ZS-31-B**

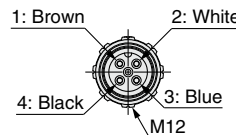
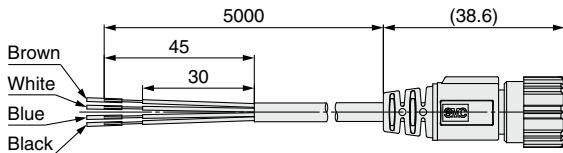

**ZS-31-C**

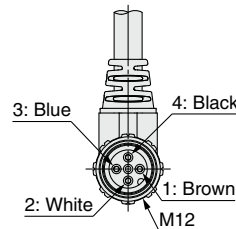
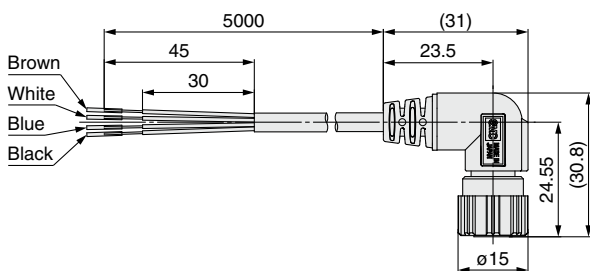

**Cable Specifications**

Conductor	Nominal cross section	AWG23
	Outside diameter	0.72 mm
Insulator	Material	Cross-linked vinyl chloride
	Outside diameter	1.14 mm
	Number of cores	4
Sheath	Material	Oil resistant vinyl chloride
	Finished outside diameter	ø4

Pin no.	Lead wire color	Description
1	Brown	DC (+)
2	White	OUT2
3	Blue	DC (-)
4	Black	OUT1

## Function Details

### A Auto-preset function (F4)

The auto-preset function, when selected in the initial setting, calculates and stores the set value from the measured pressure. For example, if this function is used for suction verification, the optimum set value is determined automatically by repeating vacuum and break with the target workpiece several times.

#### Suction Verification

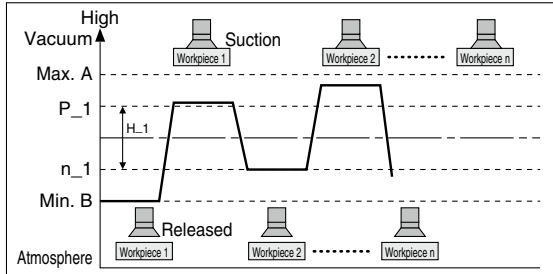

#### Formula for Obtaining the Set Value

P <sub>1</sub> or P <sub>2</sub>	H <sub>1</sub> or H <sub>2</sub>
$P_1 (P_2) = A - (A-B)/4$	$H_1 (H_2) =  (A-B)/2 $
$n_1 (n_2) = B + (A-B)/4$	

### B Display value fine adjustment function (F6)

Fine adjustment of the indicated value of the pressure sensor can be made within the range of ±5% of the read value. (This eliminates wide variations of the indicated value.)

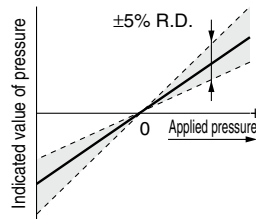

— Indicated value at the time of shipment  
 [Shaded Area] Adjustable range of display value fine adjustment function

Note) When the display value fine adjustment function is used, the set pressure value may change ±1 digit.

### C Peak/Bottom value indication function

This function constantly detects and updates the maximum (minimum) pressure when the power is supplied, and allows the holding of the maximum (minimum) pressure value.

The hold value can be maintained even if the power supply is cut. When the buttons are simultaneously pressed for 1 second or longer while "holding," the hold value will be reset.

### D Keylock function

The keylock function prevents operation errors such as the accidental changing of setting values.

### E Zero-clear function

This function clears and resets the zero value on the display of measured pressure.

The indicated value can be adjusted within ±7% F.S. of the pressure at the time of factory shipment. (±3.5% F.S. for compound pressure)

### F Error indication function

This function displays error location and content when a problem or error has occurred.

Error name	Error code	Description	Action
Over current error		Load current of 20 mA or more is applied to the switch output	Turn the power off and remove the cause of the over current. Then supply the power again.
Residual pressure error		During zero-clear operation, pressure over ±7% F.S. (±3.5% F.S. for compound pressure) is present. Note that the mode is returned to measurement mode automatically 1 second later. The zero-clear range varies by ±1% F.S. due to the variation between individual products.	Use the zero-clear function again after restoring the applied pressure to atmospheric pressure.
Applied pressure error		Supply pressure exceeds the maximum set pressure	Reset the applied pressure to a level within the set pressure range.
		Supply pressure is below the minimum set pressure	
System error	  	Internal data error	Turn off the power supply and then turn it on again. If the problem cannot be solved, please contact SMC.

If the error cannot be reset after the above measures are taken, or errors other than those above are displayed, please contact SMC.

## Function Details

### G Anti-chattering function (Simple setting mode or F1)

A large bore cylinder or ejector consumes a large volume of air during operation and may experience a temporary drop in the supply pressure. This function prevents the detection of such temporary drops in the supply pressure as errors by changing the delay time setting.

Available delay time settings
1 ms or less, 20 ms, 100 ms, 500 ms, 1000 ms, 2000 ms, 5000 ms

<Principle>

This function averages pressure values measured during the response time set by the user and then compares the average pressure value with the pressure set point value to output the result on the switch.

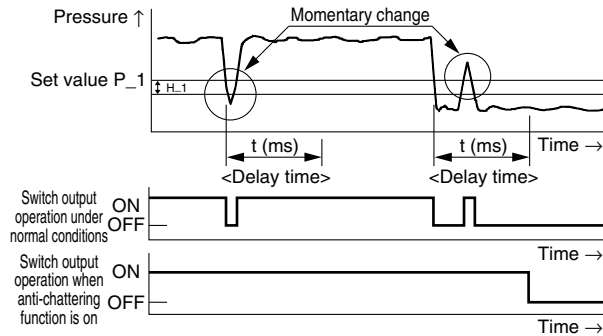

### H Unit selection function (F0)

Display units can be switched with this function.

Smallest settable increment	Display unit	Rated pressure range	MPa	kPa	Pa	kgf/cm <sup>2</sup>	bar	mbar	psi	inHg	mmHg	mmH <sub>2</sub> O
			MPa*1	kPa	Pa	kgf/cm <sup>2</sup>	bar	mbar	psi	inHg	mmHg	mmH <sub>2</sub> O
Applicable SMC pressure sensor	PSE550	0 to 2 kPa	/	0.001	1	/	/	0.01	0.001	/	/	0.1
	PSE531 PSE541 PSE561	0 to -101 kPa	0.001	0.1	/	0.001	0.001	/	0.01	0.1	1	/
	PSE533 PSE543 PSE563 PSE573	-100 to 100 kPa	0.001	0.1	/	0.001	0.001	/	0.02	0.1	1	/
	PSE532	0 to 100 kPa	0.001	0.1	/	0.001	0.001	/	0.01	/	/	/
	PSE564 PSE574	0 to 500 kPa	0.001	1	/	0.01	0.01	/	0.1	/	/	/
	PSE530 PSE540 PSE560 PSE570	0 to 1 MPa	0.001	1	/	0.01	0.01	/	0.1	/	/	/
	PSE575	0 to 2 MPa	0.001	1	/	0.01	0.01	/	0.2	/	/	/
	PSE576	0 to 5 MPa	0.01	/	/	0.1	0.1	/	1	/	/	/
	PSE577	0 to 10 MPa	0.01	/	/	0.1	0.1	/	1	/	/	/

\*1 The PSE5□1 (vacuum pressure), PSE5□2 (low pressure), and PSE5□3 (compound pressure) will have different setting and display resolution when the unit is set to MPa.

### I Power-saving mode (F80)

Power-saving mode can be selected.

It shifts to power-saving mode automatically when there is no button operation for 30 seconds.

The product is set to normal mode (Power-saving mode is OFF) at the time factory shipment.

(When in power-saving mode, [ECO] will flash in the sub screen and the operation light will be ON (only when the switch is ON).)

### J Setting of secret code (F81)

Users can select whether a secret code must be entered to release the key lock.

At the time of factory shipment, it is set so that a secret code is not required.

# Options / Connection Examples

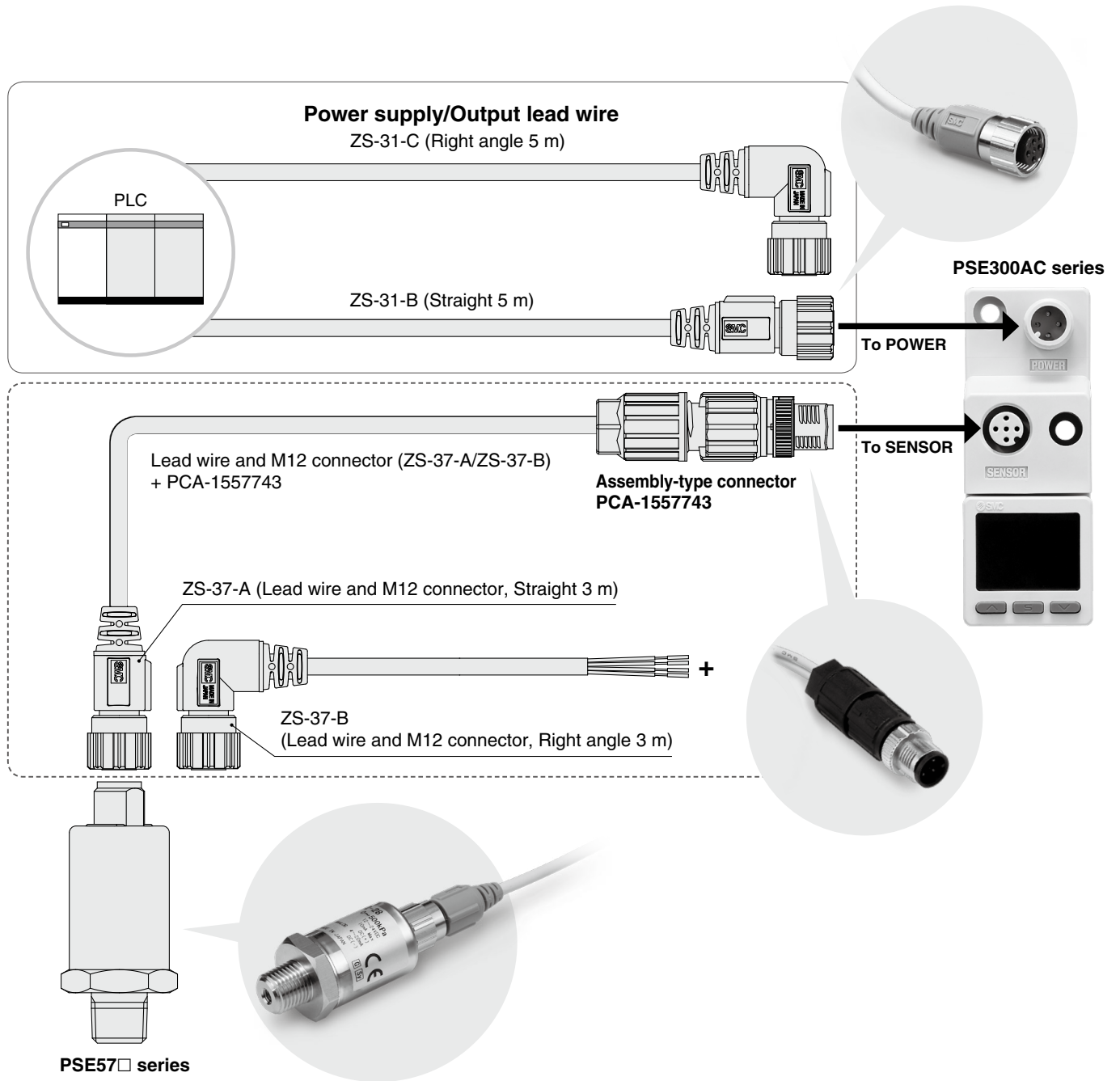

## Safety Instructions

These safety instructions are intended to prevent hazardous situations and/or equipment damage. These instructions indicate the level of potential hazard with the labels of “**Caution**,” “**Warning**” or “**Danger**.” They are all important notes for safety and must be followed in addition to International Standards (ISO/IEC)\*1), and other safety regulations.

 **Caution:** **Caution** indicates a hazard with a low level of risk which, if not avoided, could result in minor or moderate injury.

 **Warning:** **Warning** indicates a hazard with a medium level of risk which, if not avoided, could result in death or serious injury.

 **Danger :** **Danger** indicates a hazard with a high level of risk which, if not avoided, will result in death or serious injury.

\*1) ISO 4414: Pneumatic fluid power – General rules relating to systems.  
ISO 4413: Hydraulic fluid power – General rules relating to systems.  
IEC 60204-1: Safety of machinery – Electrical equipment of machines.  
(Part 1: General requirements)  
ISO 10218-1: Manipulating industrial robots – Safety.  
etc.

### Warning

#### 1. The compatibility of the product is the responsibility of the person who designs the equipment or decides its specifications.

Since the product specified here is used under various operating conditions, its compatibility with specific equipment must be decided by the person who designs the equipment or decides its specifications based on necessary analysis and test results. The expected performance and safety assurance of the equipment will be the responsibility of the person who has determined its compatibility with the product. This person should also continuously review all specifications of the product referring to its latest catalog information, with a view to giving due consideration to any possibility of equipment failure when configuring the equipment.

#### 2. Only personnel with appropriate training should operate machinery and equipment.

The product specified here may become unsafe if handled incorrectly. The assembly, operation and maintenance of machines or equipment including our products must be performed by an operator who is appropriately trained and experienced.

#### 3. Do not service or attempt to remove product and machinery/equipment until safety is confirmed.

1. The inspection and maintenance of machinery/equipment should only be performed after measures to prevent falling or runaway of the driven objects have been confirmed.
2. When the product is to be removed, confirm that the safety measures as mentioned above are implemented and the power from any appropriate source is cut, and read and understand the specific product precautions of all relevant products carefully.
3. Before machinery/equipment is restarted, take measures to prevent unexpected operation and malfunction.

#### 4. Contact SMC beforehand and take special consideration of safety measures if the product is to be used in any of the following conditions.

1. Conditions and environments outside of the given specifications, or use outdoors or in a place exposed to direct sunlight.
2. Installation on equipment in conjunction with atomic energy, railways, air navigation, space, shipping, vehicles, military, medical treatment, combustion and recreation, or equipment in contact with food and beverages, emergency stop circuits, clutch and brake circuits in press applications, safety equipment or other applications unsuitable for the standard specifications described in the product catalog.
3. An application which could have negative effects on people, property, or animals requiring special safety analysis.
4. Use in an interlock circuit, which requires the provision of double interlock for possible failure by using a mechanical protective function, and periodical checks to confirm proper operation.

### Caution

#### 1. The product is provided for use in manufacturing industries.

The product herein described is basically provided for peaceful use in manufacturing industries.  
If considering using the product in other industries, consult SMC beforehand and exchange specifications or a contract if necessary.  
If anything is unclear, contact your nearest sales branch.

### Limited warranty and Disclaimer/ Compliance Requirements

The product used is subject to the following “Limited warranty and Disclaimer” and “Compliance Requirements”.

Read and accept them before using the product.

#### Limited warranty and Disclaimer

1. The warranty period of the product is 1 year in service or 1.5 years after the product is delivered, whichever is first.\*2)  
Also, the product may have specified durability, running distance or replacement parts. Please consult your nearest sales branch.
2. For any failure or damage reported within the warranty period which is clearly our responsibility, a replacement product or necessary parts will be provided.  
This limited warranty applies only to our product independently, and not to any other damage incurred due to the failure of the product.
3. Prior to using SMC products, please read and understand the warranty terms and disclaimers noted in the specified catalog for the particular products.

##### \*2) Vacuum pads are excluded from this 1 year warranty.

A vacuum pad is a consumable part, so it is warranted for a year after it is delivered.  
Also, even within the warranty period, the wear of a product due to the use of the vacuum pad or failure due to the deterioration of rubber material are not covered by the limited warranty.

#### Compliance Requirements

1. The use of SMC products with production equipment for the manufacture of weapons of mass destruction (WMD) or any other weapon is strictly prohibited.
2. The exports of SMC products or technology from one country to another are governed by the relevant security laws and regulations of the countries involved in the transaction. Prior to the shipment of a SMC product to another country, assure that all local rules governing that export are known and followed.

### Caution

#### SMC products are not intended for use as instruments for legal metrology.

Measurement instruments that SMC manufactures or sells have not been qualified by type approval tests relevant to the metrology (measurement) laws of each country. Therefore, SMC products cannot be used for business or certification ordained by the metrology (measurement) laws of each country.

## Safety Instructions

Be sure to read the “Handling Precautions for SMC Products” (M-E03-3) and “Operation Manual” before use.