

Datasheet - RSS 36-I2-D-ST

Safety sensors / RSS 36



(Minor differences between the printed image and the original product may exist!)

- Thermoplastic enclosure
- RFID-technology for needs-based protection against tampering
- Misaligned actuation possible
- 27 mm x 108.2 mm x 35 mm
- High repeat accuracy of the switching points
- 2 short-circuit proof PNP safety outputs
- Integral cross-short, wire-breakage and external voltage monitoring of the safety cables up to the control cabinet
- Repeated individual coding with RFID technology
- Coding level "High" according to ISO 14119
- 1 x connector socket M12, 8-pole
- Actuation from side
- Max. 31 sensors can be wired in series.

Ordering details

Product type description	RSS 36-I2-D-ST
Article number	101216956
EAN Code	4030661413389
eCl@ss	27-27-24-01

Approval

Approval

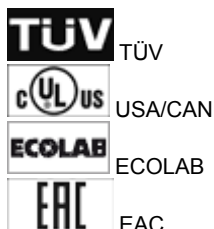

Classification

Standards	EN ISO 13849-1, IEC 61508, IEC 60947-5-3, EN 62061
PL	bis e
Control category	bis 4
PFH	2.7 x 10 ⁻¹⁰ /h
SIL	3
Mission time	20 Years
Classification	PDF-M

Global Properties

Permanent light	RSS 36
Standards	IEC 60947-5-3
Compliance with the Directives (Y/N) 	Yes
Suitable for safety functions (Y/N)	Yes
Function	Sensor for series wiring
Series-wiring	up to 31 components
Length of the sensor chain	max. 30 m
Mounting	For the assembly of the sensors as well as for flat mounted actuators 25 mm screw length is usually sufficient. The 30 mm long screws are recommended when the actuator is mounted upright and/or when the sealing disks are used.
Active principle	RFID
Coding levels according to ISO 14119	High
Coding	Individual coding, multiple teaching
Materials	
- Material of the active surface	Plastic, glass-fibre reinforced thermoplastic
- Material of the housings	Plastic, glass-fibre reinforced thermoplastic, self-extinguishing
Housing construction form	Block
Weight	80
Input for enabling pushbutton, suitable for automatic start (Y/N)	No
Input for reset pushbutton, with edge monitoring (Y/N)	No
Diagnostic output (Y/N)	Yes
Reaction time	≤ 100
Duration of risk	≤ 200
Time to readiness	≤ 5 s
Cascadable (Y/N)	Yes
Recommended actuator	RST 36-1, RST 36-1-R

Mechanical data

Design of electrical connection	Connector M12, 8-pole
mechanical installation conditions	not flush
Actuating planes	Actuation from side
Active area	lateral
Switch distance	12
Ensured switch distance ON	10
Ensured switch distance OFF	20
hysteresis	max. 2 mm
Repeat accuracy R R	< 0,5 mm
notice	Axial offset: The long side allows for a maximum height misalignment (x) of sensor and actuator of 8 mm (e.g. mounting tolerance or due to guard door sagging). The axial misalignment (y) is max. ± 18 mm. see drawing: Operating principle
restistance to shock	minimum distance 100 mm in case of approach from side 30 g / 11 ms
Resistance to vibration	10 ... 55 HZ, Amplitude 1 mm
Latching (Y/N)	No

Ambient conditions

Ambient temperature	
- Min. environmental temperature	-25

- Max. environmental temperature	+70
Storage and transport temperature	
- Min. Storage and transport temperature	-25
- Max. Storage and transport temperature	+85
Temperature resistance cable	
- min. Temperature resistance	-30 in position of rest, -10 in Movement
- max. Temperature resistance	+105
Protection class	IP65, IP67, IP69 to IEC/EN 60529
Protection rating	III
Air clearances and creepage distances To IEC/EN 60664-1	
- Rated impulse withstand voltage U_{imp}	0,8 kV
- Overvoltage category	III
- Degree of pollution	3

Electromagnetic compatibility (EMC)

EMC rating	to IEC 60947-3
Interfering radiation	to IEC 61000-6-4

Electrical data

Cross circuit/short circuit recognition possible (Y/N)	Yes
Voltage type	DC
Switch frequency	1
Rated insulation voltage U_i	32 VDC
Rated operating voltage U_e (stabilised PELV)	
- Min. Rated operating voltage	20.4 VDC
- Max. Rated operating voltage	26.4 VDC
Operating current I_e	0,6 A
No-load current I_0	0,1 A
Required rated short-circuit current	100 A
notice	The cable section of the interconnecting cable must be observed! Cable length and cable section alter the voltage drop depending on the output current

Electrical data - Safety inputs

Safety inputs	X1 and X2
Rated operating voltage U_e	24 VDC -15% / +10%

Electrical data - Safety outputs

Safety outputs	Y1 and Y2
Fuse rating	short-circuit proof
Design of control output	p-type
Number of secure semi-conductor outputs	2
Max. output current at secured output	0,25 A
Rated operating voltage	min. ($U_e - 1$ V)
Residual current I_r	$\leq 0,5$ mA
Operating current I_e	max. 0,25 A
- Ambient temperature: -25 °C ... +70 °C	$\leq 0,1$ A
Minimum operating current I_m	0,5 mA
- Ambient temperature: -25 °C ... +65 °C	$\leq 0,25$ A
Utilisation category	DC-12: 24 V / 0,25 A DC-13: 24 V / 0,25 A

Voltage drop U_d < 1 V

Electrical data - Diagnostic output

Serial diagnostics (Y/N)	No
Fuse rating	short-circuit proof
Design of control output	p-type
Number of semi-conductor outputs with signaling function	1
Rated operating voltage	$U_e < 2 \text{ V}$
Operating current	0,05 A
Utilisation category	DC-12: 24 V / 0,05 A DC-13: 24 V / 0,05 A

LED switching conditions display

LED switching conditions display (Y/N)	Yes
Number of LED's	3
green LED	Supply voltage
red LED	Error
yellow LED	switching condition

ATEX

Explosion protection categories for gases	None
Explosion protected category for dusts	None

Dimensions

Dimensions of the sensor	
- Width of sensor	106.3
- Height of sensor	25
- Length of sensor	22

Pin assignment

1 - A1 U_e	Brown
2 - X1 Safety input 1	White
3 - A2 GND	Blue
4 - Y1 Safety output 1	Black
5 - OUT Diagnostic output OUT	Grey
6 - X2 Safety input 2	violet
7 - Y2 Safety output 2	red
8 - IN without function	Pink

notice

Requirements for the safety monitoring module

2-channel safety input, suitable for p-type sensors with NO function. The safety monitoring module must tolerate internal functional tests of the sensors with cyclic switch-off of the sensor outputs for max. 0,25 ms. The safety monitoring module does not need to have a cross-wire short monitoring function.

notice

Coding procedure: teaching of the individual coding of a RST actuator through a simple routine during start-up (as -I1). A protected coding process enables teaching a new actuator in case of maintenance.

Included in delivery

Actuators must be ordered separately.

Ordering code

RSS 36 (1)-(2)-(3)-ST

(1)	
<i>without</i>	Included in standard version Coding
I1	Individual coding
I2	Individual coding, for multiple applications
(2)	
D	with Diagnostic output
SD	with serial diagnostic function
(3)	
<i>without</i>	without latching
R	with latching, Latching force approx. 18 N

Documents

Operating instructions and Declaration of conformity (it) 462 kB, 04.10.2017

Code: mrl_rss36-rst36-1_it

Operating instructions and Declaration of conformity (pl) 520 kB, 14.08.2018

Code: mrl_rss36-rst36-1_pl

Operating instructions and Declaration of conformity (fr) 503 kB, 23.05.2018

Code: mrl_rss36-rst36-1_fr

Operating instructions and Declaration of conformity (en) 497 kB, 17.09.2018

Code: mrl_rss36-rst36-1_en

Operating instructions and Declaration of conformity (nl) 498 kB, 14.08.2018

Code: mrl_rss36-rst36-1_nl

Operating instructions and Declaration of conformity (de) 453 kB, 18.04.2018

Code: mrl_rss36-rst36-1_de

Operating instructions and Declaration of conformity (es) 503 kB, 24.05.2018

Code: mrl_rss36-rst36-1_es

Operating instructions and Declaration of conformity (pt) 505 kB, 23.05.2018

Code: mrl_rss36-rst36-1_pt

Operating instructions and Declaration of conformity (jp) 577 kB, 22.08.2017

Code: mrl_rss36-rst36-1_jp

Brochure (de) 6 MB, 15.02.2018

Code: b_css_brosch09_de

Brochure (en) 6 MB, 15.02.2018

Code: b_css_brosch09_en

TÜV certification (de, en) 505 kB, 12.09.2018

Code: z_rssp01

EAC certification (ru) 747 kB, 05.10.2015

Code: q_6396p17_ru

ECOLAB certification (de) 606 kB, 03.07.2018

Code: q_rssp01

ECOLAB certification (en) 575 kB, 03.07.2018

Code: q_rssp02

notice - Switch distance (it) 163 kB, 26.09.2016

Code: mrl_rss36-beiblatt-schaltabstand_it

notice - Switch distance (en) 211 kB, 20.09.2016

Code: mrl_rss36-beiblatt-schaltabstand_en

notice - Switch distance (de) 220 kB, 26.09.2016

Code: mrl_rss36-beiblatt-schaltabstand_de

notice - Switch distance (nl) 157 kB, 23.09.2016

Code: mrl_rss36-beiblatt-schaltabstand_nl

notice - Switch distance (es) 158 kB, 26.09.2016

Code: mrl_rss36-beiblatt-schaltabstand_es

notice - Switch distance (pl) 167 kB, 12.12.2016

Code: mrl_rss36-beiblatt-schaltabstand_pl

notice - Switch distance (fr) 156 kB, 26.09.2016

Code: mrl_rss36-beiblatt-schaltabstand_fr

Images

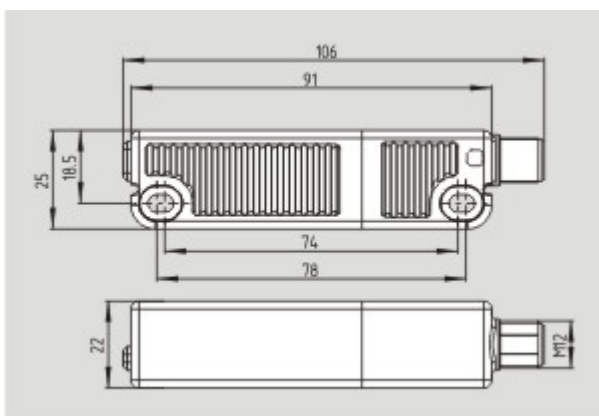

Dimensional drawing (basic component)

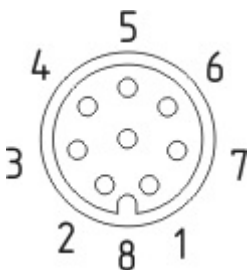

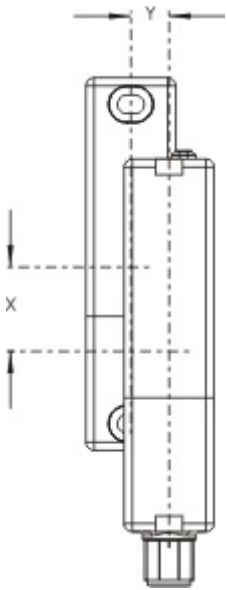

Product graph

System components

Actuator



101213821 - RST 36-1-R

- Actuation from side
 - with latching magnet
 - Simple flexible mounting and adjustment
-



101213820 - RST 36-1

- Actuation from side
 - Simple flexible mounting and adjustment
-

Accessories



101215048 - ACC RSS 36-SK

- to seal the mounting holes and as spacer (approx. 3 mm) to facilitate the cleaning below the mounting surface
 - also suitable as tampering protection for the screw fixings
-

Connector



101209960 - A-K8P-M12-S-G-10M-BK-1-X-A-2

- 10 m



101209964 - A-K8P-M12-S-G-5M-BK-1-X-A-2

- 5 m



101209963 - A-K8P-M12-S-G-2,5M-BK-1-X-A-2

- 2.5 m



101210561 - A-K8P-M12-S-W-5M-BK-1-X-A-4-69-VA

- 5 m
- Pre-wired cable
- angled
- 8-pole



101210560 - A-K8P-M12-S-G-5M-BK-1-X-A-4-69-VA

- 5 m
- Pre-wired cable
- 8-pole

Mounting accessories



101217747 - NRS-M4X30-FHS-4PCS

- Set of 4 Tamperproof screws M4 x 30
- Stainless steel (V4A)



101217746 - NRS-M4X25-FHS-4PCS

- Set of 4 Tamperproof screws M4 x 25 and Washer
- Stainless steel (V4A)