

Large bore type A02H (hollow shaft)

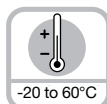

Temperature



Shock/vibration resistant



Short-circuit protection



Reverse polarity protection



High rotational speed

Rugged

- Balanced, stainless-steel clamping rings, special bearing-shaft connection increases stability and vibration resistance.
- Optional plastic isolating inserts protect against damage from shaft currents.
- New type of mechanical construction, ideal for handling tough mechanical stresses and strains.

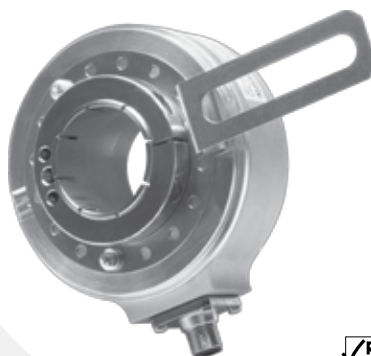

Versatile

- Very compact. Optional isolating inserts protect against damage from shaft currents, e.g. with AC vector motors.
- Only 49 mm clearance needed.
- Hollow shaft diameter up to Ø 42 mm.
- RS422, push-pull or SIN/COS outputs.
- Extended speed range up to 6,000 RPM.
- High-quality construction, balanced, stainless steel - ensures quiet vibration-free running.

Economical

- Alternative to traditional heavy duty encoders that are often over-engineered and expensive.

Mechanical characteristics:

Speed:	max. 6,000 RPM at 158°F (70°C) ¹⁾ max. 3,500 RPM at 176°F (80°C) ¹⁾
Rotor moment of inertia:	< 12 oz-in ² (< 220 x 10 ⁻⁶ kgm ²) ²⁾
Starting torque with sealing:	< 28.3 oz-in (< 0.2 Nm)
Weight:	approx. 1.8 lbs (0.8 kg)
Protection acc. to EN 60 529:	IP65
EX approval for hazardous areas:	optional zone 2 and 22
Working temperature:	-4 to +176°C (-20 to +80°C) ³⁾
Shaft:	stainless steel H7
Shock resistance acc. to DIN-IEC 68-2-27	200 g (2,000 m/s ²), 6 ms
Vibration resistance acc. to DIN-IEC 68-2-6:	10 g (100 m/s ²), 10-2,000 Hz

¹⁾ During the run-in-phase of approx. 2 hours, reduce the limits for working temperature max or speed max by 1/3

²⁾ Dependent on the shaft diameter

³⁾ Non-condensing

Electrical characteristics sine wave output:

Output circuit:	Sine U = 1 V _{ss}	Sine U = 1 V _{ss}
Supply voltage:	5 V (±5 %)	10-30 VDC
Current consumption (no load) with inverted signal:	typ. 65 mA / max. 110 mA	typ. 65 mA / max. 110 mA
-3 dB frequency:	≥ 180 kHz	≥ 180 kHz
Signal level channels A/B:	1 V _{ss} (±20%)	1 V _{ss} (±20%)
Signal level channel 0:	0.1-1.2 V	0.1-1.2 V
Short-circuit proof outputs ¹⁾ :	yes	yes
Reverse connection protection at +V:	no	yes
UL certified	File 224618	
Conforms to CE requirements acc. to EN 61000-6-1, EN 61000-6-4 and EN 61000-6-3		
RoHS compliant acc. to EU guideline 2002/95/EG		

¹⁾ If supply voltage correctly applied

Large bore type A02H (hollow shaft)

Electrical characteristics RS422 or push-pull output:

Output circuit:	RS 422 (TTL compatible)	Push-pull	Push-pull (7272) ³⁾
Supply voltage:	5 V (±5 %) or 10-30 VDC	10-30 VDC	5-30 VDC
Power consumption (no load) without inverted signal:	-	typ. 55 mA / max. 125 mA	-
Power consumption (no load) with inverted signal:	typ. 40 mA / max. 90 mA	typ. 80 mA / max. 150 mA	typ. 50 mA / max. 100 mA
Permissible load/channel:	max. ±20 mA	max. ±30 mA	max. ±20 mA
Pulse frequency:	max. 300 kHz	max. 300 kHz	max. 300 kHz
Signal level high:	min. 2.5 V	min. +V -3 V	min. +V -2.0 V
Signal level low:	max. 0.5 V	max. 2.5 V	max. 0.5 V
Rise time t _r :	max. 200 ns	max. 1 μs	max. 1 μs
Fall time t _f :	max. 200 ns	max. 1 μs	max. 1 μs
Short-circuit proof outputs ¹⁾ :	yes ²⁾	yes	yes
Reverse connection protection at +V:	5 V: no, 10-30 V: yes	yes	no
UL certified:	File 224618		
Conforms to CE requirements acc. to EN 61000-6-1, EN 61000-6-4 and EN 61000-6-3			

¹⁾ If supply voltage correctly applied

²⁾ Only one channel allowed to be shorted-out:

(If +V = 5 V, short-circuit to channel, 0 V, or +V is permitted) (If +V = 5-30 V, short-circuit to channel or 0 V is permitted)

³⁾ Max. recommended cable length 30 m

Standard wiring / pin configuration:

Output:	Case Ground	Common (0 V)	+V	A	\bar{A}	B	\bar{B}	Z	\bar{Z}	-	-
M23 <i>multifast</i> ®	Coupling Nut	10	12	5	6	8	1	3	4	-	-
MS 7-pin	G	F	D	A	-	B	-	C	-	-	-
MS 10-pin	J	F	D	A	G	B	H	C	I	-	-
M12 <i>eurofast</i> ®	Coupling Nut	1	2	3	4	5	6	7	8	-	-
Cable:	Shield/Drain	WH	BN	GN	YE	GY	PK	BU	RD	BK	VT

Special connector pin configuration:

Output Code	Output:	Case Ground	Common (0 V)	+V	A	\bar{A}	B	\bar{B}	Z	\bar{Z}	-	-
7	M23 <i>eurofast</i>	Coupling Nut	7	2	1	3	4	5	6	8	-	-
2	MS 7-pin	G	F	D	A	C	B	E	-	-	-	-
6	MS 10-pin	G	F	D	A	H	B	I	C	J	-	-

Wiring diagrams:

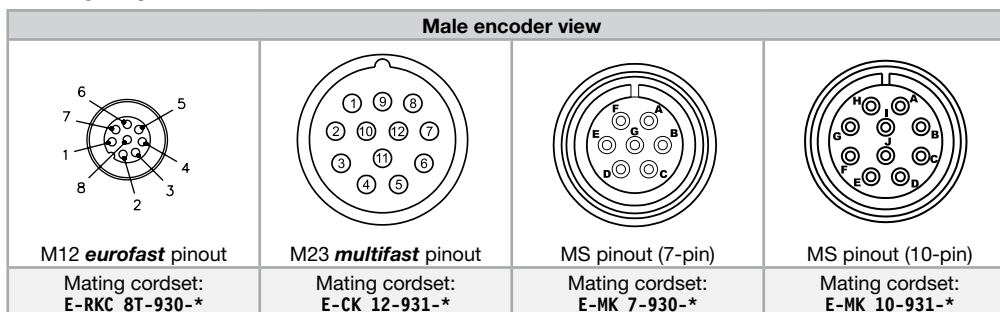

* Length in meters.

Large bore type A02H (hollow shaft)

Part number key: A02H hollow shaft version

T8.A02H.XXXX.XXXX.PXXXX

Options for special output only.

Type		
Flange		
1 = face mount	5 = tether arm (long)	
2 = short anti-rotation spring	6 = 4 1/2" C-face tether	
3 = long anti-rotation spring		
Hollow shaft		
1 = Ø 42 mm	A = Ø 30 mm ¹⁾	G = Ø 1-1/8" ¹⁾
2 = Ø 38 mm	B = Ø 40 mm	H = Ø 35 mm
3 = Ø 28 mm	C = Ø 20 mm ¹⁾	M = Ø 19 mm
4 = Ø 25.4 mm (1") ¹⁾	D = Ø 1/2"	N = Ø 1-1/4" ¹⁾
5 = Ø 25 mm ¹⁾	E = Ø 5/8" ¹⁾	P = Ø 32 mm ²⁾
6 = Ø 24 mm	F = Ø 3/4" ¹⁾	
Output circuit and voltage supply		
1 = RS422 (with inverted signal), 5 V supply voltage		
3 = push-pull (with inverted signal), 10-30 V supply voltage		
4 = RS422 (with inverted signal), 10-30 V supply voltage		
5 = push pull (with inverted signal), 5-30 V supply voltage		
8 = SIN/COS 1 Vpp (with inverted signal), 5 V supply voltage ³⁾		
9 = SIN/COS 1 Vpp (with inverted signal), 10-30 V supply voltage ³⁾		
A = line driver 7272, 5-30 V supply voltage		
B = 5-30 VDC / open collector (7273)		
D = 5-30 VDC / TTL (26C31)		
E = 5-30 VDC / TTL line driver (7272)		

Special connector pin configuration

0 = standard wiring
Other = see page C35

Special insert options

A = isolation insert not included
B = isolation insert included ⁴⁾

Special output signal formats

00 = standard output
Other = see page C42

Pulse rate

50*, 360*, 512*, 600*, 1000*, 1024, 1500, 2000, 2048, 2500, 4096, 5000
* not for SIN/COS version (SIN/COS version not available with pulses <1024)
(e.g. 360 pulses => 0360) Other pulse rates on request

Type of connection

1 = cable radial (1 m PVC-cable)
2 = radial 12-pin plug without mating connector
D = radial MS, 10-pin (MS 3102R18-1P)
E = radial connector M12 8-pin
K = radial MS, 7-pin (MS 3102R165-1P)

¹⁾ Boxes available with isolation inserts.
²⁾ This bored size only available as an isolation insert.
³⁾ P04XX is the only valid output code for SIN/COS outputs.
⁴⁾ Includes plastic hollow shaft inserts for electrical isolation.

Accessories:

- See page J1, Connectivity, for cables and connectors

Dimensions: A02H hollow shaft version

A02H flange

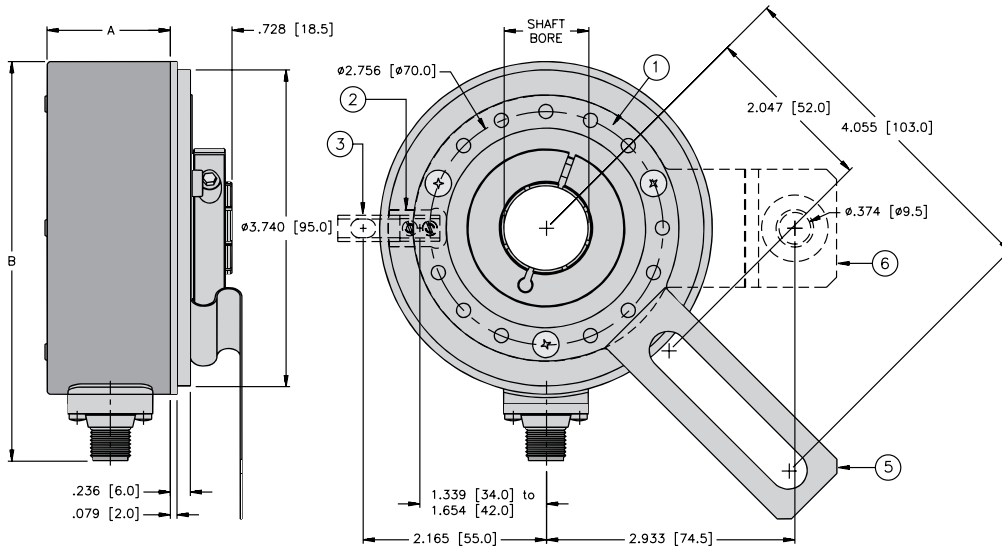

- 1 = face mount
- 2 = short anti-rotation spring
- 3 = long anti-rotation spring
- 5 = tether arm (long)
- 6 = 4 1/2" C-face tether

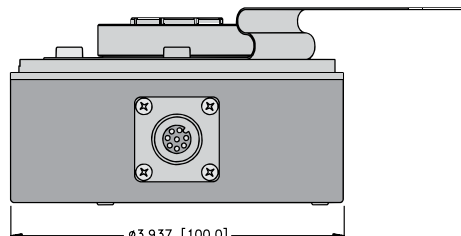

Dimensions for Radial Connector - in [mm]

DIM	Connection Style				
	Cable	M12	M23	MS (7-pin)	MS (10-pin)
A	1.181 [30.0]	1.181 [30.0]	1.181 [30.0]	1.457 [37.0]	1.457 [37.0]
B	-	4.705 [119.5]	4.961 [126.0]	5.079 [129.0]	5.394 [137.0]

Large bore type A02H (hollow shaft)

Mating shaft requirements:

Type of flange	Axial end play	Radial runout	Angular offset
Type 2 (anti-rotational spring short)	max. ± 1 mm	max. ± 0.3 mm	max. $\pm 2^\circ$
Type 3 (anti-rotational spring long)	max. ± 1 mm	max. ± 0.3 mm	max. $\pm 2^\circ$
Type 5 (tether arm long)	max. ± 0.5 mm	max. ± 0.3 mm	max. $\pm 2^\circ$
Type 6 (C-face tether)	max. ± 0.5 mm	max. ± 0.3 mm	max. $\pm 2^\circ$

Mounting:

Mounting using the spring element - short:

When mounting the encoder, ensure that dimension **L** is larger than the maximum axial play of the drive in the direction of the arrow.

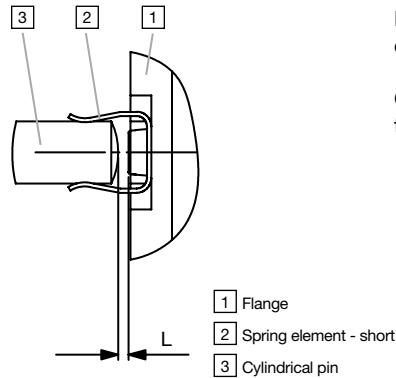

Mounting using the spring element - long:

Cylindrical pin fed through the bore of the spring.

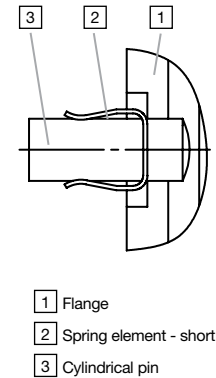

Large bore type A02H (hollow shaft) accessories

Isolation insert



The A02H encoder is used for AC vector motor and general industrial applications. For AC vector motor applications, the encoder should be electrically isolated from the motor chassis to minimize encoder bearing currents and ground noise. An isolation insert for the hollow shaft is provided with the encoder by specifying B0 in the “special insert option” decode. **When ordering isolation inserts separately, choose option A0 with a bore diameter of 38 mm.**

Part Number:	Inner Dimensions
8.0010.4013.0000	12.7 mm (1/2")
8.0010.4070.0000	15.875 mm (5/8")
8.0010.4019.0000	16 mm
8.0010.4080.0000	18 mm
8.0010.4090.0000	19.05 mm (3/4")
8.0010.4011.0000	20 mm
8.0010.4012.0000	25 mm
8.0010.4050.0000	25.4 mm (1")
8.0010.4014.0000	28.58 mm (1-1/8")
8.0010.4016.0000	30 mm
8.0010.4060.0000	31.75 mm (1-1/4")
8.0010.4015.0000	32 mm

For general industrial applications, isolation is not required and the decode for “special insert options” can be left blank.

Isolation insert for hollow shaft Ø 42 mm:

External diameter 42 mm
Internal diameter 38 H7 in accordance with ISO 286-2
Order Number: **T8.0010.4017.0000**

Large bore type A02H (hollow shaft) accessories

Part Number:
ENCODER COVER KIT

Description:
 Cover kit for 4.5" C-face motors

Included: (3) 3/8 x 16 x 3/4 bolts, (3) washers

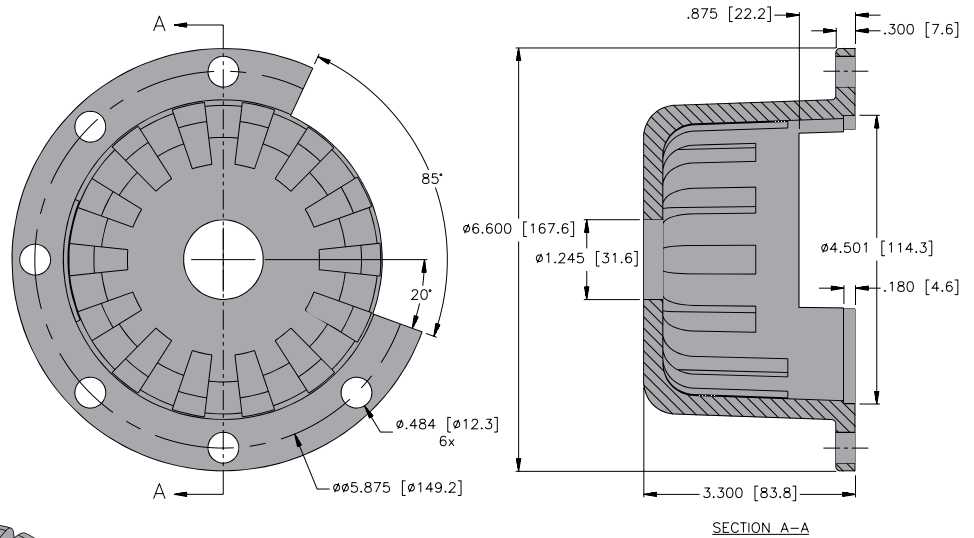

Part Number:
8.0010.4028.0000

Description:
 Mounting kit adapts the A02H hollow shaft encoder for mounting onto a tapered shaft. Tapered shafts are used for high-precision direct coupling to direct devices. An isolating insert is also included in the mounting kit; this reliably protects the encoder from shaft currents.

Included: Insert for cone blind hole, cone 1:10, 17 mm length, insulation insert, allen screw for tightening

