

Reliable

- **Increased ability to withstand vibration and installation errors.** Sturdy Safety-Lock™ Design bearing structure eliminates machine downtime and repairs.
- **Fewer components and connection points increase the operational reliability:** TURCK OptoASIC technology with highest integration density (Chip-on-Board).
- **Die cast housing and protection up to IP67:** Remains sealed even when subjected to harsh everyday use.
- **Wide temperature range.**
- **Easy diagnosis in case of fault condition.** Status indication by means of LED, sensor, voltage and temperature monitoring.



Sendix absolute



Fast

- **High accuracy:** Update rate of the whole position value above 100 kHz.
- **High productivity due to very short regulation cycles:** Clock rate with SSI up to 2 MHz, with BiSS up to 10 MHz.
- **High-resolution feedback system achievable in real-time:** SinCos incremental outputs.

Versatile

- **Connections for every application:** Cable, M23 and M12 connector.
- **Open interfaces ensure flexibility and independence:** SSI or BiSS with Sine-Cosine-Option incremental track RS422.
- Multiple mounting brackets for easy installation.
- **Status LED and set key available.**
- **Quick, simple on site start-up:** Set key or preset by means of a control input.

Mechanical characteristics:

Shaft version:

Max. speed without shaft sealing (IP65) up to 158°F (70°C):	12,000 RPM, continuous 10,000 RPM
Max. speed without shaft sealing (IP65) up to Tmax:	8,000 RPM, continuous 5,000 RPM
Max. speed with shaft sealing (IP67) up to 158°F (70°C):	11,000 RPM, continuous 9,000 RPM
Max. speed with shaft sealing (IP67) up to Tmax:	8,000 RPM, continuous 5,000 RPM

Hollow shaft version:

Max. speed without shaft sealing (IP65) up to 158°F (70°C):	9,000 RPM, continuous 6,000 RPM
Max. speed without shaft sealing (IP65) up to Tmax:	6,000 RPM, continuous 3,000 RPM
Max. speed with shaft sealing (IP67) up to 158°F (70°C):	8,000 RPM, continuous 4,000 RPM
Max. speed with shaft sealing (IP67) up to Tmax:	4,000 RPM, continuous 2,000 RPM

Starting torque without shaft seal (IP65):	Shaft version: < 1.4 oz-in (< 0.01 Nm) Hollow shaft version: < 4.25 oz-in (< 0.03 Nm)
--	--

Starting torque with shaft seal (IP67):	< 7 oz-in (< 0.05 Nm)
---	-----------------------

Moment of inertia:	Shaft version: 0.219 oz-in ² (4.0 x 10 ⁻⁶ kgm ²) Hollow shaft version: 0.383 oz-in ² (7.0 x 10 ⁻⁶ kgm ²)
--------------------	---

Radial load capacity of shaft:	40 lbs (178 N)
--------------------------------	----------------

Axial load capacity of shaft:	40 lbs (178 N)
-------------------------------	----------------

Weight:	approx. 1 lb (0.45 kg)
---------	------------------------

Protection acc. to EN 60 529:	Housing: IP67, Shaft: IP65, opt. IP67
-------------------------------	---------------------------------------

EX approval for hazardous areas:	optional zone 2 and 22
----------------------------------	------------------------

Working temperature:	-40 to +194°F (-40 to +90°C)
----------------------	------------------------------

Materials:	Shaft: stainless steel, Flange: aluminum, Housing: die cast zinc, Cable: PVC
------------	---

Shock resistance acc. to DIN-IEC 68-2-27:	> 250 g (> 2,500 m/s ²), 6 ms
---	---

Vibration resistance acc. to DIN-IEC 68-2-6:	> 10 g (> 100 m/s ²), 55-2,000 Hz
--	---

¹⁾ Cable versions: -22 to +167°F (-30 to +75°C)

Sendix absolute, multiturn type 5863 (shaft) / 5883 (hollow shaft)

SSI/BiSS

General electrical characteristics:

Supply voltage:	5 VDC + 5% or 10-30 VDC
Current consumption (without output load):	5 VDC: max. 75 mA, 24 VDC: max. 25 mA
Reverse polarity protection at power supply (+V):	Yes (only 10-30 VDC)
UL certified:	File 224618
Conforms to CE requirements according to EN 61000-6-1, EN 61000-6-4 and EN 61000-6-3	
RoHS compliant according to EU guideline 2002/95/EG	

General interface characteristics:

Output driver:	RS485 Transceiver type
Permissible load/channel:	max. + 20 mA
Signal level high:	typ. 3.8 V
Signal level low at	typ. 1.3 V, $I_{load} = 20$ mA:
Short-circuit proof outputs:	Yes ¹⁾

Interface characteristics SSI:

Singleturn resolution:	10-14 bits and 17 bits ²⁾
Number of revolutions:	4096 (12 bits)
Code:	Binary or Gray
SSI clock rate:	< 14 bits: 50 kHz-2 MHz
Monoflop time:	> 15 μ s ²⁾

Note:

If clock starts cycling within monoflop time, a second data transfer starts with the same data. If clock starts cycling after monoflop time, the data transfer starts with updated values. Max. update rate is dependent on clock speed, data length and monoflop time.

Time jitter (data request to position latch):	< 1 μ s up to 14 bits, < 4 μ s at 15-17 bits
Status and Parity bit:	optional on request

Interface characteristics BiSS:

Singleturn resolution:	10-14 bits and 17 bits, customer programmable ²⁾
Number of revolutions:	4096 (12 bits)
Code:	Binary
Clock rate:	up to 10 MHz

Max. update rate:	< 10 μ s, depending on clock speed and data length
-------------------	--

Time jitter (data request to position latch):	< 1 μ s
---	-------------

Note:

- Bidirectional, programmable parameters are: resolution, code, direction, alarms and warnings
- Multicycle data output, e.g. for temperature - CRC data verification

¹⁾ Short-circuit to 0 V or to output, one channel at a time, supply voltage correctly applied

²⁾ Other options upon request

SET (zero or defined value) and Direction (CW/CCW) control inputs

Input characteristics:	High active
Receiver type:	Comparator
Signal level high:	min. 60 % of V+ (Supply voltage), max: V+
Signal level low:	max. 25% of V+ (Supply voltage)
Input current:	< 0.5 mA
Min. pulse duration (SET):	10 ms
Timeout after SET input:	14 ms
Reaction Time (DIR input):	1 ms

The encoder can be set to zero at any position by means of a HIGH signal on the SET input or by pressing the optional SET key. Other preset values may be factory programmed. The SET input has a signal delay time of approximately 1 ms. Once the SET function has been triggered, the encoder requires an internal processing time of approximately 15 ms before the new position data can be read. During this time the LED is ON and the status output is at LOW.

Status output and LED

Output driver:	Open collector, internal pull up resistor 22 kOhm
Permissible load:	-20 mA
Signal level high:	+V
Signal level low:	< 1 V
Active at:	Low

The optional LED (red) and the status output serve to display various alarm or error messages. In normal operation the LED is OFF and the status output is HIGH (open-collector with int. pull-up 22k).

If the LED is ON (status output LOW) this indicates:

- Sensor error, singleturn or multiturn (soiling, glass breakage etc.)
 - LED error, failure or aging
 - Over- or under-temperature
 - Undervoltage

In the SSI mode, the fault indication can only be reset by switching off the power-supply to the device.

DIR input

A HIGH signal switches the direction of rotation from the default CW to CCW. This inverted function can also be factory-programmed. If direction is changed when the device is already switched on, then this will be interpreted as an error. The LED will come ON and the status output will switch to LOW.

Power-on delay

-3dB frequency:	400 kHz
Signal level:	1 Vpp (+ 20%)
Short-circuit proof:	Yes ¹⁾

Option incremental output (A/B), 2048 ppr:

After Power-ON the device requires a time of approx. 150 ms before valid data can be read.

Sendix absolute, multiturn type 5863 (shaft) / 5883 (hollow shaft) SSI/BiSS

Pin configuration:
Output circuit 1 or 2 and 2 control inputs, 1 status output (Connection 1, 2, 3 or 4)

Output	Common (0 V)	+V	+Clock	-Clock	+Data	-Data	ST	DIR	Status	NC	NC	NC	PE
M23 pin:	1	2	3	4	5	6	7	8	9	10	11	12	PH
Color:	WH	BN	GN	YE	GY	PK	BU	RD	BK	-	-	-	Shield

Pin configuration:
Output circuit 5 and 2 control inputs, 1 status output, voltage monitor outputs (Connection 1, 2, 3 or 4)

Output	Common (0 V)	+V	+Clock	-Clock	+Data	-Data	ST	DIR	Status	NC	0 V Sens	+V Sens	PE
M23 pin:	1	2	3	4	5	6	7	8	9	10	11	12	PH
Color:	WH	BN	GN	YE	GY	PK	BU	RD	BK	-	GY/PK	RD/BU	Shield

Pin configuration:
Output circuit 3, 4, 7 or 8 and 2 control inputs or incremental track, sine/cosine (Connection 1, 2, 3 or 4)

Output	Common (0 V)	+V	+Clock	-Clock	+Data	-Data	ST	DIR	Sin A	Sin inv A-	Cos B	Cos inv B-	PE
M23 pin:	1	2	3	4	5	6	7	8	9	10	11	12	PH
Color:	WH	BN	GN	YE	GY	PK	BU	RD	BK	VT	GY/PK	RD/BU	Shield

Pin configuration:
Output circuit 6 or 9 and sine/cosine or incremental monitor, voltage outputs (Connection 1, 2, 3 or 4)

Output	Common (0 V)	+V	+Clock	-Clock	+Data	-Data	Sin A	Sin inv A-	Cos B	Cos inv B-	0 V Sens	+V Sens	PE
M23 pin:	1	2	3	4	5	6	7	8	9	10	11	12	PH
Color:	WH	BN	GN	YE	GY	PK	BU	RD	BK	VT	GY/PK	RD/BU	Shield

Pin configuration:
Output circuit 1 or 2 and 2 control inputs (Connection 5 or 6)

Output	Common (0 V)	+V	+Clock	-Clock	+Data	-Data	ST	DIR	PE
M12 pin:	1	2	3	4	5	6	7	8	PH

Wiring diagrams:

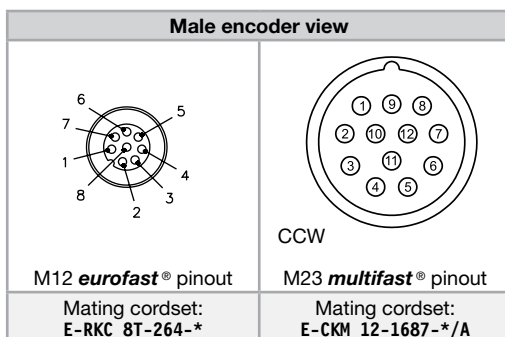

* Length in meters.



Encoder with tangential cable outlet



- Safe operation in strong magnetic fields
- Special gears with specific toothing

Sendix absolute, multiturn type 5863 (shaft) / 5883 (hollow shaft)

SSI/BiSS

Part number key: 5863 shaft version

T8.5863.XXXX.XXXX

Type	
Flange	<p>1 = clamping flange Ø 58 IP65</p> <p>2 = servo flange 58 mm, IP65</p> <p>3 = clamping flange Ø 58 mm, IP67</p> <p>4 = servo flange Ø 58 mm, IP67</p> <p>5 = square flange 2.5" / 63.5 mm, IP65</p> <p>6 = servo flange 2.5" / 63.5 mm, IP65</p> <p>7 = square flange 2.5" / 63.5 mm, IP67</p> <p>8 = servo flange 2.5" / 63.5 mm, IP67</p>
Shaft (Ø x L)	<p>1 = Ø 6 mm x 10 mm</p> <p>2 = Ø 10 mm x 20 mm</p> <p>3 = Ø 1/4" x 7/8"</p> <p>4 = Ø 3/8" x 7/8"</p>
Output circuit and supply voltage	<p>1 = 5 VDC, SSI or BiSS interface</p> <p>2 = 10-30 VDC, SSI or BiSS</p> <p>3 = 5 VDC, SSI or BiSS, and 2048 ppr SinCos</p> <p>4 = 10-30 VDC, SSI or BiSS, and 2048 ppr SinCos</p> <p>5 = 5 VDC, SSI or BiSS, with sensor outputs for monitoring the supply voltage on the encoder</p> <p>6 = 5 VDC, SSI or BiSS, and 2048 ppr SinCos, with sensor outputs for monitoring the supply voltage on the encoder</p> <p>7 = 5 VDC, SSI or BiSS and 2048 ppr-incremental track RS422 (TTL-comp.)</p> <p>8 = 10-30 VDC, SSI or BiSS and 2048 ppr-incremental track RS422 (TTL-comp.)</p> <p>9 = 5 VDC, SSI or BiSS and 2048 ppr-incremental track RS422 (TTL-comp.), with sensor outputs for monitoring the supply voltage on the encoder</p>

Options (service)	<p>1 = no option</p> <p>2 = status LED</p> <p>3 = SET button and status LED</p>						
Input/output ¹⁾	<p>2 = SET, DIR inputs additional status output</p>						
Resolution ³⁾	<table border="0"> <tr> <td>A = 10 bits ST + 12 bits MT</td> <td>3 = 13 bits ST + 12 bits MT</td> </tr> <tr> <td>1 = 11 bits ST + 12 bits MT</td> <td>4 = 14 bits ST + 12 bits MT</td> </tr> <tr> <td>2 = 12 bits ST + 12 bits MT</td> <td>7 = 17 bits ST + 12 bits MY</td> </tr> </table>	A = 10 bits ST + 12 bits MT	3 = 13 bits ST + 12 bits MT	1 = 11 bits ST + 12 bits MT	4 = 14 bits ST + 12 bits MT	2 = 12 bits ST + 12 bits MT	7 = 17 bits ST + 12 bits MY
A = 10 bits ST + 12 bits MT	3 = 13 bits ST + 12 bits MT						
1 = 11 bits ST + 12 bits MT	4 = 14 bits ST + 12 bits MT						
2 = 12 bits ST + 12 bits MT	7 = 17 bits ST + 12 bits MY						
Code	<p>B = SSI, binary</p> <p>C = BiSS, binary</p> <p>G = SSI, gray</p>						
Type of connection	<p>1 = axial cable (1 m PVC)</p> <p>2 = radial cable (1 m PVC)</p> <p>3 = axial 12-pin M23 multifast® connector</p> <p>4 = radial 12-pin M23 multifast connector</p> <p>5 = axial 8-pin M12 eurofast® connector</p> <p>6 = radial 8-pin M12 eurofast connector</p>						

¹⁾ Resolution, preset value and counting direction factory-programmable

Part number key: 5883 hollow shaft version

T8.5883.XXXX.XXXX

Type							
Flange	<p>1 = flange with torque stop IP65</p> <p>2 = flange with torque stop IP67</p> <p>3 = flange with flex mount pitch circle Ø 65, IP65</p> <p>4 = flange with flex mount pitch circle Ø 65, IP67</p> <p>5 = flange with slotted flex mount pitch circle Ø 63, IP65</p> <p>6 = flange with slotted flex mount pitch circle Ø 63, IP67</p>						
Hollow shaft	<table border="0"> <tr> <td>3 = Ø 10 mm</td> <td>6 = Ø 15 mm (blind hollow shaft, 30 mm depth)</td> </tr> <tr> <td>4 = Ø 12 mm</td> <td>8 = Ø 9.52 mm (3/8")</td> </tr> <tr> <td>5 = Ø 14 mm</td> <td>9 = Ø 12.7 mm (1/2")</td> </tr> </table>	3 = Ø 10 mm	6 = Ø 15 mm (blind hollow shaft, 30 mm depth)	4 = Ø 12 mm	8 = Ø 9.52 mm (3/8")	5 = Ø 14 mm	9 = Ø 12.7 mm (1/2")
3 = Ø 10 mm	6 = Ø 15 mm (blind hollow shaft, 30 mm depth)						
4 = Ø 12 mm	8 = Ø 9.52 mm (3/8")						
5 = Ø 14 mm	9 = Ø 12.7 mm (1/2")						
Output circuit and supply voltage	<p>1 = 5 VDC, SSI or BiSS interface</p> <p>2 = 10-30 VDC, SSI or BiSS</p> <p>3 = 5 VDC, SSI or BiSS, and 2048 ppr SinCos</p> <p>4 = 10-30 VDC, SSI or BiSS, and 2048 ppr SinCos</p> <p>5 = 5 VDC, SSI or BiSS, with sensor outputs for monitoring the supply voltage on the encoder</p> <p>6 = 5 VDC, SSI or BiSS, and 2048 ppr SinCos, with sensor outputs for monitoring the supply voltage on the encoder</p> <p>7 = 5 VDC, SSI or BiSS and 2048 ppr-incremental track RS422 (TTL-comp.)</p> <p>8 = 10-30 VDC, SSI or BiSS and 2048 ppr-incremental track RS422 (TTL-comp.)</p> <p>9 = 5 VDC, SSI or BiSS and 2048 ppr-incremental track RS422 (TTL-comp.), with sensor outputs for monitoring the supply voltage on the encoder</p>						

Options (service)	<p>1 = no option</p> <p>2 = status LED</p> <p>3 = SET button and status LED</p>						
Input/output ¹⁾	<p>2 = SET, DIR inputs additional status output</p>						
Resolution ¹⁾	<table border="0"> <tr> <td>A = 10 bits ST + 12 bits MT</td> <td>3 = 13 bits ST + 12 bits MT</td> </tr> <tr> <td>1 = 11 bits ST + 12 bits MT</td> <td>4 = 14 bits ST + 12 bits MT</td> </tr> <tr> <td>2 = 12 bits ST + 12 bits MT</td> <td>7 = 17 bits ST + 12 bits MY</td> </tr> </table>	A = 10 bits ST + 12 bits MT	3 = 13 bits ST + 12 bits MT	1 = 11 bits ST + 12 bits MT	4 = 14 bits ST + 12 bits MT	2 = 12 bits ST + 12 bits MT	7 = 17 bits ST + 12 bits MY
A = 10 bits ST + 12 bits MT	3 = 13 bits ST + 12 bits MT						
1 = 11 bits ST + 12 bits MT	4 = 14 bits ST + 12 bits MT						
2 = 12 bits ST + 12 bits MT	7 = 17 bits ST + 12 bits MY						
Code	<p>B = SSI, binary</p> <p>C = BiSS, binary</p> <p>G = SSI, gray</p>						
Type of connection	<p>2 = radial cable (1 m PVC)</p> <p>4 = radial 12-pin M23 multifast connector</p> <p>6 = radial 8-pin M12 eurofast connector</p> <p>E = tangential cable outlet (1 m PVC cable)</p>						

¹⁾ Resolution, preset value and counting direction factory-programmable

Accessories:

- See page J1, Connectivity, for cables and connectors
- See page E1, Accessories, for mounting attachments and couplings

Sendix absolute, multiturn type 5863 (shaft) / 5883 (hollow shaft) SSI/BiSS

Dimensions: 5863 shaft version

5863 flanges 5 & 7
Cable connection 1 & 2

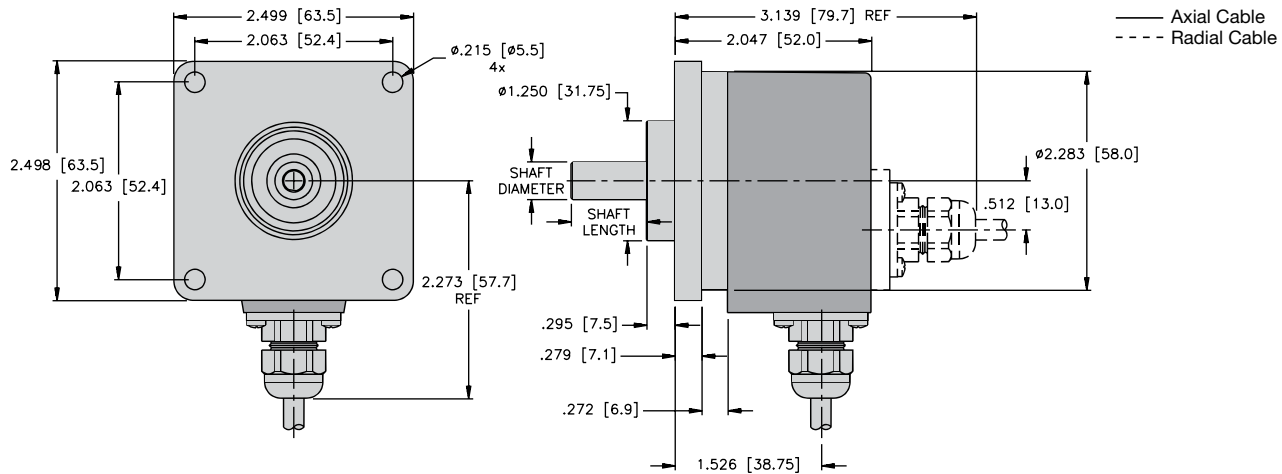

5863 flanges 1 & 3
M23 multifast® connection 3 & 4

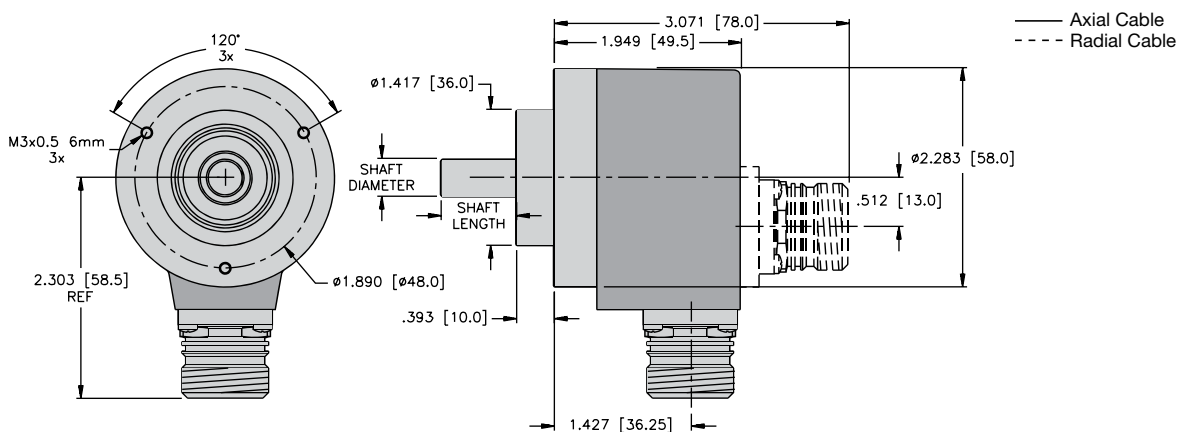

5863 flanges 2 & 4
M12 eurofast® connection 5 & 6

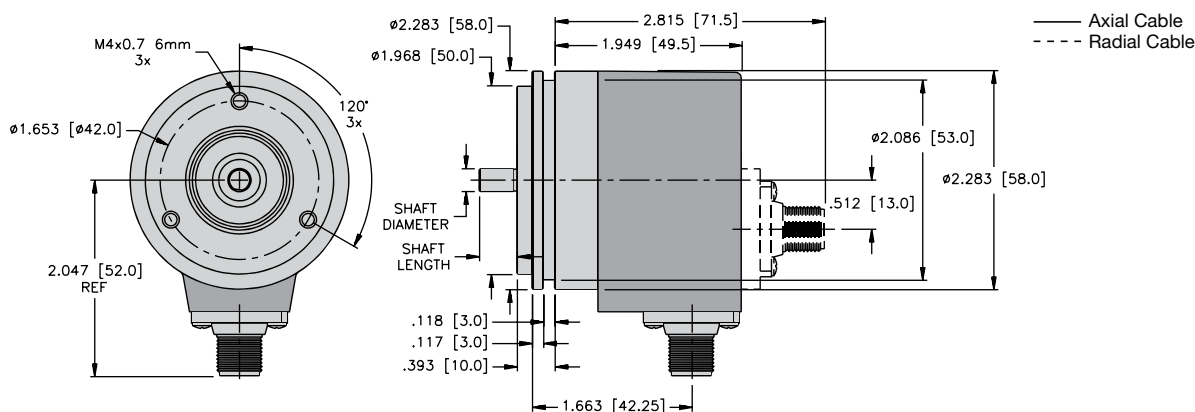

Sendix absolute, multiturn type 5863 (shaft) / 5883 (hollow shaft) SSI/BiSS

Dimensions: 5863 shaft version

5863 flanges 6 & 8
M12 eurofast® connection 5 & 6

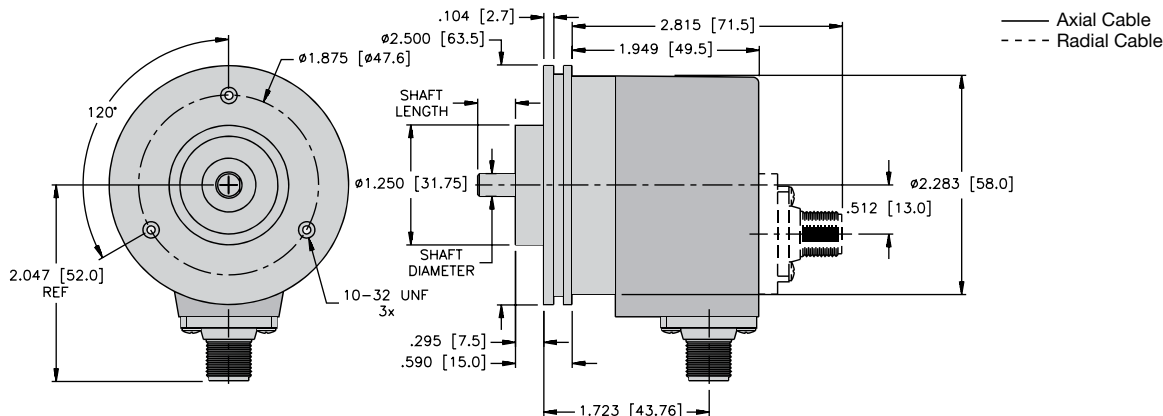

Dimensions: 5883 hollow shaft version

5883 flanges 3 & 4
Cable connection 2

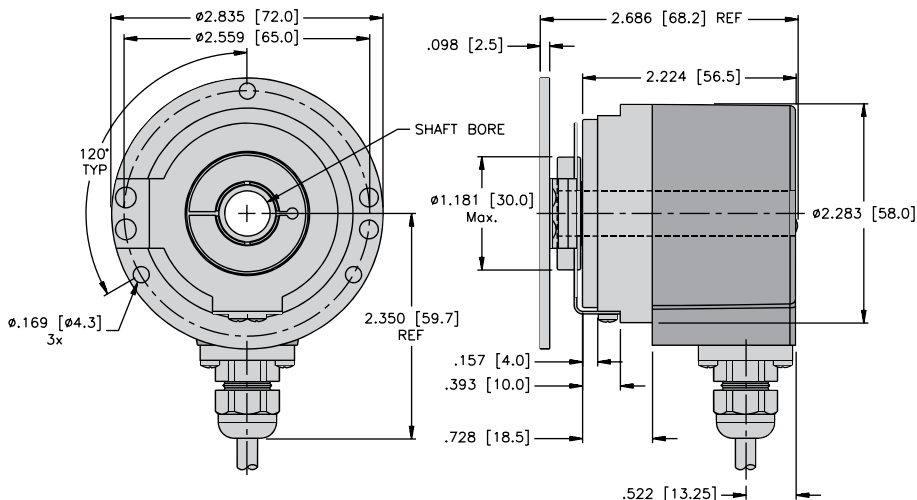

5883 flanges 5 & 6
M23 multifast® connection 4

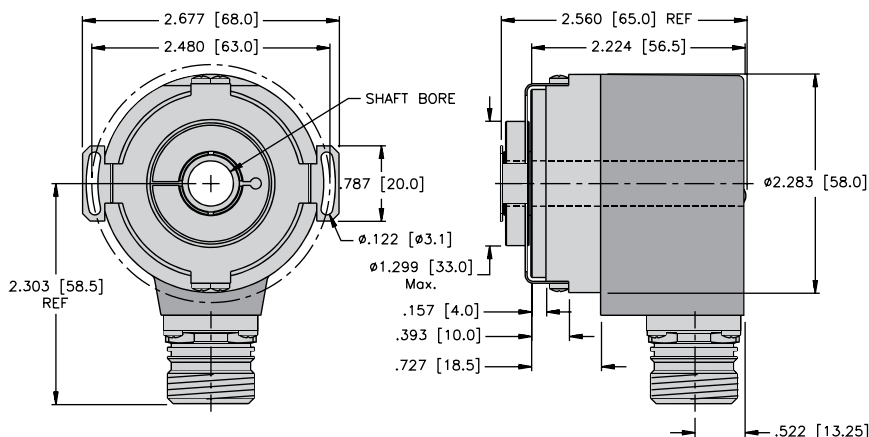

Absolute Encoders

Sendix absolute, multiturn type 5863 (shaft) / 5883 (hollow shaft) SSI/BiSS

Dimensions: 5883 hollow shaft version

5883 flanges 1 & 2
M12 eurofast® connection

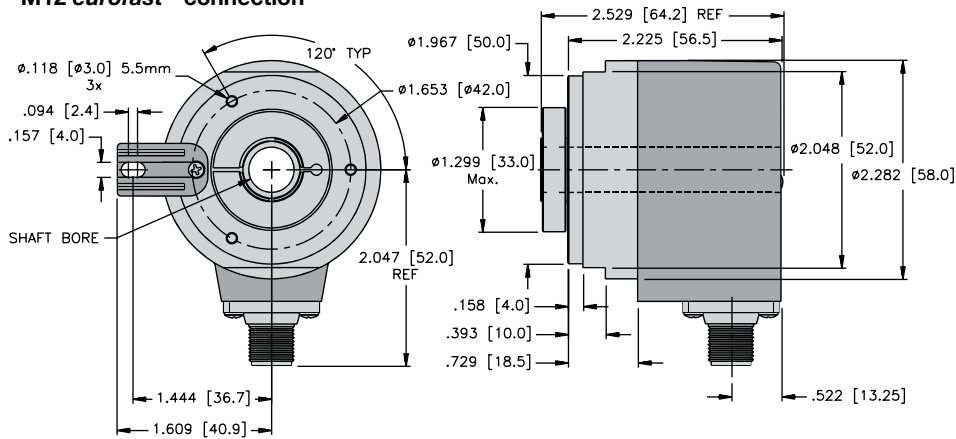

5883 flanges 1 & 2
Cable connection E

