

3 and 5-Wire eurofast® Cordsets, Reverse Key (B-Code)

- Right Angle Male Connector
- NEMA 1, 3, 4, 6P and IEC IP 68 Protection
- 250 V, 4 A

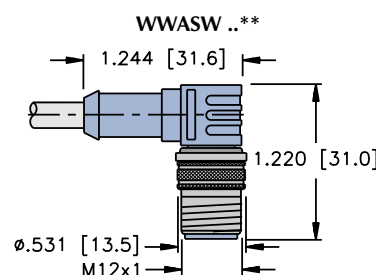

Housing Style	Part Number	Cable	Features	Pinout
	WWASW 4T-*/S626	AWM PVC Grey 3x20 AWG 105°C 5.2 mm OD Cable #RF20017- [†] M [†]	<i>flexlife</i> ®	1. BN 2. BU 4. GN/YE
	WWASW 4T-2/S821	AWM PVC Yellow 3x18 AWG 80°C, 250°C short term 5.7 mm OD	<i>Weld Flash Immune, High Temp Immune</i>	1. RD 2. RD/WH 4. GN
	WWASW 4.5T-*	AWM PVC Grey 4x22, 1x20 AWG 105°C 5.7 mm OD Cable #RF50563- [†] M [†]	<i>flexlife</i>	1. BN 2. WH 3. BU 4. BK 5. GN/YE
	WWASW 4.5T-*/S101	AWM TPE Grey 5x22 AWG 105°C 5.7 mm OD Cable #RF50909- [†] M [†]	<i>Flexlife-10, High Flex - Over 10 Million Cycles</i>	1. BN 2. WH 3. BU 4. BK 5. CY
	WWASW 4.5T-*/S618	AWM PVC Grey 5x22 AWG 105°C 5.7 mm OD Cable #RF50609- [†] M [†]	<i>EMI/RFI Protection</i>	
	WWASW 4.5T-*/S653	AWM PVC Grey 4x22 AWG 105°C 5.2 mm OD Cable #RF50577- [†] M [†]	<i>EMI/RFI Protection</i>	1. BN 2. WH 3. BU 4. BK 5. Drain

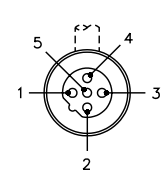

* Length in meters. Standard cable lengths are 2, 4, 6, 8 and 10 meters. Consult factory for other lengths.
 ** Standard coupling nut material is nickel plated brass "WWASW.."; "WWASKW.." indicates nylon and "WWASVW.." indicates 316 stainless steel.
[†] Section N for *reelfast*® cable information.