

26 and 28-Pin M27 *multifast*® Receptacles, Front Mount

- Female Receptacles
- For use with Junction Box Home Run Cables
- IEC IP 65 Protection



Housing Style	Part Number	Lead Specs.	Application	Pinout	
	DKF 26-25-*	AWM PVC Yellow 25x22 AWG 105°C 8.0 mm OD 150 V, 8.0 A	25-wire applications	1. BN 14. WH 2. WH/GY 15. BU 3. BU/GY 16. BK/GY 4. BN/GY 17. BN/OG 5. BK/YE 18. WH/OG 6. WH/YE 19. BK/OG 7. BU/YE 20. BK/GN 8. BN/YE 21. WH/GN 9. BK/RD 22. BU/GN 10. WH/RD 23. BN/GN 11. BU/RD 24. BU/OG 12. BN/RD 25. GN/YE 13. BK 26. N/C	
	DKF 28-27-*	AWM PVC Yellow 27x22 AWG 105°C 8.0 mm OD 60 V, 3.0 A	27-wire applications	1. BN 15. BU 2. WH/GY 16. BK/GY 3. BU/GY 17. BN/OG 4. BN/GY 18. WH/OG 5. BK/YE 19. BK/OG 6. WH/YE 20. BK/GN 7. BU/YE 21. WH/GN 8. BN/YE 22. BU/GN 9. BK/RD 23. BN/GN 10. WH/RD 24. BU/OG 11. BU/RD 25. GN/YE 12. BN/RD 26. GY 13. BK 27. OG 14. WH 28. N/C	

See page H50 for dimensional drawings.

* Length in meters. Standard lead length is 1 meter. Consult factory for other lengths.
To specify PVC jacketed cable, add "/S717" to the end of the part number.

multifast® Receptacles

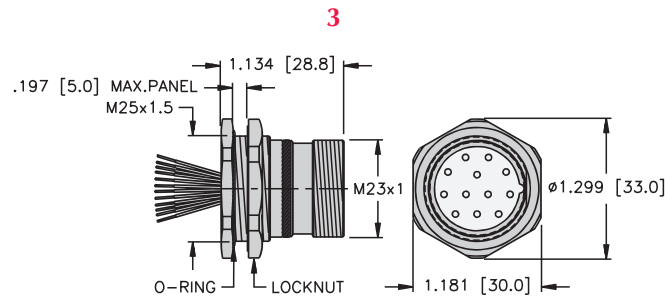

Typical panel cutout is 25.4 x 24.3x25.4 mm.

CS(K)FD

Page H59 - H66

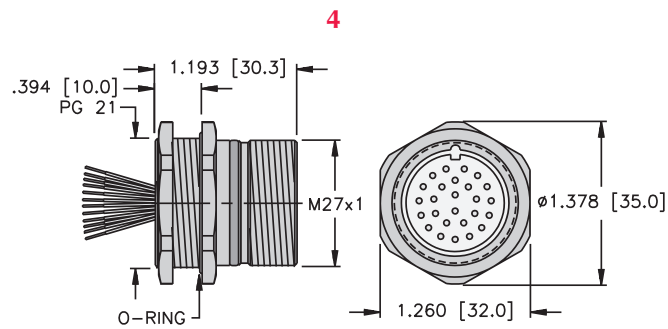

Typical panel cutout is 28.3 mm.

DS(K)F

Page H67 - H68