

# BI8-M18-LI-EXI-H1141

## Inductive Sensor – With Analog Output

### Features

- Threaded barrel, M18 x 1
- Chrome-plated brass
- 2-wire, 14...30 VDC
- Analog output
- 4...20 mA
- M12 x 1 male connector
- ATEX category II 1 G, Ex-zone 0
- ATEX category II 2 D, Ex-zone 21

### Wiring diagram

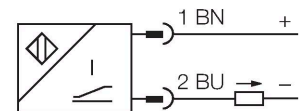

### Functional principle

Inductive sensors with analog output from TURCK accomplish simple control tasks. They provide a distance-proportional current signal. Determined by the technology used, the maximum load in 2-wire technology is influenced by the sensor's operating voltage. The load's resistance must be selected so that the supply voltage of the sensor does not fall below 14 volts.

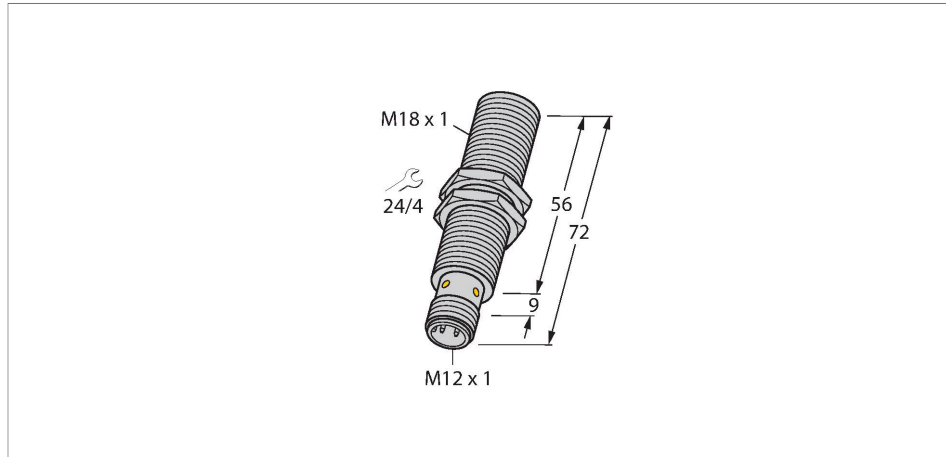
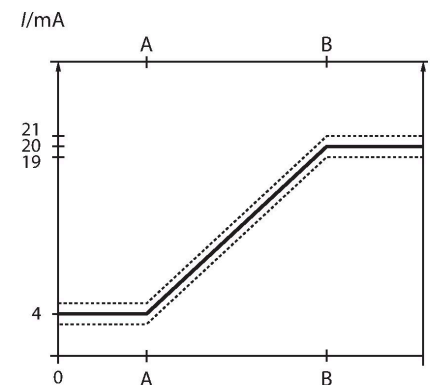

### Technical data

|   |   |
|---|---|
| Type                                      | BI8-M18-LI-EXI-H1141  |
| ID  | 1535604   |
| <b>General data</b>                       |   |
| Measuring range                           | 1...5 mm  |
| Mounting conditions                       | Flush   |
| Secured operating distance                | $\leq (0.81 \times S_n)$ mm   |
| Correction factors                        | St37 = 1; Al = 0.3; stainless steel = 0.7; Ms = 0.4                 |
| Repeatability                             | $\leq 1\%$ of measuring range  A - B <br>0.5 %, after warm-up 0.5 h |
| Linearity deviation                       | $\leq 5\%$  |
| Temperature drift                         | $\leq \pm 0.06\%$ /K  |
| <b>Electrical data</b>                    |   |
| Operating voltage                         | 14...30 VDC<br>at the electrical connection of the sensor           |
| Residual ripple                           | $\leq 10\%$ $U_{ss}$  |
| Isolation test voltage                    | $\leq 0.5$ kV   |
| Short-circuit protection                  | yes   |
| Wire breakage/Reverse polarity protection | no / Complete   |
| Output function                           | 2-wire, Analog output   |
| Current output                            | 4...20 mA   |
| Load resistance current output            | $\leq [(U_b - 14 \text{ V}) / 20 \text{ mA}]$                       |
| Measuring sequence frequency              | 200 Hz  |
| Approval acc. to                          | KEMA 03 ATEX 1122 X Output no. 5                                    |

BI8-M18-LI-EXI-H1141 | 11/07/2023 15-03 | technical changes reserved

## Technical data

|  |  |
|--|--|
| Internal capacitance (C)/inductance (L.) | 0 nF/0 $\mu$ H   |
| Device marking                           | $\text{Ex}$ II 1 G Ex ia IIC T6 Ga / II 2 D Ex ia IIIC<br>T85°C Db<br>(max. $U_i$ = 30 V, $I_i$ = 120 mA, $P_i$ = 600mW) |
| <b>Mechanical data</b>                   |  |
| Design                                   | Threaded barrel, M18 x 1   |
| Dimensions                               | 72 mm  |
| Housing material                         | Metal, CuZn, Chrome-plated   |
| Active area material                     | Plastic, PA12-GF30   |
| Max. tightening torque of housing nut    | 25 Nm  |
| Electrical connection                    | Connector, M12 x 1   |
| <b>Environmental conditions</b>          |  |
| Ambient temperature                      | -25...+70 °C   |
|  | For explosion hazardous areas see instruction leaflet  |
| Vibration resistance                     | 55 Hz (1 mm)   |
| Shock resistance                         | 30 g (11 ms)   |
| Protection class                         | IP67   |
| MTTF                                     | 751 years acc. to SN 29500 (Ed. 99) 40 °C  |

## Mounting instructions

### Mounting instructions/Description



|                        |         |
|------------------------|---------|
| Distance D             | 2 x B   |
| Distance W             | 12 mm   |
| Distance T             | 3 x B   |
| Distance S             | 1.5 x B |
| Distance G             | 24 mm   |
| Diameter active area B | Ø 18 mm |

## Accessories

BST-18B

6947214

Mounting clamp for threaded barrel sensors, with dead-stop; material: PA6

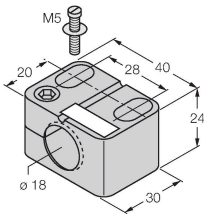

QM-18

6945102

Quick-mount bracket with dead-stop; material: Chrome-plated brass. Male thread M24 x 1.5. Note: The switching distance of the proximity switches may change when using quick-mount brackets.

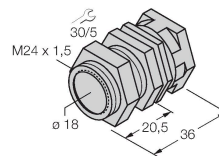

MW-18

6945004

Mounting bracket for threaded barrel sensors; material: Stainless steel A2 1.4301 (AISI 304)



BSS-18

6901320

Mounting clamp for smooth and threaded barrel sensors; material: Polypropylene

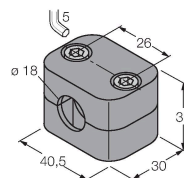

IM33-11EX-HI

7506443

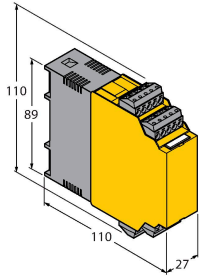

Isolating transducers; 1-channel; power supply of 2-wire measuring transducers with HART communication as well as connection of active 2-wire and passive 3-wire transmitters

## Instructions for use

### Intended use

This device fulfills the directive 2014/34/EC and is suited for use in explosion hazardous areas according to EN 60079-0:2018 + A11 and EN 60079-11:2012. In order to ensure correct operation to the intended purpose it is required to observe the national regulations and directives.

### For use in explosion hazardous areas conform to classification

II 1 G and II 2 D (Group II, Category 1 G, electrical equipment for gas-atmospheres and category 2 D, electrical equipment for dust atmospheres)

### Marking (see device or technical data sheet)

⊕ II 1 G Ex ia IIC T6 Ga und ⊕ II 2 D Ex ia IIIC T85°C Db acc. to EN 60079-0, -11

### Local admissible ambient temperature

-25...+65 °C

### Installation/Commissioning

These devices may only be installed, connected and operated by trained and qualified staff. Qualified staff must have knowledge of protection classes, directives and regulations concerning electrical equipment designed for use in explosion hazardous areas. Please verify that the classification and the marking on the device comply with the actual application conditions.

This device is only suited for connection to approved Exi circuits according to EN 60079-0 and EN 60079-11. Please observe the maximum admissible electrical values. After connection to other circuits the sensor may no longer be used in Exi installations. When interconnected to (associated) electrical equipment, it is required to perform the "Proof of intrinsic safety" (EN60079-14).

### Installation and mounting instructions

Avoid static charging of cables and plastic devices. Please only clean the device with a damp cloth. Do not install the device in a dust flow and avoid build-up of dust deposits on the device. If the devices and the cable could be subject to mechanical damage, they must be protected accordingly. They must also be shielded against strong electro-magnetic fields. The pin configuration and the electrical specifications can be taken from the device marking or the technical data sheet. In order to avoid contamination of the device, please remove possible blanking plugs of the cable glands or connectors only shortly before inserting the cable or opening the cable socket.

### Service/Maintenance

Repairs are not possible. The approval expires if the device is repaired or modified by a person other than the manufacturer. The most important data from the approval are listed.