

BI4-EM12E-AN45XLD-H1141

Inductive Sensor – For Use in Vehicle Board Nets

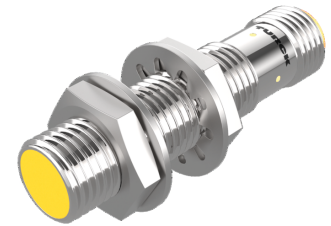
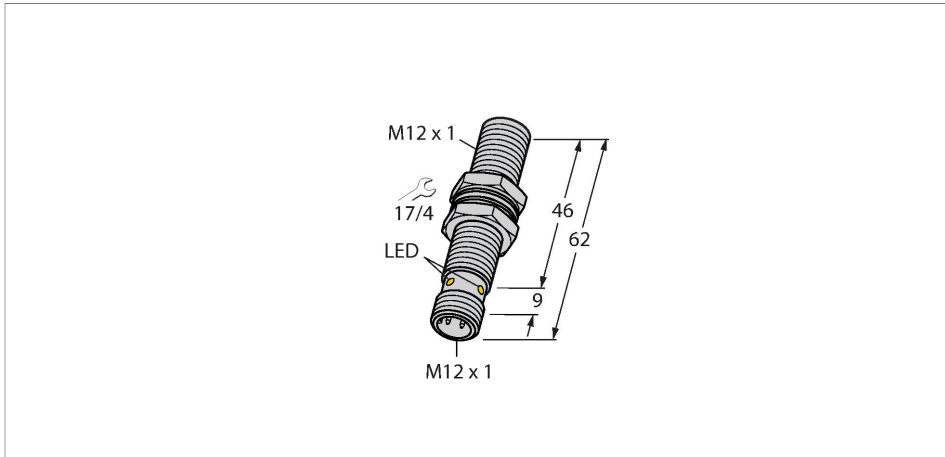

Technical data

Type	BI4-EM12E-AN45XLD-H1141
ID	1584003
General data	
Rated switching distance	4 mm
Mounting conditions	Flush
Secured operating distance	$\leq (0.81 \times S_n)$ mm
Correction factors	St37 = 1; Al = 0.3; stainless steel = 0.7; Ms = 0.4
Repeat accuracy	≤ 2 % of full scale
Temperature drift	$\leq \pm 10$ % $\leq \pm 15$ %, ≤ -25 °C v $\geq +70$ °C
Hysteresis	3...15 %
Electrical data	
Operating voltage	8.6...65 VDC
Residual ripple	≤ 10 % U_{ss}
DC rated operational current	≤ 200 mA
No-load current	15 mA
Residual current	≤ 0.1 mA
Isolation test voltage	≤ 0.5 kV
Short-circuit protection	yes / Cyclic
Voltage drop at I_o	≤ 1.8 V
Wire breakage/Reverse polarity protection	yes / Complete
Output function	3-wire, NO contact, NPN
Load-dump protection (DIN ISO 7637-2)	Severity degree IV/Level 4

Features

- Threaded barrel, M12 x 1
- Stainless steel, 1.4301
- For vehicle board nets, 12 V and 24 V
- Increased interference immunity 100 V/m radiated acc. ISO 11452-4 and 100 mA BCI acc. to ISO 11452-2
- Load-dump protection acc. to DIN ISO 7637-2 (SAE J 113-11)
- Extended temperature range
- High protection class IP68/IP69K
- Protection against salt spray and rapid temperature change
- Laser engraved label, permanently legible
- DC 3-wire, 8.4...65 VDC
- NO contact, NPN output
- M12 x 1 male connector

Wiring diagram

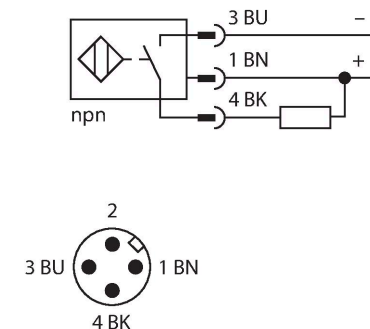

Functional principle

BI4-EM12E-AN45XLD-H1141 | 11/07/2023 14-28 | technical changes reserved

Technical data

Switching frequency	2 kHz
Mechanical data	
Design	Threaded barrel, M12 x 1
Dimensions	62 mm
Housing material	Stainless steel, 1.4301 (AISI 304)
Active area material	Plastic, PA12-GF30
Max. tightening torque of housing nut	10 Nm
Electrical connection	Connector, M12 × 1
Environmental conditions	
Ambient temperature	-40...+85 °C
Temperature changes (EN60068-2-14)	-40... +85 °C; 20 cycles
Vibration resistance	55 Hz (1 mm)
Vibration resistance (EN 60068-2-6)	20 g; 10...3000 Hz; 50 cycles; 3 axes
Shock resistance	30 g (11 ms)
Shock resistance (EN 60068-2-27)	150 g; 6 ms ½ sine; 3 × each; 3 axes
Continuous shock resistance (EN 60068-2-29)	100 g; 11 ms ½ sine; 3 × each; 3 axes
Salt spray test (EN 60068-2-52)	Severity degree 5 (4 test cycles)
Protection class	IP68 IP69K
MTTF	2283 years acc. to SN 29500 (Ed. 99) 40 °C
Switching state	LED, Yellow

Maximum reliability even under the most extreme environmental conditions is guaranteed by our sensors for mobile applications.

TURCK's inductive sensors for extremely hostile industrial environments not only meet, but even exceed the requirements of the protection classes IP68 and IP69.

Applied in vehicles for road construction or in agricultural machines, these sensors excel in high vibration and shock resistance and they withstand fast temperature cycles.

12 V Bordnet						
Impulse	1	2	3a	3b	4	5
Severity level	IV	IV	IV	IV	IV	IV
Failure criterion	C	C	A	A	C	C

24 V Bordnet						
Impulse	1	2	3a	3b	4	5
Severity level	III	IV	IV	IV	III	IV
Failure criterion	C	C	A	A	A	C

Mounting instructions

Mounting instructions/Description



Distance D 2 x B

Distance W 3 x Sn

Distance T 3 x B

Distance S 1.5 x B

Distance G 6 x Sn

Diameter active area B \varnothing 12 mm

Accessories

BST-12B

6947212

Mounting clamp for threaded barrel sensors, with dead-stop; material: PA6

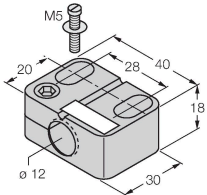

QM-12

6945101

Quick-mount bracket with dead-stop; material: Chrome-plated brass. Male thread M16 x 1. Note: The switching distance of the proximity switches may change when using quick-mount brackets.

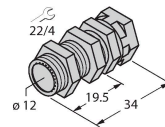

MW-12

6945003

Mounting bracket for threaded barrel sensors; material: Stainless steel A2 1.4301 (AISI 304)

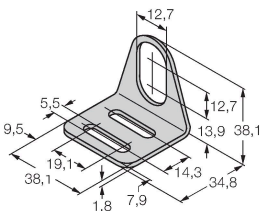

BSS-12

6901321

Mounting clamp for smooth and threaded barrel sensors; material: Polypropylene

