

NI25-CQ40/S1102 10M

Inductive Sensor – With Increased Temperature Range

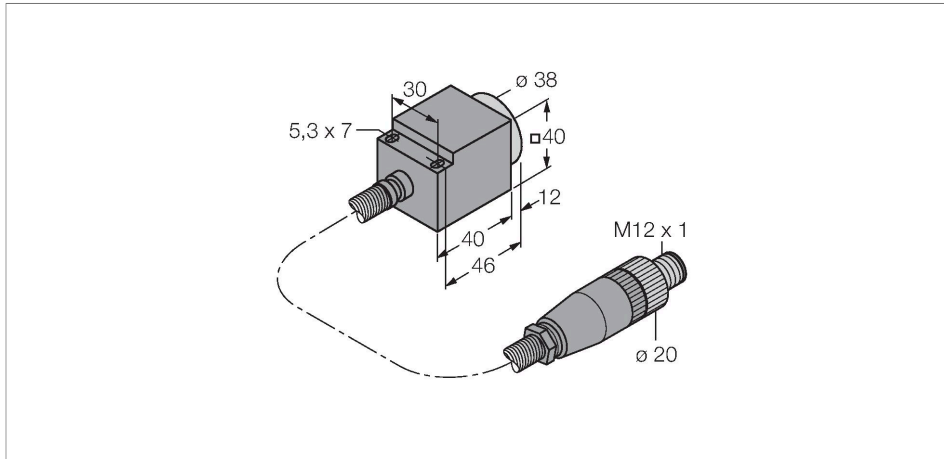

Features

- Rectangular, height 40 mm
- Sensor housing, Aluminium
- Plastic, PEEK
- Aluminium cable sheath
- For temperatures up to +250 °C
- Functions only with signal processor EM30-AP6X2-H1141/S1102
- Switchpoint adjusted at the processing unit
- 3-wire connection to the processor

Wiring diagram

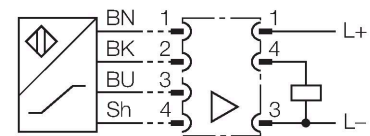

Technical data

Type	NI25-CQ40/S1102 10M
ID	1602403
Special version	S1102 corresponds to: Ambient temperature up to 250 °C
General data	
Rated switching distance	25 mm
Mounting conditions	Non-flush, partially embeddable
Secured operating distance	$\leq (0.81 \times S_n)$ mm
Correction factors	St37 = 1; Al = 0.3; stainless steel = 0.7; Ms = 0.4
Repeat accuracy	≤ 2 % of full scale
Hysteresis	3...15 %
Electrical data	
Output function	NO contact, PNP
Mechanical data	
Design	Rectangular, CQ40
Dimensions	52 x 40 x 40 mm
Housing material	Plastic, AL
Active area material	PEEK
Electrical connection	Connector, M12 x 1 max. connector temperature -20...+70°C
Cable quality	\varnothing 3.7 mm, PTFE, FEP, 10 m Al cable sheath, \varnothing 8 mm
Core cross-section	3 x 0.34 mm ²

Functional principle

The sensors must be operated with an EM30-AP6X2-H1141/S1102 signal processor. The switching distance is set using a potentiometer (continuous) on the signal processor. This is located under a cover screw next to the LED. Where possible, the switching distance must be set at operating temperature. When setting the switching distance at room temperature, the temperature sensitivity of the sensor system must be taken into account.

Setting:

1. Place the target (steel, min. 1 mm thick, square, edge length min. 3x rated switching distance) at a safe switching distance in front of the sensor
2. Turn the potentiometer counterclockwise until the LED lights up green
3. Turn the potentiometer clockwise until the LED lights up yellow
4. Perform functional checks in the operating state

Technical data

Environmental conditions	
Ambient temperature	0...+250 °C
Vibration resistance	55 Hz (1 mm)
Shock resistance	30 g (11 ms)
Protection class	IP60
MTTF	1685 years acc. to SN 29500 (Ed. 99) 40 °C

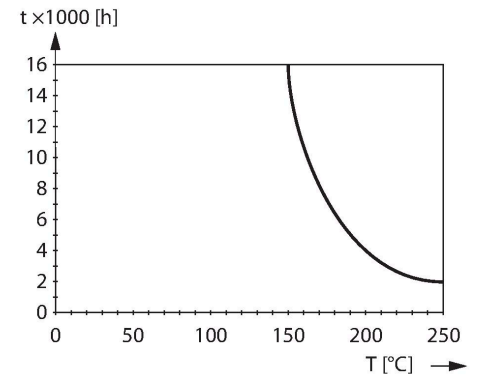

Mounting instructions

Mounting instructions/Description		
	Distance D	2 x B
	Distance W	3 x Sn
	Distance S	1.5 x B
	Distance G	6 x Sn
	Distance N	2 x Sn
	Distance A	1 x Sn
	Width active area B	40 mm

1-side mounting on metal without modification of the switching distance

Accessories

EM30-AP6X2-H1141/S1102	1602411
	<p>Signal processor for 250 °C sensor; housing material: Stainless steel 1.4571; protection class: IP67; function display: LED/yellow; operating voltage display: LED/green; ambient temperature: -20...+70 °C</p>