

NI4-S12-AP7X/S100

Inductive Sensor – With Increased Temperature Range

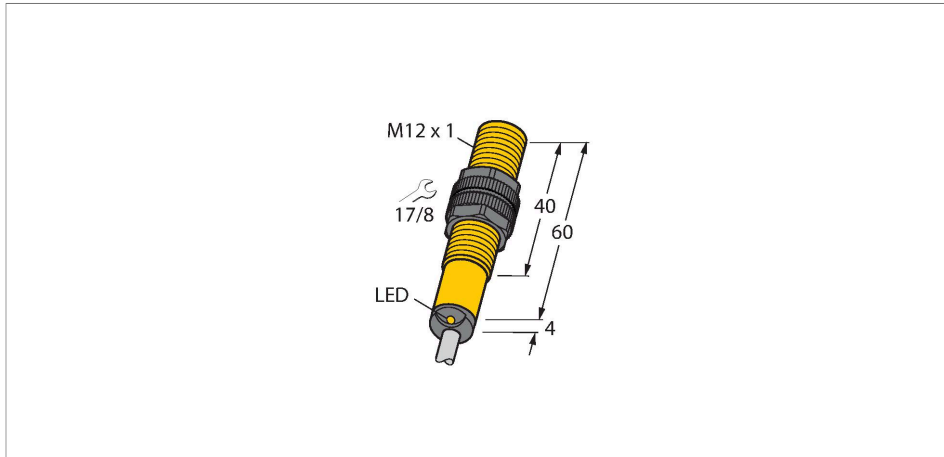

Features

- Threaded barrel, M12 x 1
- Plastic, PA12-GF30
- Temperatures up to +100 °C
- DC 3-wire, 10...30 VDC
- NO contact, PNP output
- Cable connection

Wiring diagram

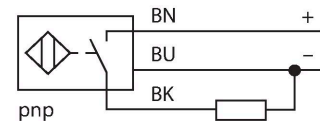

Technical data

Type	NI4-S12-AP7X/S100
ID	17681
Special version	S100 corresponds to: Maximum ambient temperature = 100 °C
General data	
Rated switching distance	4 mm
Mounting conditions	Non-flush
Secured operating distance	≤ (0.81 × S _n) mm
Correction factors	St37 = 1; Al = 0.3; stainless steel = 0.7; Ms = 0.4
Repeat accuracy	≤ 2 % of full scale
Temperature drift	≤ ±10 % ≤ ± 20 %, ≥ +70 °C
Hysteresis	3...15 %
Electrical data	
Operating voltage	10...30 VDC
Residual ripple	≤ 10 % U _{ss}
DC rated operational current	≤ 200 mA
Rated operational current	See derating curve
No-load current	10 mA
Residual current	≤ 0.1 mA
Isolation test voltage	≤ 0.5 kV
Short-circuit protection	no
Voltage drop at I _e	≤ 0.7 V
Wire breakage/Reverse polarity protection	yes / yes (voltage supply)

Functional principle

Inductive sensors detect metal objects contactless and wear-free. For this purpose they use a high-frequency electromagnetic AC field that interacts with the target. The sensors hosting a ferrite core coil generate the AC field through an LC resonant circuit. Special versions are available for ambient temperatures between -60°C and +250°C.

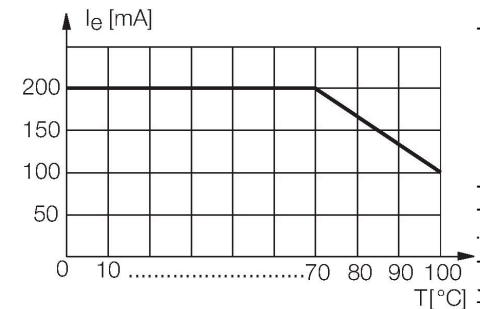

NI4-S12-AP7X/S100 | 11/07/2023 15-10 | technical changes reserved

Technical data

Output function	3-wire, NO contact, PNP
Switching frequency	2 kHz
Mechanical data	
Design	Threaded barrel, M12 x 1
Dimensions	64 mm
Housing material	Plastic, PA12-GF30
Active area material	Plastic, PA12-GF30
End cap	Plastic, EPTR
Max. tightening torque of housing nut	1 Nm
Electrical connection	Cable
Cable quality	Ø 5.2 mm, LifYY-T105, PVC, 2 m
Core cross-section	3 x 0.5 mm ²
Environmental conditions	
Ambient temperature	-25...+100 °C
Vibration resistance	55 Hz (1 mm)
Shock resistance	30 g (11 ms)
Protection class	IP67
MTTF	2283 years acc. to SN 29500 (Ed. 99) 40 °C
Switching state	LED, Yellow

Mounting instructions

Mounting instructions/Description

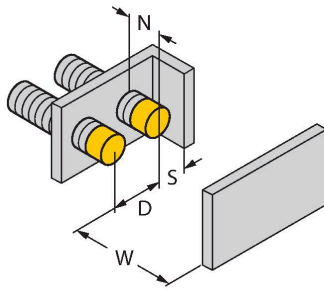

Distance D	3 x B
Distance W	3 x Sn
Distance T	3 x B
Distance S	1.5 x B
Distance G	6 x Sn
Distance N	2 x Sn
Diameter active area B	Ø 12 mm

Accessories

QM-12

6945101

Quick-mount bracket with dead-stop; material: Chrome-plated brass. Male thread M16 × 1. Note: The switching distance of the proximity switches may change when using quick-mount brackets.

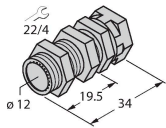

BST-12B

6947212

Mounting clamp for threaded barrel sensors, with dead-stop; material: PA6

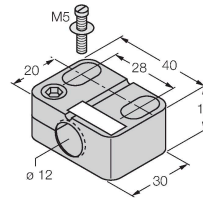

MW-12

6945003

Mounting bracket for threaded barrel sensors; material: Stainless steel A2 1.4301 (AISI 304)

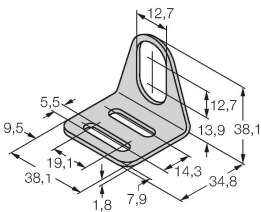

BSS-12

6901321

Mounting clamp for smooth and threaded barrel sensors; material: Polypropylene

