

# BC10-Q14-VP4X2

## Capacitive Sensor

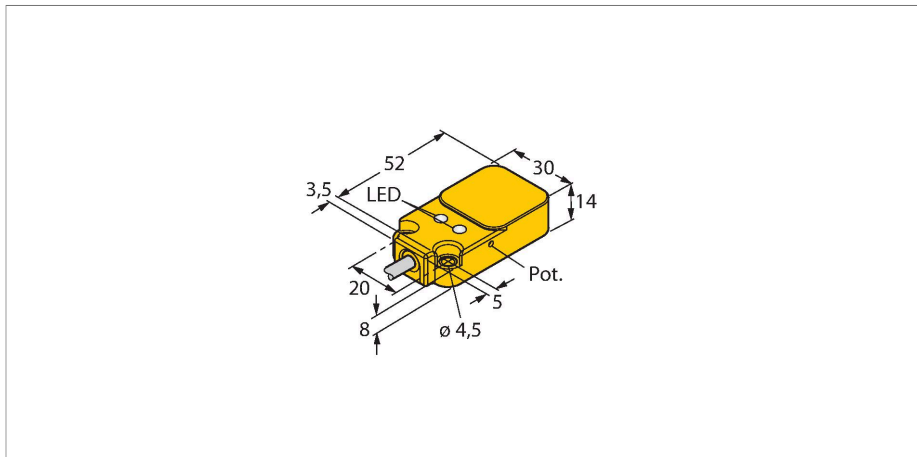

### Features

- Rectangular, height 14mm
- Active face on top
- Plastic, PBT-GF30-V0
- Fine adjustment via potentiometer
- DC 4-wire, 10...65 VDC
- Complementary contact, PNP output
- Cable connection

### Wiring diagram

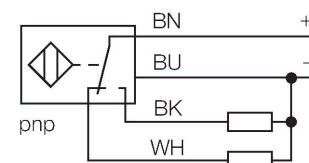

### Functional principle

Capacitive proximity switches are designed for non-contact and wear-free detection of electrically conductive as well as non-conductive metal objects.

### Technical data

Type	BC10-Q14-VP4X2
ID	2530020
Rated switching distance (flush)	10 mm
Rated switching distance (non-flush)	10 mm
Secured operating distance	$\leq (0.72 \times S_n)$
Hysteresis	1...20 %
Temperature drift	Typical 20 %
Repeat accuracy	$\leq 2$ % of full scale
Ambient temperature	-25...+70 °C
<b>Electrical data</b>	
Operating voltage	10...65 VDC
Residual ripple	$\leq 10$ % $U_{ss}$
DC rated operational current	$\leq 200$ mA
No-load current	$\leq 15$ mA
Residual current	$\leq 0.1$ mA
Switching frequency	0.1 kHz
Oscillation frequency	According to EN 60947-5-2, 8.2.6.2 Table 9: 0.1...2.0 MHz
Isolation test voltage	$\leq 0.5$ kV
Output function	4-wire, Complementary contact, PNP
Short-circuit protection	yes / Cyclic
Voltage drop at $I_o$	$\leq 1.8$ V
Wire breakage/Reverse polarity protection	yes / Complete

## Technical data

Tests/approvals	
Approvals	UL
UL registration number	E210608
Mechanical data	
Design	Rectangular, Q14
Dimensions	55.5 x 30 x 14 mm
Housing material	Plastic, PBT-GF30-V0
Active area material	PBT-GF30-V0
Electrical connection	Cable
Cable quality	Ø 5.2 mm, LifYY-11Y, PUR, 2 m
Core cross-section	4 x 0.34 mm <sup>2</sup>
Vibration resistance	55 Hz (1 mm)
Shock resistance	30 g (11 ms)
Protection class	IP67
MTTF	1080 years acc. to SN 29500 (Ed. 99) 40 °C
Power-on indication	LED, Green
Switching state	LED, Yellow
Included in delivery	MH-Q14