

BC20-Q20-VP4X2-H1141

Capacitive Sensor

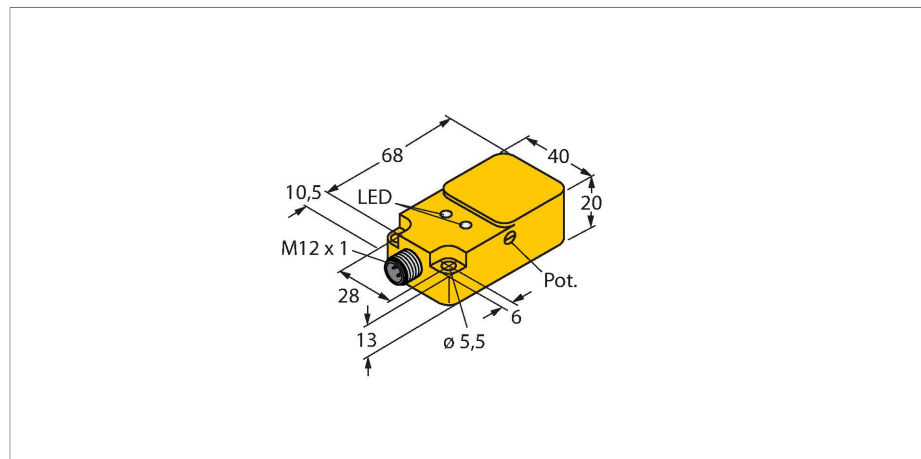

Features

- Rectangular, height 20mm
- Active face on top
- Plastic, PBT-GF30-V0
- Fine adjustment via potentiometer
- DC 4-wire, 10...65 VDC
- Complementary contact, PNP output
- M12 × 1 connector

Wiring diagram

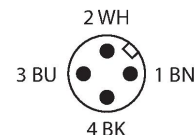
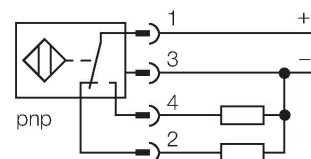

Technical data

Type	BC20-Q20-VP4X2-H1141
ID	2530121
Rated switching distance (flush)	20 mm
Rated switching distance (non-flush)	20 mm
Secured operating distance	≤ (0.72 × Sn)
Hysteresis	1...20 %
Temperature drift	Typical 20 %
Repeat accuracy	≤ 2 % of full scale
Ambient temperature	-25...+70 °C
Electrical data	
Operating voltage	10...65 VDC
Residual ripple	≤ 10 % U _{ss}
DC rated operational current	≤ 200 mA
No-load current	≤ 15 mA
Residual current	≤ 0.1 mA
Switching frequency	0.1 kHz
Oscillation frequency	According to EN 60947-5-2, 8.2.6.2 Table 9: 0.1...2.0 MHz
Isolation test voltage	≤ 0.5 kV
Output function	4-wire, Complementary contact, PNP
Short-circuit protection	yes / Cyclic
Voltage drop at I _o	≤ 1.8 V
Wire breakage/Reverse polarity protection	yes / Complete

Functional principle

Capacitive proximity switches are designed for non-contact and wear-free detection of electrically conductive as well as non-conductive metal objects.

Technical data

Tests/approvals	
Approvals	UL
UL registration number	E210608
Mechanical data	
Design	Rectangular, Q20
Dimensions	68 x 40 x 20 mm
Housing material	Plastic, PBT-GF30-V0
Active area material	PBT-GF30-V0
Electrical connection	Connector, M12 × 1
Vibration resistance	55 Hz (1 mm)
Shock resistance	30 g (11 ms)
Protection class	IP67
MTTF	1080 years acc. to SN 29500 (Ed. 99) 40 °C
Power-on indication	LED, Green
Switching state	LED, Yellow
Included in delivery	Mounting sleeve (MH-Q20), 2 pcs.