

# BI1-EG05-AP6-V1331

## Inductive Sensor

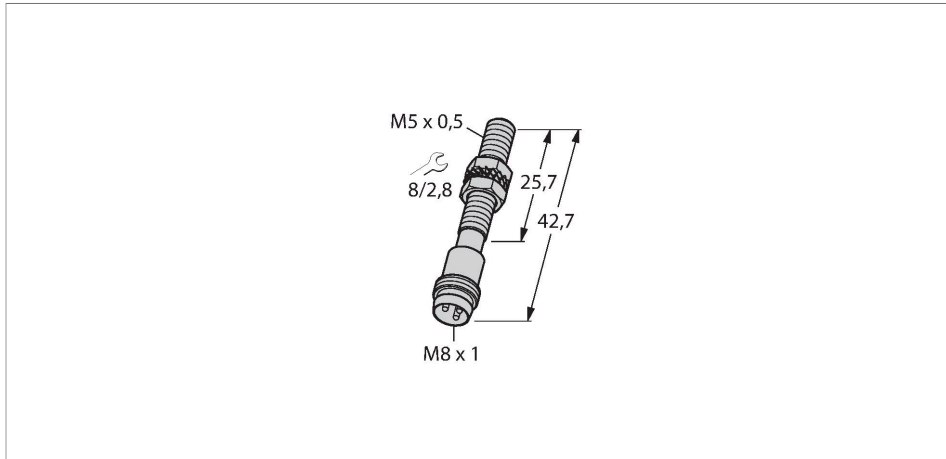

### Features

- Threaded barrel, M5 x 0.5
- Stainless steel, 1.4427 SO
- DC 3-wire, 10...30 VDC
- NO contact, PNP output
- M8 x 1 male connector

### Wiring diagram

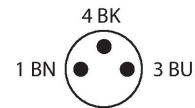
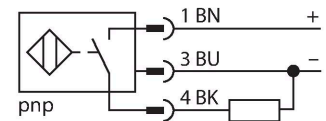

### Technical data

Type	BI1-EG05-AP6-V1331
ID	4609756
<b>General data</b>	
Rated switching distance	1 mm
Mounting conditions	Flush
Secured operating distance	≤ (0.81 × S <sub>n</sub> ) mm
Correction factors	St37 = 1; Al = 0.3; stainless steel = 0.7; Ms = 0.4
Repeat accuracy	≤ 2 % of full scale
Hysteresis	3...15 %
<b>Electrical data</b>	
Operating voltage	10...30 VDC
Residual ripple	≤ 10 % U <sub>ss</sub>
DC rated operational current	≤ 100 mA
No-load current	15 mA
Residual current	≤ 0.1 mA
Isolation test voltage	≤ 0.5 kV
Short-circuit protection	yes / Cyclic
Voltage drop at I <sub>o</sub>	≤ 1.8 V
Wire breakage/Reverse polarity protection	yes / Complete
Output function	3-wire, NO contact, PNP
Switching frequency	3 kHz
<b>Mechanical data</b>	
Design	Threaded barrel, M5 x 0.5

### Functional principle

Inductive sensors detect metal objects contactless and wear-free. For this, they use a high-frequency electromagnetic AC field that interacts with the target. Inductive sensors generate this field via an RLC circuit with a ferrite coil.

## Technical data

Dimensions	42.7 mm
Housing material	Stainless steel, 1.4427 SO
Max. tightening torque of housing nut	5 Nm
Electrical connection	Connector, M8 × 1
<b>Environmental conditions</b>	
Ambient temperature	-25...+70 °C
Vibration resistance	55 Hz (1 mm)
Shock resistance	30 g (11 ms)
Protection class	IP67
MTTF	2283 years acc. to SN 29500 (Ed. 99) 40 °C

## Mounting instructions

### Mounting instructions/Description

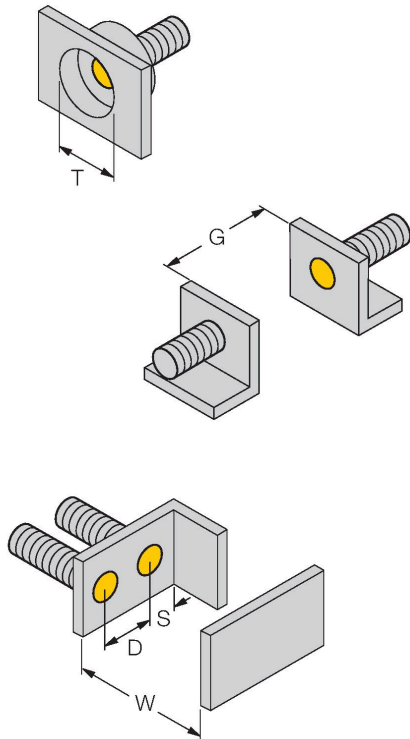

Distance D	2 x B
Distance W	3 x Sn
Distance T	3 x B
Distance S	1.5 x B
Distance G	6 x Sn
Diameter active area B	Ø 5 mm