

NI8-M12-AP6X-0.2-RS4T

Inductive Sensor – With Increased Switching Distance

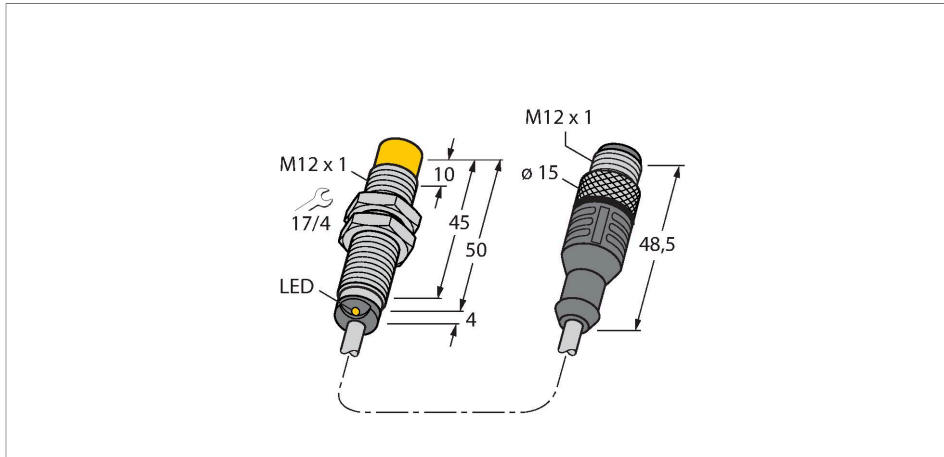

Features

- Threaded barrel, M12 x 1
- Chrome-plated brass
- Large sensing range
- DC 3-wire, 10...30 VDC
- NO contact, PNP output
- Pigtail with male end M12 x 1

Wiring diagram

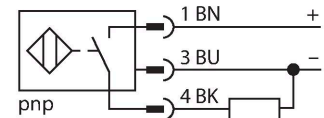

Functional principle

Inductive sensors detect metal objects contactless and wear-free. For this, they use a high-frequency electromagnetic AC field that interacts with the target. Inductive sensors generate this field via an RLC circuit with a ferrite coil.

Technical data

| | |
|---|---|
| Type | NI8-M12-AP6X-0.2-RS4T |
| ID | 46113800 |
| General data | |
| Rated switching distance | 8 mm |
| Mounting conditions | Non-flush |
| Secured operating distance | $\leq (0.81 \times S_n)$ mm |
| Correction factors | St37 = 1; Al = 0.3; stainless steel = 0.7; Ms = 0.4 |
| Repeat accuracy | ≤ 2 % of full scale |
| Temperature drift | $\leq \pm 10$ % |
| Hysteresis | 3...15 % |
| Electrical data | |
| Operating voltage | 10...30 VDC |
| Residual ripple | ≤ 10 % U_{ss} |
| DC rated operational current | ≤ 200 mA |
| No-load current | 15 mA |
| Residual current | ≤ 0.1 mA |
| Isolation test voltage | ≤ 0.5 kV |
| Short-circuit protection | yes / Cyclic |
| Voltage drop at I_o | ≤ 1.8 V |
| Wire breakage/Reverse polarity protection | yes / Complete |
| Output function | 3-wire, NO contact, PNP |
| Switching frequency | 2 kHz |

Technical data

| Mechanical data | |
|---------------------------------------|--|
| Design | Threaded barrel, M12 x 1 |
| Dimensions | 54 mm |
| Housing material | Metal, CuZn, Chrome-plated |
| Active area material | Plastic, PA12-GF30 |
| End cap | Plastic, EPTR |
| Material coupling nut | metal, CuZn, nickel-plated |
| Max. tightening torque of housing nut | 10 Nm |
| Electrical connection | Cable with connector, M12 × 1 |
| Cable quality | Ø 5.2 mm, LifYY, PVC, 0.2 m |
| Core cross-section | 3 x 0.34 mm ² |
| Environmental conditions | |
| Ambient temperature | -25...+70 °C |
| Vibration resistance | 55 Hz (1 mm) |
| Shock resistance | 30 g (11 ms) |
| Protection class | IP67 |
| MTTF | 2283 years acc. to SN 29500 (Ed. 99) 40 °C |
| Switching state | LED, Yellow |

Mounting instructions

Mounting instructions/Description



Distance D 5 x B

Distance W 3 x Sn

Distance T 3 x B

Distance S 6 mm

Distance G 6 x Sn

Distance N 2 x Sn

Diameter active area B \varnothing 12 mm

Accessories

QM-12

6945101

Quick-mount bracket with dead-stop; material: Chrome-plated brass. Male thread M16 x 1. Note: The switching distance of the proximity switches may change when using quick-mount brackets.

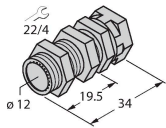

BST-12B

6947212

Mounting clamp for threaded barrel sensors, with dead-stop; material: PA6

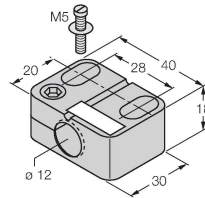

MW-12

6945003

Mounting bracket for threaded barrel sensors; material: Stainless steel A2 1.4301 (AISI 304)

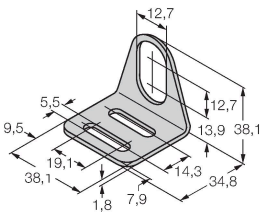

BSS-12

6901321

Mounting clamp for smooth and threaded barrel sensors; material: Polypropylene

