

REMOTE MOUNTING TEMPERATURE SWITCH AND CONTROL



FEATURES

- Single or Dual 15 A Switch Output
- Panel or Surface Mount
- External adjustment via reference dial
- Heat Tracing Models
- Adjustable Ranges Within -130 to 650°F (-90 to 343.3°C)





OVERVIEW

The E55 Series provides rugged, dependable temperature control for many applications. Available in single or dual output versions, with either an epoxy coated enclosure (designed to meet NEMA Type 4X) or skeleton construction, the E55 combines flexibility with compact size. It has been used in diverse applications such as food service appliances, oven control, and heat tracing.

FEATURES

- Single or dual 15 A switch output
- Skeleton or Enclosure construction - designed to meet NEMA Type 4X
- Optional external manual reset
- Compact size
- Copper or stainless steel bulb & capillary

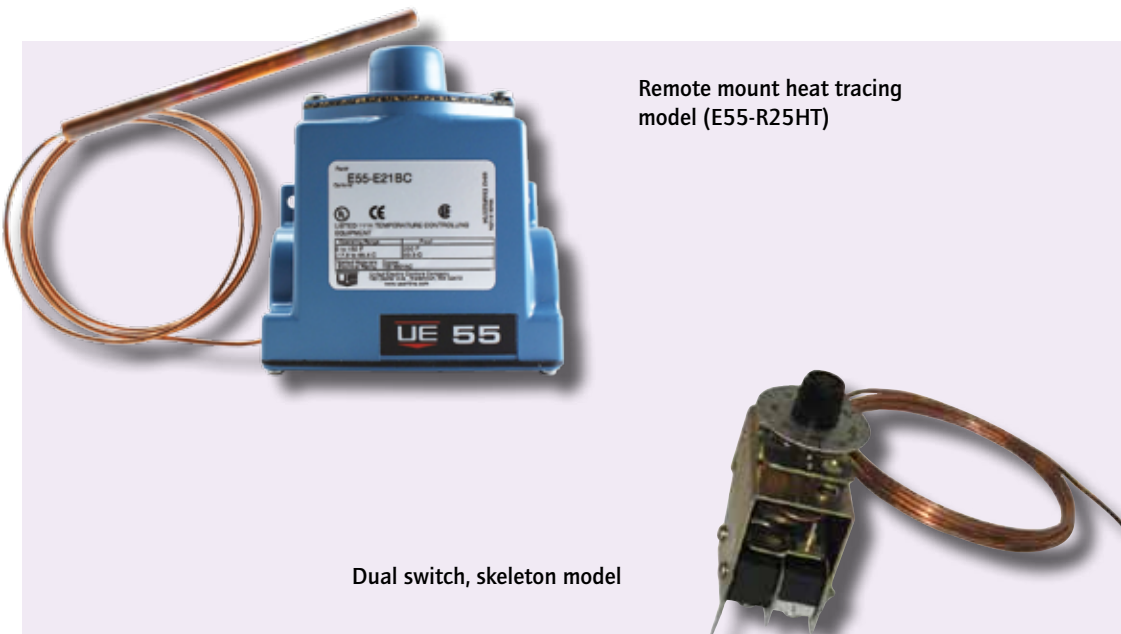

Remote mount heat tracing model (E55-R25HT)

Dual switch, skeleton model

SPECIFICATIONS

STORAGE TEMPERATURE	-65 to 160°F (-54 to 71°C)
AMBIENT TEMPERATURE LIMITS	-40 to 160°F (-40 to 71°C); set point typically shifts less than 1% of range for a 50°F (28°C) ambient temperature change
SET POINT REPEATABILITY	± 1% of adjustable range
SHOCK	Set point repeats after 15 G, 10 millisecond duration
VIBRATION	Set point repeats after 2.5 G, 5-500 Hz
ENCLOSURE CLASSIFICATION	Type E55 & E55A: Designed to meet enclosure type 4X requirements Types E55S & E55AS: Skeleton, open frame construction, not applicable
ENCLOSURE	Die cast aluminum, epoxy powder coated with stainless steel, gasketed adjustment cover (E55 and E55A)
SWITCH OUTPUT	One or two SPDT; dual switch may be separated up to 100% of range; switches may be wired "normally open" or "normally closed"
ELECTRICAL RATING	15 A 125/250/480 VAC resistive; 22 A 480 VAC for E55-R25HT and E55-L24HT heat trace models. Electrical switches have limited DC capabilities. Consult factory for additional information
ELECTRICAL CONNECTION	1/2" NPT (female) (E55 and E55A)
WEIGHT	Types E55S, E55AS (skeleton): approximately 12 oz.; Types E55, E55A: approximately 1 lb.
BULB AND CAPILLARY	Models E20BC - E23BC: 6 feet copper; Models E20BS - E23BS: 6 feet stainless steel Model R25HT-101: 10 feet stainless steel Model L24HT: stainless steel, Local sensor, no capillary, for ambient sensing
TEMPERATURE FILL	Non-toxic oil
TEMPERATURE DEADBAND	Typically 1% of range under laboratory conditions (70°F circulating bath at rate of 1/2°F per minute change)

APPROVALS



UNITED STATES AND CANADA

E55(A) Models **UL Listed, CSA Certified**

UL 873, file # E10667; C22.2 no. 24, file # LR7814

E55(A)S Models **UL Recognized, CSA Certified**

UL 873, file # E10667; C22.2 no. 24, file # LR7814

EUROPE

Low Voltage Directive (LVD) (73/23/EC & 93/68/EEC) **UEC compliant to LVD**

Products rated lower than 50 VAC and 75 VDC are outside of the scope of the LVD



MODEL CHART

Model	Adjustable Set Point Range		Max. Temp.		Dial Div.		Bulb Size
	°F	°C	°F	°C	°F	°C	OD x Length (inches)
Copper bulb & capillary							
E20BC	-130 to 120	-90 to 48.9	170	76.7	10	5	3/8 x 4-3/8
E21BC	0 to 150	-17.8 to 65.6	200	93.3	5	5	3/8 x 6-7/8
E22BC	50 to 300	10 to 148.9	350	176.7	10	5	3/8 x 4-3/8
E23BC	150 to 650	65.6 to 343.3	700	371.1	25	10	3/8 x 3-5/8
Stainless steel bulb and capillary							
E20BS [‡]	-130 to 120	-90 to 48.9	170	76.7	10	5	3/8 x 4-3/8
E21BS	0 to 150	-17.8 to 65.6	200	93.3	5	5	3/8 x 6-7/8
E22BS	50 to 300	10 to 148.9	350	176.7	10	5	3/8 x 4-3/8
E23BS	150 to 650	65.6 to 343.3	700	371.1	25	10	3/8 x 3-5/8
R25HT ^{‡‡}	25 to 325	-3.9 to 162.8	600	315.6	10	-	1/4 x 7-3/16
L24HT ^{‡‡}	15 to 140	-9.4 to 60	190	87.8	5	-	3/8 x 7

[‡] Not available with Type E55AS

^{‡‡} Not available with Types E55A, E55S, E55AS

HOW TO ORDER

BUILDING A PART NUMBER

Select a **Type**

Refer to the "Type" section below.

Determine type number based on switch output, enclosure, adjustment and reference.

Fill in the type portion of your part number with the corresponding number.

Select a **Model**

Refer to the "Model Charts".

Determine model based on adjustable range, and capillary material.

Fill in the model portion of your part number with the corresponding number.

Select an **Option**

Refer to the "Options" section.

Determine option number based on switch output, optional materials or other product enhancements.

Fill in the option portion of your part number with the corresponding number.

Leave "option" portion blank if no options are needed. *FOR MULTIPLE OPTIONS:* Call United Electric Controls.

TYPE

E55	Bulb & capillary; one SPDT output; Epoxy coated enclosure; external adjustment with reference dial, tamper-resistant cover
E55A	Bulb & capillary; two SPDT outputs; Epoxy coated enclosure; external adjustment with reference dial, tamper-resistant cover
E55S	Bulb & capillary; one SPDT output; skeleton construction; external adjustment with reference dial
E55AS	Bulb & capillary; two SPDT outputs; skeleton construction; external adjustment with reference dial

SWITCH OPTIONS*

0500	Close deadband, 5 A 125/250 VAC resistive. NOT AVAILABLE ON MODELS R25HT, L24HT
1530	External manual reset, 15 A 125/250/480 VAC resistive; reset on increasing temperature. NOT AVAILABLE ON TYPES E55S, E55AS, & MODELS R25HT, L24HT
2000	20 A 125/250 VAC resistive. NOT AVAILABLE ON MODELS R25HT, L24HT

GENERAL

M020	Pilot light. AVAILABLE HEAT TRACE MODELS R25HT, L24HT ONLY
M201	Factory set one switch; specify increasing or decreasing temperature and set point. NOT AVAILABLE ON TYPES E55A, E55AS
M202	Factory set two switches; specify increasing or decreasing temperature and set point. NOT AVAILABLE ON TYPES E55, E55S
M270	Calibrated dial in Celsius. NOT AVAILABLE ON HEAT TRACE MODELS R25HT, L24HT
M444	Paper ID tag. NOT AVAILABLE ON HEAT TRACE MODELS R25HT, L24HT
M446	Stainless steel ID tag & wire attachment

UNION CONNECTORS**

(Not available on model L24HT or R25HT)

Option	Replacement Number	Description
<u>Brass</u>		
W027	SD6213-27	1/2" NPT w/ 3/4" bushing
W045	SD6213-45	3/4" NPT
W051	SD6213-51	1/2" NPT
<u>304 Stainless Steel</u>		
W028	SD6213-28	1/2" NPT w/ 3/4" bushing
W046	SD6213-46	3/4" NPT
W050	SD6213-50	1/2" NPT

THERMOWELLS**

For all bulb & capillary switches, all 1/2" NPT Internal (Not available on models R25HT, L24HT)

<u>Brass</u>		
W075	SD6225-75	1/2" NPT with 3/4" NPT bushing adapter, 4" BT
W191	SD6225-191	1/2" NPT, 4" BT
W118	SD6225-118	1/2" NPT with 3/4" NPT bushing adapter, 7" BT
W192	SD6225-192	1/2" NPT, 7" BT
<u>316 Stainless Steel</u>		
W076	SD6225-76	3/4" NPT, 4.5" BT
W193	SD6225-193	1/2" NPT, 4.5" BT
W119	SD6225-119	3/4" NPT, 7.5" BT
W177	SD6225-177	1/2" NPT, 7.5" BT

OPTIONAL LENGTHS:

Optional capillary length to 50' available in copper or 304 st./st. Armor or Teflon® capillary protection available to lengths less than or equal to capillary length. Consult UE for additional information.

Consult UE regarding repeatability and ambient effects on capillary lengths over 30'.

* All switch options have limited DC capabilities. Consult factory for details.

** Dimensional drawings for union connector and thermowells may be found at www.ueonline.com



DIMENSIONAL DRAWINGS

(Dimensional drawings for all models may be found at www.ueonline.com)

Types E55 / E55A

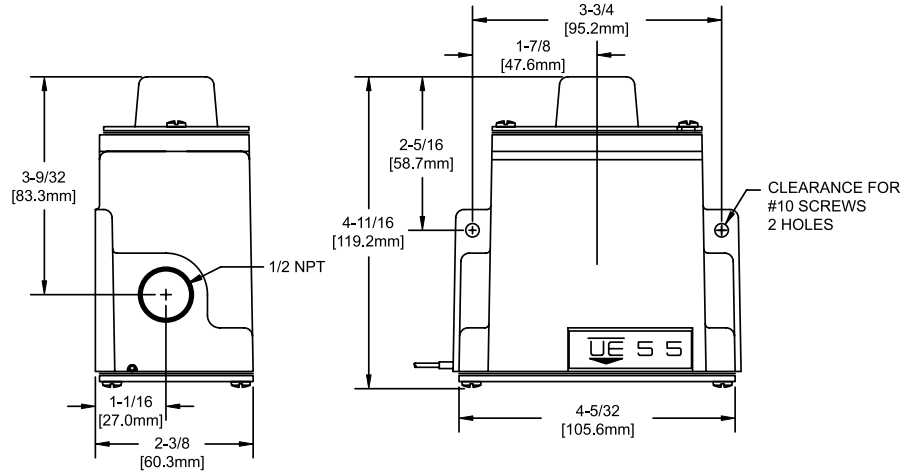

Type E55 Heat Tracing Models

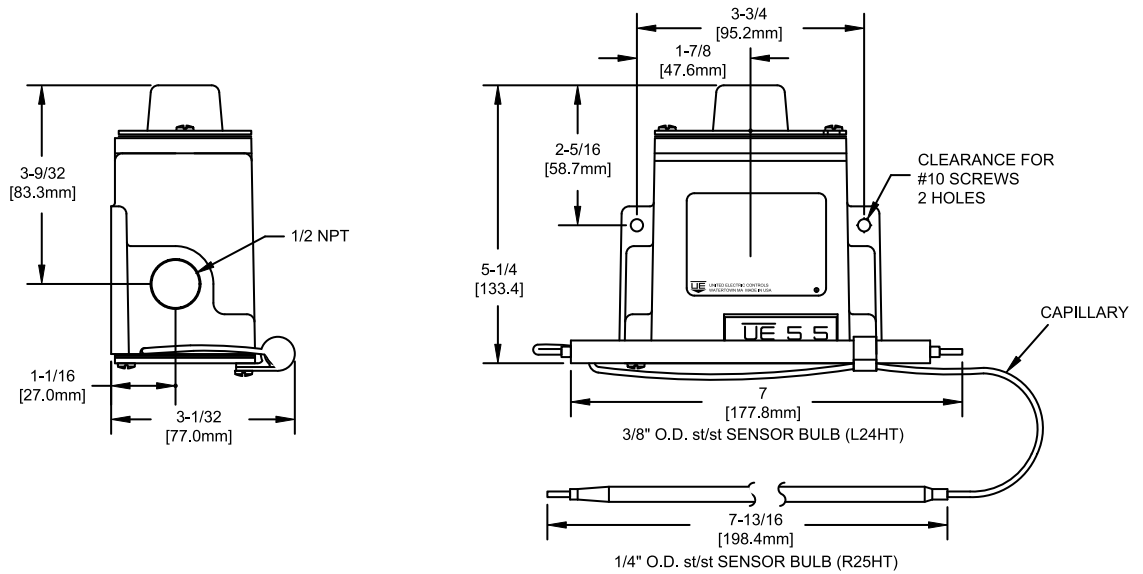

Type E55AS

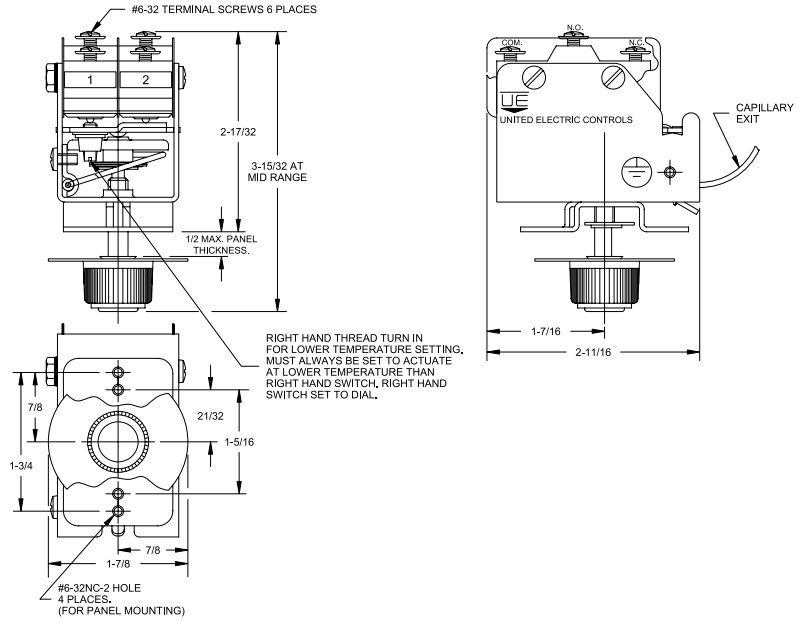

Type E55S

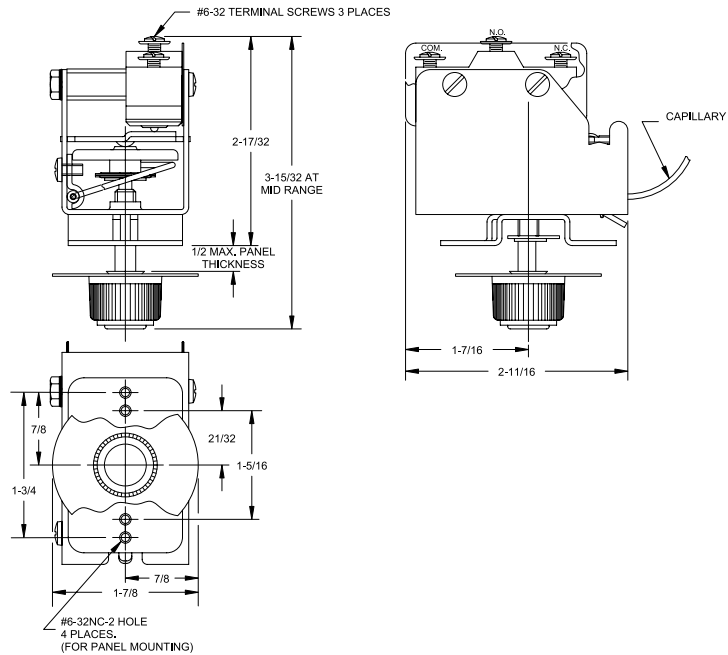

RECOMMENDED PRACTICES AND WARNINGS

United Electric Controls Company recommends careful consideration of the following factors when specifying and installing UE pressure and temperature units. Before installing a unit, the Installation and Maintenance instructions provided with unit must be read and understood.

- To avoid damaging unit, proof pressure and maximum temperature limits stated in literature and on nameplates must never be exceeded, even by surges in the system. Operation of the unit up to maximum pressure or temperature is acceptable on a limited basis (e.g., start-up, testing) but continuous operation must be restricted to the designated adjustable range. Excessive cycling at maximum pressure or temperature limits could reduce sensor life.
- A back-up unit is necessary for applications where damage to a primary unit could endanger life, limb or property. A high or low limit switch is necessary for applications where a dangerous runaway condition could result.
- The adjustable range must be selected so that incorrect, inadvertent or malicious setting at any range point cannot result in an unsafe system condition.
- Install unit where shock, vibration and ambient temperature fluctuations will not damage unit or affect operation. When applicable, orient unit so that moisture does not enter the enclosure via the electrical connection. When appropriate, this entry point should be sealed to prevent moisture entry.
- Unit must not be altered or modified after shipment. Consult UE if modification is necessary.
- Monitor operation to observe warning signs of possible damage to unit, such as drift in set point or faulty display. Check unit immediately.
- Preventative maintenance and periodic testing is necessary for critical applications where damage could endanger property or personnel.
- Electrical ratings stated in literature and on nameplate must not be exceeded. Overload on a switch can cause damage, even on the first cycle. Wire unit according to local and national electrical codes, using wire size recommended in installation sheet.
- Do not mount unit in ambient temp. exceeding published limits.

LIMITED WARRANTY

Seller warrants that the product hereby purchased is, upon delivery, free from defects in material and workmanship and that any such product which is found to be defective in such workmanship or material will be repaired or replaced by Seller (Ex-works, Factory, Watertown, Massachusetts. INCOTERMS); provided, however, that this warranty applies only to equipment found to be so defective within a period of 24 months from the date of manufacture by the Seller. Seller shall not be obligated under this warranty for alleged defects which examination discloses are due to tampering, misuse, neglect, improper storage, and in any case where products are disassembled by anyone other than authorized Seller's representatives. EXCEPT FOR THE LIMITED WARRANTY OF REPAIR AND REPLACEMENT STATED ABOVE, SELLER DISCLAIMS ALL WARRANTIES WHATSOEVER WITH RESPECT TO THE PRODUCT, INCLUDING ALL IMPLIED WARRANTIES OF MERCHANTABILITY OR FITNESS FOR ANY PARTICULAR PURPOSE.

LIMITATION OF SELLER'S LIABILITY

SELLER'S LIABILITY TO BUYER FOR ANY LOSS OR CLAIM, INCLUDING LIABILITY INCURRED IN CONNECTION WITH (I) BREACH OF ANY WARRANTY WHATSOEVER, EXPRESSED OR IMPLIED, (II) A BREACH OF CONTRACT, (III) A NEGLIGENT ACT OR ACTS (OR NEGLIGENT FAILURE TO ACT) COMMITTED BY SELLER, OR (IV) AN ACT FOR WHICH STRICT LIABILITY WILL BE INPUTTED TO SELLER, IS LIMITED TO THE "LIMITED WARRANTY" OF REPAIR AND/OR REPLACEMENT AS SO STATED IN OUR WARRANTY OF PRODUCT. IN NO EVENT SHALL THE SELLER BE LIABLE FOR ANY SPECIAL, INDIRECT, CONSEQUENTIAL OR OTHER DAMAGES OF A LIKE GENERAL NATURE, INCLUDING, WITHOUT LIMITATION, LOSS OF PROFITS OR PRODUCTION, OR LOSS OR EXPENSES OF ANY NATURE INCURRED BY

U.S. SALES OFFICES

United Electric Controls
31 Old Stage Road
Hampton Falls, NH 03844
Phone: 617-899-1132
email: northeastsales@ueonline.com

United Electric Controls
28 N. Wise Ave.
Freeport, IL 61032
Phone: 815-341-2588
email: midwestsales@ueonline.com

United Electric Controls
1022 Vineyard Drive
Conyers, GA 30013
Phone: 770-335-9802
email: southeastsales@ueonline.com

United Electric Controls
5829 Grazing Court
Mason, OH 45040
Phone: 513-535-5486
email: midatlanticsales@ueonline.com

United Electric Controls
102 Salazar Court
Clayton, CA 94517
Phone: 925-408-5997
email: westcoastsales@ueonline.com

United Electric Controls
27 Summit Terrace
Sparta, NJ 07871
Phone: 973-271-2550
email: easternsales@ueonline.com

United Electric Controls
4306 Whickham Drive
Fulshear, TX 77441
Phone: 832-457-6138
email: southwestsales@ueonline.com

CANADA

EASTERN
68 Mosley Crescent
Brampton, Ontario
Canada L6Y 5C8
Phone: 905-455-5131
FAX: 905-455-5131

INTERNATIONAL OFFICES

CHINA
United Electric Controls, *Shanghai Office*
Room 1011, 10th Flr,
Huai Hai Zhonghua Building
No. 885, Renmin Road, Luwan District
Shanghai 200010, P.R. China
Phone: +8621-6255 8059
email: chinasales@ueonline.com

United Electric Controls, *Beijing Office*
Room 1006, Jainhao International Bldg.
Block D, No. 116
Zizhuyuanlu, Haidian District
Beijing, China 100089
Phone: +86-10-5893-0518
email: beijingsales@ueonline.com

EASTERN EUROPE & SCANDINAVIA
United Electric Controls
05-806 Komorow
Kujawska 5, Poland
Phone: +48 22 499 4804
email: easterneuropesales@ueonline.com

GERMANY
United Electric Controls
An Der Zentlinde 21
D-64711 Erbach, Germany
Phone: 496-062-7400
email: europesales@ueonline.com

INDIA
United Electric Controls
House no. 7, Kamalkunj Society
Nizampura,
Baraoda (Gujarat), India
Phone: +91 (-265) -2788654
email: indiasales@ueonline.com

ASIA-PACIFIC
United Electric Controls, Far East
No. 1-2-2, 2nd Floor
Jalan 4/101C
Cheras Business Centre
Batu 5, Jalan Cheras
56100 Kuala Lumpur, Malaysia
Phone: 603-9133-4122
email: fareastsales@ueonline.com

MEXICO
United Electric Controls
Zacatecas # 206, Suite 20
Col Guadalupe CP 89120
Tampico, Tamaulipas Mexico
Phone: 833-217-5201
email: latinamericasales@ueonline.com

RUSSIA
United Electric Controls, Moscow
Elinskaya str., 15-140
Moscow, 121552, Russia
Phone: +7 (495) 792-88-06
email: russiansales@ueonline.com



UNITED ELECTRIC
CONTROLS

180 Dexter Avenue, P.O. Box 9143
Watertown, MA 02471-9143 USA
Telephone: 617 926-1000 Fax: 617 926-2568
<http://www.ueonline.com>

Be sure to visit www.ueonline.com for the latest information.

CP04101000